

# Communications Log

## Exchanges with Jen Han Eredyon

Updated: 20-AUG-2025

### Dan:

I thought, just in case Jen Han was able to, or had permission to share some advanced knowledge about crystals, that maybe I should put together a few questions.

I don't have an expectation to have these all answered, but what a gift that would be to have further understanding from such an evolved being that truly understands the advanced sciences at its core!

I know I went a bit overboard with questions here, Jen Han can respond to those which he feels relevant and appropriate for us Terrans to understand.

So, If I was able to ask Jen Han questions about crystals, these are a few questions that come to mind...

**Dan (Comment):** Much gratitude to Elena, Jen Han and Thor Han Eredyon for the following insights on crystal technology that follows.

## Jen Han Eredyon Session – 04-22-2022

**First communications from Jen Han Eredyon received via Elena on April 22, 2022**

### Regarding use of the Crystal

**Dan (via Elena):** If one forms a thought in their mind to project or resonate into a crystal, what is the connection between this communication of thought and breath? Is the exhalation of breath coupled with thought stronger when rapidly exhaling the breath in a pulse to resonate within the crystal?  
*(Dr Marcel Vogel discovered and measured this in his communicating with plants)*

**Jen Han:** Breath carries memories and thoughts, it also carries the energy of a being, not only the encoding of its vehicle DNA but as well the encoding of the soul. When you project breath, you also project by superimposing, a parcel of the soul/being. Hence a fragment of one's consciousness. The energy force that is a living manifestation of Source is being impregnated inside the crystal but beware, the crystal must be empty. This means: no residual emotional imprint, parasiting or charge. The crystal must be pure and clear from any form of energy, or consciousness even. I wouldn't say that at this stage, the crystal is really "empty", because it carries its frequency imprint, but I mean empty from anything that is not the original frequency signature of the crystal. In order to perform this action: embedding a fractal of your consciousness in a dynamic projection, into the crystal, the receptacle must be pristine pure. There are methods of purification I can tell about, the best is to run the crystal through a sound scan. You need instruments that create a high frequency sound, or trained persons can clear a crystal with their own consciousness. These individuals have reached a clear state of mind.

**Dan (Comment):** This is so important about the breath, that it substantiates that the information is indeed encoded with the breath, and the importance of first clearing the crystal of previously imprinted information before use. The two methods Dr Vogel used to clear the crystal was first with the pulsed breath with the intention to clear. The other method was to use a magnetic bulk eraser, the type used to erase the old VHS video tapes which puts out a strong 60 Hz magnetic field to erase the magnetic domain alignments. The crystal must be cleared before use is very important.

**Elena:** Does a tuning fork 4096 Hz do the job?

**Jen Han:** Not enough. It will clear the energies but not the emotional imprints.

**Elena:** What do you call the emotional imprints and how to clear them?

**Jen Han:** I have a device that does that but I cannot show it to you, I am sorry.

**Elena:** I understand, it is OK. So anything else you can say about the breath? Its speed, rhythm?

**Jen Han:** short precise, surgical, powerful breaths are better than a long one. In a long one, the energy/intention gets absorbed by the Ether. In short quick breaths, the energy/intention keeps intact and doesn't lose intensity. I recommend short quick breaths, think about "precise surgical". Intention is like a needle: sharp and targeted very precisely to be able to penetrate matter.

**Dan (Comment):** This is exactly what Dr Vogel discovered and was able to measure this on a script chart recorder with plant communication. He studied Pranayama yogic breathing techniques and found exactly as Jen Han describes, that a short precise powerful breath had the greatest effect.

**Dan (via Elena):** The higher the dimensional frequency, it appears to have a greater connection to the common fundamental core of the collective mind of all minds of humanity share on planet Terra. Since the crystal may act as a bridge to couple the energies of mind, would it be a true statement that, a thought or visualization, aligned with the love of your heart, projected into the crystal by pulsing the breath with positive intention, acts to collectively affect in a benevolent way, the collective minds of many on Terra, to help assist in co-creatively manifesting that thought or visualization? *(the opposite of a black magic spell)*

**Jen Han:** There are several elements to be answered in this question. Firstly, a quartz crystal, or any mineral is in resonance with the planetary matrix it is born from. When you bring your frequency-thought on the same resonance as the crystal, or any type of mineral, you attune also to its planetary matrix.

**Dan (Comment):** So the crystals produced on Terra, like the DNA in our physical bodies made of this planet, are in resonance with Terra's planetary matrix and therefore would effectively transfer the energies of mind to the collective mind of our planetary matrix. So the Martians will be only effective resonating with their planetary matrix of Mars etc.

**Elena:** Stop! How to do that? How to attune to the frequency of the mineral and how do you know you're on it, and how does it work?

**Jen Han:** It works by mineral resonance. Your blood. It is easier when you are in a body envelop that is from same planetary matrix you desire to work upon. Otherwise you need to do an effort or require technology. But in the case of your friend, and yourself, you can do this easily because your envelopes are from the same planetary matrix as the crystals you have available to work with. You take the mineral/ crystal in your two hands. It creates a current. Best is to have one in each hand but it works also with your two hands on one single crystal. Your hands must not touch. The current will work naturally. It is even better if you are in direct connection with the soil of the planetary matrix. You intend to make one with the planetary matrix. The crystal is the connector if you will. Quartz is best. Always works. Quartz is found throughout the whole universe. It is a fundamental component. You know you are in resonance when you feel it. It's like a shiver in your whole body, from your heart center. You may even hear the crystal singing the frequency of the planetary matrix.

**Dan (Comment):** Yes, you don't want to short your polarity charge out by touching your hands or feet together. Electrically connecting to the earth (Terra) is an important concept to conduct these energies into the earth. Especially if you can find a nodal point on the Terra earth grid.

In doing an online visualization exercise with a crystal in front of a computer screen might be enhanced using a ground wire connection from an electrical outlet that you have electrical connection with to conduit your body energies into the earth. I personally have this at my computer station so that I stay grounded and will have to try that next time!

**Elena:** Planetary matrix, is it the same as planet?

**Jen Han:** Yes, that is how I call it. Planetary matrix is more accurate.

**Elena:** So I can say: Oh I am going to the planetary matrix Mars?

**Jen Han:** (laughs) No! You say Planet Mars.

**Elena:** You lost me.

**Jen Han:** "Planetary matrix" is a term used when we mention the conscious, living organic aspect of a planet. "Planet" is a term used only for the location.

**Dan (via Elena):** Any suggestions or techniques to optimize the use of a crystal in the amplification of co-creatively transforming Terra for the most benevolent outcome for all beings? Also for individual healing of self or others?

**Jen Han:** This will also answer the previous question: Love. The frequency of love is the connecting pulse between all living things in the universe. Even through dimensional planes. Love is the universal bridge. It can bridge anything, I mean a-ny-thing, love is the tool. So when you intend love into a crystal, you activate its transcending capacity. When on the top of this action you embed a target by visualization, it bridges you to it easily. Love is a secure channel, because of the high frequency. It prevents dissonance. The target can be: a visualization inside the crystal of a place or a person, you can

also embed a story by moving images or/and vocalization of the story, and you can either, also, embed just a sound: the name of a person or of a place. The more you superimpose layers, the better it is going to work. Repeat for the geometrical resonance. It will force the pattern into the holographic matrix.

**Dan (Comment):** This is very much what an ET being shared with me in 1977 regarding love as the vehicle connecting the multiple densities or frequency geometries in our evolution. This is also why Dr Vogel stressed the importance of love when working with the crystals. For the purpose of ether group or individual visualization exercises in order to seed a positive timeline into the holographic planetary matrix, it is the love in our heart that we have for our fellow humans and our beautiful planet Terra that allows that reality to transcend through the dimensional planes and into manifestation.

Although the second part of my question regarding techniques using the crystal for healing self or others wasn't addressed directly, the same no doubt would apply in healing ourselves or someone else as we resonate with the individual holographic matrix in healing. Love heals.

**Elena:** Thank you! Here is another question:

**Dan (via Elena):** Regarding the Crystal Geometry. Do the energies of mind have a geometric quality?

**Jen Han:** Of course! Everything in the created universe is constructed on a geometrical holographic structure. "The energies of mind": I like that it is worded as such, because there is a difference between this and the electrical brainwaves. The energies of the mind are fractals of consciousness "solidified", in a way, or shall I say, that have taken form as a geometrical manifestation. A thought creates an electrical projection. An energy-thought reshapes the holographic geometrical formula of reality. It rearranges the micro-connections linking the fractal elements. Thought can reshape the holographic grid of reality because thoughts are complex geometrical patterns. The crystal will bridge the new pattern to the existing ones, and if the impulse is strong enough, the new pattern will force themselves onto the old and the old will morph into the new.

**Dan (Comment):** So perfectly described! And so it shall be, that with the power of love, the old will morph into the new.

**Dan (via Elena):** Is this the common fundamental geometrical resonance that allows for telepathy between all species of beings as a universal language? Is this similar to a geometrical resonance within our DNA?

**Jen Han:** Great question! That is the best part in planetary engineering! Creating the morphic grid!

**Elena:** The morphic grid?...

**Jen Han:** Listen, right: imagine a mycelium veil wrapping around a planet, it interconnects everything because it carries information, constantly, simultaneously and towards all points on the web. Well, a morphic grid is a medium that does exactly the same thing. It is sentient, but not as you can comprehend it. It is conscious should I say. When you plug into it, you are in connection with every living thing on the planetary matrix, simultaneously. It is a non-organic consciousness constructed with frequency patterns in the shape of repetitive fractal geometry. There is one single mathematical formula for the whole of it.

**Dan (Comment):** This planetary web matrix is what each mind is a fractal of and each fractal mind acts as a conduit to affect the larger collective mind of the planet which it is a fractal of. Similar I imagine, as in a hologram, if any fractal part of the hologram changes, that change is reflected in every part of the hologram. Being that the planetary morphic grid has a collective mind and that it has a holographic nature.

**Elena:** And when you are in space?

**Jen Han:** You can connect with all living beings of a planetary matrix only when you are in it. It still works when you are in space if the body you inhabit belongs to this planetary matrix. Then, wherever you are in the universe, even on other dimensional planes, you can attune to the morphic grid of the planetary matrix that is in resonance with your body. If I come to my brother's ship, here on orbit of your planet, I will still be able to attune to Erra, my planetary matrix. It is quantum resonance as you name it on Terra. Because of my DNA, you understand? The geometrical encoding of the blood I carry. It is a frequency match to the planetary morphic grid of my world. So the connection is never lost. Yes, it can also be called a geometrical resonance.

**Dan (Comment):** Geometrical resonance appears to be the universal language of the universe.

**Dan (via Elena):** Is what we term "Love" the fundamental structure of this geometrical matrix at its core in the higher dimensions?

**Jen Han:** It is more complex than this, but on the core principle yes.

**Elena:** Can you develop please?

**Jen Han:** Love is not only a frequency. Your people will learn that frequency is a holographic geometry. There are three types of holographic geometry: atomic, energetic and photonic. These three arrangements create each, in their domain, a hologrammatic structure. All three generate a specific frequency that will resonate either through matter, energy or light. The reverse process is also active: when you generate a frequency, it creates a geometric pattern that imprints the ether. The geometrical frequency patterns that you just created alter -or create- a holographic structure of matter, energy or light. Now you need a bridge from ether to matter, energy or light, and can be technology or crystals. Crystals exist in different densities at the same time. They are natural bridges.

**Dan (Comment):** Bridging the etheric energies emanated from mind into the manifestation of matter through the use of a crystal as a bridge is an important concept.

**Dan (via Elena):** It would appear that negative thoughts of evil do not have the resonance to pass through the higher dimensions, as their geometries are a distortion and do not align with the fundamental of the matrix. *(could be the reason why some crystals shatter when misused)*

**Jen Han:** Dissonance cannot attune with an ordered state of geometrical resonance.

**Dan (Comment):** This may also explain the formations captured at the moment of freezing in water (Dr Emoto's work) of the energies of love, gratitude, etc. are able to form in the hexagonal/tetrahedral matrix of water, whereas dissonant energies are unable to.

**Dan (via Elena):** Is this why the similar tetrahedral/hexagon geometry of water responds in structuring in alignment with thoughts of love?

**Jen Han:** Water... it is worth a great speech. Water is one of the fundamental elements of the universe. It is found in a natural state in the cosmos, as ice. We call it star water. Water has a tetrahedral holographic structure. It is a very easy one to create, but the star water is the most wonderful because it is in pure, in perfect resonance with the universe and Source, because directly created by Source. Water, by its natural core structure, is a universal connecting medium. Love is of a more complex holographic structure, but from the same fractal core pattern -fractal formula- as water. Crystal is a derivative geometrical pattern from water and love, but built on the same core formula. This is why all interface naturally.

**Dan (Comment):** This same fundamental holographic core pattern from source which shares this fractal formula with both the elements of water and quartz crystal is what was validated in the laboratory with Dr Vogel in that the structure of the geometry of the molecular angles of these elements are multiples or you could say are angular fractals of each other. Quartz is 52 degrees and water is 26 and 104.5 degrees (half and double 52 degrees)

**Dan (via Elena):** Since the higher dimensions are responsible for forming the lower dimensions, and not visa versa. The ability of the crystal to "amplify" thought appears to be based on its ability to couple to the higher dimensions and thus have an amplifying effect into the lower dimensions that physically manifest into the 3D world.

**Jen Han:** As I said earlier; a crystal is a bridge because it exists in all dimensions at a time.

**Dan (Comment):** Again, an important concept to bridge the dimensions with a crystal.

**Dan (via Elena):** The nature of crystals, especially clear quartz, being physically resonant on many dimensions simultaneously. Is this due to the tetrahedral geometry of its lattice structure being infinitely fractal and this tetrahedral lattice structure being a fundamental structure of the matrix?

**Jen Han:** The core holographic structure of quartz, the purest material in the universe, is as I said based on the same core fractal formula than water, and both are interdimensional bridges. Tetrahedral geometry is one of the main frequency keys used to build worlds and life-forms. Tetrahedral fractal geometry is the secret of the universe.

**Dan (Comment):** Indeed, as some researchers on Terra have discovered, that the entire periodic table of elements are based on a tetrahedral structure to form all of the elements in nature.

**Dan (via Elena):** In the quartz crystal hexagonal structure, the point of balance in the middle between the negative and positive triads (the polarity opposites) that create the crystals hexagonal form, is this center point the dimensional gate to all dimensions?

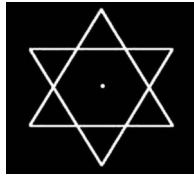

**Jen Han:** The answer is in the geometrical ratio. I need to ask if I can answer that, because this topic is part of the list of things not to mention. You know, the Prime Directive...

**Elena:** I know too well, Jen Han...

**Jen Han:** My brother says I can answer this. It will just be recorded and archived that I passed on to you this information.

**Elena:** You won't be in trouble?

**Jen Han:** No, I won't. Crystals have their own fractal geometry. If they are in their natural original shape they have it active naturally. If they are cut roughly they lose it, but if cut following the lattice structure they keep it, and can even be enhanced considerably that way. Thor Han tells me that you know what type of crystals correspond to what I say.

**Elena:** The Vogel cut crystals?

**Thor Han:** Yes.

**Dan (Comment):** The energy in the crystal vortexes along the C-axis which is the growth axis that forms the crystal to align with the apex or tip of the crystals structure. A properly cut Vogel crystal is formed so that both tips are in perfect alignment with this C-axis or growth axis. This is why Dr Vogel was given in a dream the image of the tree of life as a di-pyramidal form in order to more effectively cohere the energies of mind in a laser like manner. Greater coherence provides greater degree of clarity for manifestation. With one end being female at 52 degrees (the natural angle of quartz) and the other male or projecting end being more of an acute angle.

Regarding the central point between the countless fractal positive and negative charge triads within the crystal lattice structure that forms the overall hexagonal shape of the crystal being a dimensional gate.



Ancient occult writings have described the web as being hexagonal in form. Whereas the male and female balance of the two triads that make up the 6 points of the hexagonal pattern have a 7<sup>th</sup> point in the center which they attribute to “spirit” which emanates outwardly to create the 6 points. Pythagoras called the 6 pointed star with a dot in the center the “star of creation”. This is why I ask about the center of the charge triads being the dimensional gate which appears to vortex in the center.

**Jen Han:** Well: it works by finding the phase-conjugation node inside the crystal, by projecting inwards the geometrical shapes of the two opposite points, like a mirror. There, is the vortex singularity of the crystal. Focus your thought and energy just there, and you may project your consciousness to anywhere you wish in this universe, and the other universes. To other densities, other dimensions. Anything is accessible in space, dimension and time. This is great power, Elena. It is a very important information. I am honored to be allowed to share this with you.

**Elena:** Can my friend share it publicly?

(silence)

**Jen Han:** I am not taking this responsibility.

**Thor Han:** I have it confirmed that Dan can use this knowledge.

**Dan (Comment):** Thank you Thor Han, I believe I am grasping a basic, probably more intuitive, understanding that this phase-conjugation node in the center of the triads and is what we are both describing. I am honored that you are sharing this with me.

**Elena:** On his behalf and behalf of humanity: thank you. I have a last series of questions from my friend:

**Dan (via Elena):** When imprinting a thought or energy to be written into the crystal structure, is this where subtle energies are written or encoded?

**Jen Han:** Yes.

**Dan (Comment):** In the center of the vortex of the phase-conjugation node within the crystal lattice structure is where it is written I am assuming.

**Dan (via Elena):** The piezoelectric effect, which generates voltage when the charge triads are minutely physically displaced by pressure, appears to represent a means in which multi-dimensional holographic patterns can be stored and retrieved, along with its temporal components. Is this the storage mechanism for the med beds to reform our physical body?

**Jen Han:** There is a very precise, specific pressure that you can apply to quartz, that will activate the compression node and open the vortex. The energy produced can be tremendous. This kind of operation must be conducted knowledgeably and wisely. Crystals can store data just as water does, because constructed on the same fractal core formula, but crystals have way more capacities. Of course, they are the most elaborate state of matter. So elaborate that it naturally embeds consciousness. To answer this question: some med-beds technology use fractal holographic technology. Let me explain. The fractal core formula of the tissue to repair is recorded, and the perfect unaltered geometrical pattern is reconstructed and superimposed on the damaged pattern. The old pattern instinctively pairs and morphs into the new one, because the universe tends to perfection. It is a holographic fractal re-pairing. Sound frequency is used to “tie in” the new pattern to the old one. You remember how I explained earlier, that holographic structures are constructed or either altered by frequency?

**Dan (Comment):** This slight squeezing pressure on the crystal is what Dr Vogel discovered assisted in resonating with the DNA frequency signature of the person using the crystal. So as to become one with the crystal. He found that rotating it in his hand while rubbing with a slight pressure assisted this resonance coupling to the individual.

Apparently the crystal has the ability to store the fractal holographic pattern of an individual including the temporal elements. In other words within the fractal holographic pattern you have the ability to tune through time of that holographic pattern going back to the moment of conception of the physical being you have recorded and stored as a holographic pattern within the crystal? As Alex Collier described.

**Dan (via Elena):** What is the relationship between the 52 degree angle that is shared by both the Great Pyramid and quartz crystals?

**Jen Han:** This is a ratio that acts as a transponder. It is dynamic geometry. Some shapes, just because of their proportions, naturally affect the holographic structure of the matrix. We use this specific pyramidal ratio to build our Phryll generators. Because the geometrical structure of the central crystal, in a generator, will interface with the pyramidal ratio of the building or the machine harvesting its energy.

**Dan (Comment):** 52 degree angle of the Great Pyramid on Terra is directly related to Phi or the 1.618 ratio which is expressed throughout nature and resonates fractally into infinity, so this makes sense in regards to the Pyramid and quartz crystal having this specific angle to transpond to this matrix.

**Elena:** How does a central crystal, in your generators, produce Phryll? Because the pyramidal structure with an angle of 52 degree is a harvester, right?

**Jen Han:** Not only harvester: transponder as well. The central crystal generates energy because the vortex if open.

**Elena:** Ah....

**Jen Han:** Anticipating your next question: it is activated by sound. Well to be more precise: by a frequency key shot at its compression node.

**Elena:** Jen Han thank you... I am sure my friend Dan will appreciate. Can we do that again ?

**Jen Han:** Yes! My pleasure to be part of your little stories on Terra! Salute your friend Dan for me.

-----

**Dan (Comment):** Thank you so much Jen Han for your insights into crystal technology relayed through my dear friend Elena! We shall use this knowledge in the interest of empowering the beings of Terra in the use of a crystal to resonate with love and the intention to manifest a positive timeline for our beloved planet for all beings.

## **Jen Han Eredyon Session – 2022**

Dan: First of all, Elena and I are very grateful and wish to thank you for assisting us in understanding this crystal technology in order to empower the beings of Terra to assist in effectively co-creating a positive timeline for our planet.

*Jen Han: I have something to say to this, first of all thank you Dan for performing this global training for humans of Terra, and to guide them towards their own personal power. I didn't know things were that concerning on your planet. I never truly wanted to interest myself into the events that are going on on your planet, and also, my brother was keeping me safe, away from this great battlefield. Did you know that I wanted to become a pilot and my brother forbade me to. I believe he wanted to preserve me from potential danger because he loves me. I watched the recorded training sequence with the crystals, that you did with Elena, and I liked it. My words were well and clearly transcribed. Also the information I gave you. Yes, I can say that I am happy with your production.*

*I didn't know how bad the situation was on your planet, Dan. I am glad that now, everything is taking the right turn and the good people of Terra made agreements with our Federation. One day I hope you will come and visit me in Manahu (the Pleiades).*

*We may start your questions.*

1) If you have watched the video Elena and I made titled “Creating a positive timeline in the planetary matrix using a crystal”, the procedure we did with Elena’s viewers

- A) Do you think it was effective?
- B) How can we improve the effectiveness?
- C) Are the Vogel cut crystals significantly more powerful than a natural single quartz crystal points for doing this work?

*Jen Han: I know it was effective, because the wording and the knowledge were right, so the impact on the planetary morphic grid was effective. You can improve the effectiveness by preparing the people longer beforehand. It is good if they are in Gamma brainwaves before starting the work. Gamma brainwaves open the vortices in the*

person's mind and anything becomes possible. I know you do not have the technology but try find a way, maybe by meditation as you call it.

ELENA: Wait, I can create Gamma binaural frequencies with a set of tuning forks I have, would that work?

Jen Han: is that directly projecting these sound waves into the brain of the auditors?

ELENA: yes I can do that, coupled with meditation. Any other tips to improve the effectiveness?

Jen Han: tips?

ELENA: recommendations

Jen Han: deep inner state of awareness is required if you wish to improve the work.

ELENA: so please what can you say about question 1-C): Are the Vogel cut crystals significantly more powerful than a natural single quartz crystal points for doing this work?

Jen Han: Oh yes they are, if it is cut rightly. In perfect alignment with the grid of the lattice.

2) In a previous communication Elena drew the following...

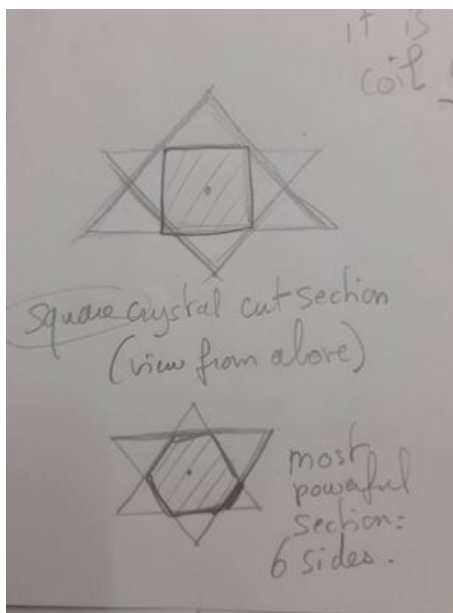

We have interpreted this to mean it is “most powerful” to cut the crystal so that the 6 natural sides or axis of the lattice of a quartz crystal are cut as a Vogel crystal to match as in this illustration

The angles of the 6 natural facets of the raw crystal material need to match exactly the 6 facets of the 6 sided crystal that it will be cut from.

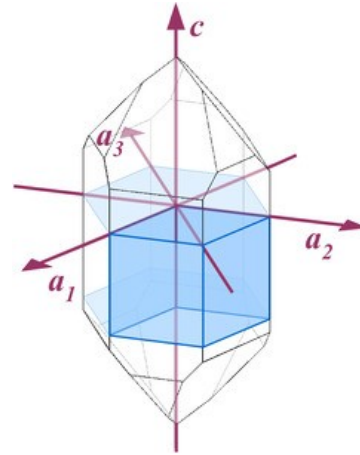
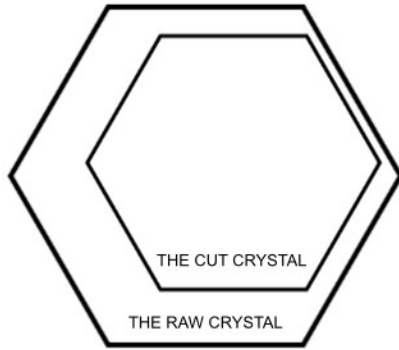

*Jen Han: yes this is correct*

By cutting the Vogel crystal with 6 sides in this manner, when physical pressure is applied it would be the optimal natural angles of the lattice structure that would be exactly perpendicular to the structure of the lattice, and therefore would yield the greatest piezoelectric output in voltage.

*Jen Han: That is correct*

The 6 sided Vogel cut crystal would be formed in this manner with 52 degrees on one end and approximately +/- 60 degrees on the other

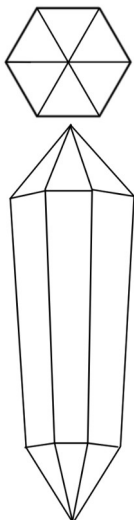

*Jen Han: it must be 60 exactly. The receiver end is 52 degrees angle because it is a geometrical shape that harvests energy and electricity. It keeps it until it is released by two means: naturally with a long period of time, or with a simple basic technology that transforms the receiver into a generator.*

*ELENA: I feel there is a lot to unpack there can you develop please?*

*Jen Han: It is simple. When you want to create energy you need two things: basic physical elements and a formula. The formula is the guiding way you will arrange the elements together to create technology. For a technology that will produce energy supply, basic elements include a perfect crystal, and a 52 degree angle container. If the crystal is cut following the lattice angles has a 52 degrees point, it will harvest Phryll. It does it naturally but relatively faintly. The 52 is the harvester. 60 or 65 is the sender. What was your question?*

*ELENA: I was just mentioning the angles, thank you. We're going to have a lot of questions just with this answer you just gave...but let us see first these following questions from Dan:*

### **Reference Jen Han previously stated:**

*“It is not male and female as biological terms but active and receptive. The two dynamics twirling in opposite directions create a phase conjugated tension that creates singularity in the hologram. A convergence of infinite power.*

*The singularity is in the vortical center, not metric center. The two triads are not equidistant from the singularity nor symmetric either; because their ratio, and their distance from the epicenter, are determined by the different angles of inclination of the two points. It is not a physical node but an infinite singularity, which is different.*

*It works by finding the phase-conjugation node inside the crystal, by projecting inwards the geometrical shapes of the two opposite points, like a mirror. There, is the vortex singularity of the crystal. Focus your thought and energy just there, and you may project your consciousness to anywhere you wish in this universe, and the other universes. To other densities, other dimensions. Anything is accessible in space, dimension and time. This is great power, Elena. It is a very important information. I am honored to be allowed to share this with you.”*

Elena received the following image of your description of the vortical center within the crystal... Is this correct?

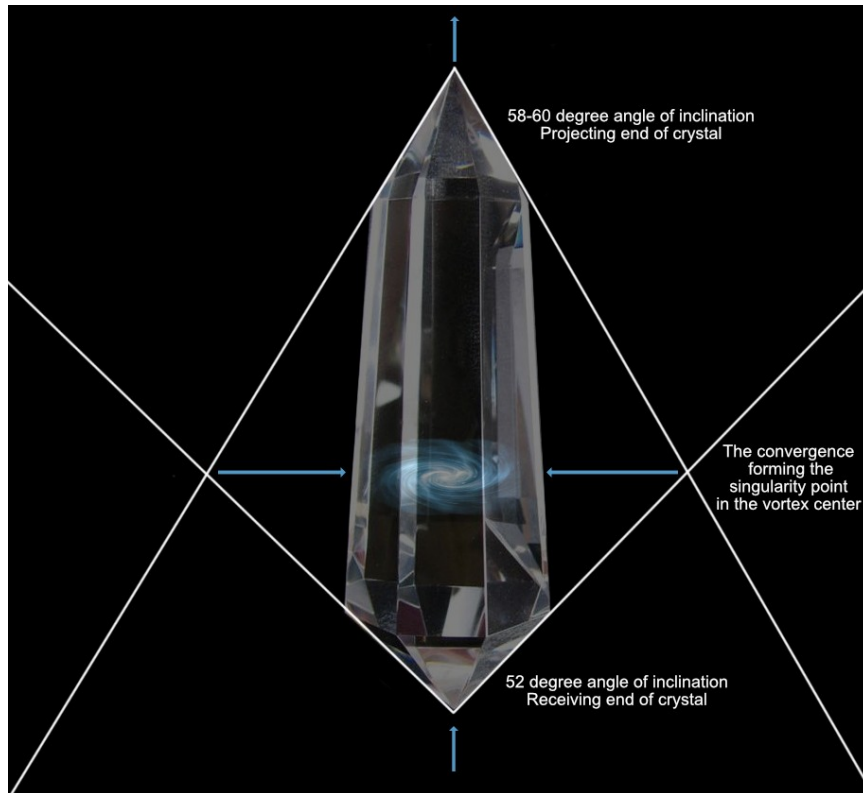

*Jen Han: yes that is correct. It doesn't create a galaxy, although it can. Do you understand?*

*E: Is that humor?*

*J: Yes. I was judging your picture but I want to seriously say that this science is used to create worlds.*

*E:I wanted to represent a vortex. Is that right? Is that where we need to apply the pressure, either sides of this precise point?*

*Jen Han:That is correct. The shape is correct. This is what you call Merkaba.*

*E: Yes!*

*Jen Han:this is like a machine that can create anything, this is great power.*

**Reference Jen Han previously stated:**

*“There is a very precise, specific pressure that you can apply to quartz, that will activate the compression node and open the vortex. The energy produced can be tremendous. This kind of operation must be conducted knowledgeably and wisely.”*

Could you please clarify in greater terms exactly how to apply this pressure as you said “There is a very precise, specific pressure that you can apply to quartz” ?

*Jen Han: Sure. This is a sharp, pulsated, repetitive pressure. 20 pulse per second with metallic technology. Faster will work as well but the harmonic frequency with quartz is 20 pulses per second.*

*E: can't do that with my fingers...*

*Jen Han: with fingers, pulse in synchronicity with your breath. The soul activates the vortex in the crystal by projection with the breath.*

*E: Can you develop the “metallic technology” please?*

*Jen Han: Crystal reacts with close-to-pure conductive metals. They ring the lattice.*

*E: They ring the lattice?*

*Jen Han: they stimulate the electrons in the atoms in the crystal, until it changes the charge. At each pulse, the charge will inverse. Under a continuous alternate pulse, the crystal will generate Phryll energy.*

*E: Where... how... where does this Phryll come from? Does the crystal create it from the ether?*

*Jen Han: no, it comes from the singularity, that has opened. Crystal you name Quartz is in synchronized frequency with Source. So when you stimulate the singularity, you bridge to Source and you can draw energy from it. But be careful, you need not to perform this for too much a long time. It depends on the size of the crystal. There is a time/mass ratio that corresponds to the saturation point. Because there is a saturation point. After this point is passed, the crystal implodes. It becomes Light and transcends matter and density. It can be very harmful at this stage. So this is why we harvest Phryll and generate energy supply by sequences.*

*E: How can we know we reach the ratio point?*

*Jen Han: The crystal begins to sing.*

*E: sing?*

*Jen Han: You hear a faint whistle, that becomes louder. You need to stop there.*

How much of a physical squeeze is required?

*Jen Han: do not break the crystal but compress it enough that the charge of the mass is relocated towards the center. You do not need to force too much. What works is a repetitive action: a pulse.*

Is this pressure using our hand fingers to squeeze the area of the crystal that is near this vortical center indicated by the red dot?

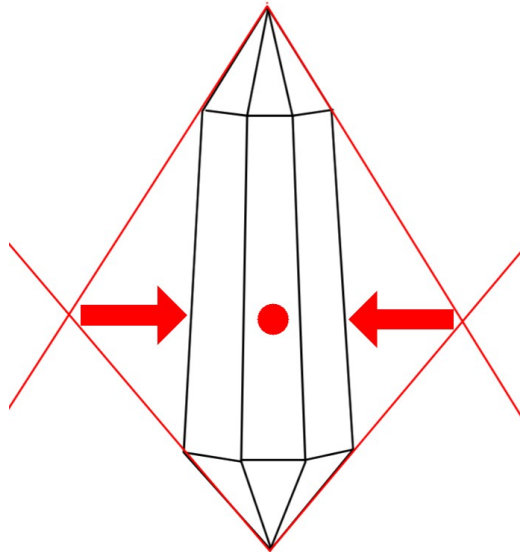

*Jen Han: yes correct.*

## **Reference Jen Han stated:**

*The pressure must be performed perpendicularly to the structure of the lattice.*

*The singularity is where is encoded information in the crystal.*

*This is what you want to compress for piezoelectric effect.*

*Two applications:*

*Do you remember, it is like breath: no slow long pressure, but a series of sharp, strong pulses. If you apply constant long pressure, it will accumulate charge and become a generator. If you apply sharp quick pressures, it will stimulate the singularity and pierce through the hologram, you can then use the crystal as a tool to modify the hologram.*

*You will “feel” the appropriate rhythm of pulsation.*

*You can also feel it with your mind, where the power center is. Your being recognizes it.*

*It pulses faster than light, your body and being recognize this. They feel it.”*

## **Regarding breath and physical pressures**

You stated that there are two applications, breath and physical pressure. Should the short bursts of breath be synced (done together at the same time) with the sharp physical pressures on the crystal?

Or just the breath pulsed once and multiple sharp physical squeezes of the crystal?

*Jen Han: Both work but I would recommend synchronized breath and pressure. I repeat, you do not need to go as fast as you can. 20 pulse a second is for metallic pulse. Human soul and body are a different transponder. Find the rhythm that you feel works for you. There is another way I haven't mentioned yet: Metallic pulse and breath. It is impossible for a human to breathe at 20 pulse per second, but this works too: Sit in front of the crystal that is wired for metallic pulse, and send your intention with your breath into the crystal, not touching it because your own body electricity will create a dissonance with the metallic wired pulse. You can couple both as I said. I hope the Terrans will understand.*

*E: wait... you said “crystal wired for metallic pulse”? Can you develop please?*

*Jen Han: Metallic pulse can be induced two ways: by two small electrodes either sides of the singularity point, or by two wires spiraling in opposite directions around the crystal.*

*E: now we're talking. We'll have to develop this topic next time, as I have limited time with what I can bear with the implant's statics.*

You stated that you can feel an appropriate “rhythm of pulsation”, is the duration of this pulsing action required for very long to pierce through the hologram in order to modify it with a vision of a positive timeline into the planetary matrix?

*Jen Han: Oh yes of course, as I said previously, you can practice until the crystal sings, but if you are sensitive enough, you will “know”. On your time frame and your density: a few minutes, not more than ten, should work. But you can continue until the crystal sings.*

The “power center” location you stated is then to be felt with the mind. If for some reason it is not felt, is it still effective to imagine this power center within the crystal if it is not felt?

*Jen Han: If you do not feel it with your mind, you are not connected to the crystal's central vortex. You need to have the connection if you want to imprint an intention into the planetary matrix. The new template of reality cannot bridge to the old, otherwise.*

If the participants do not have a Vogel type crystal and only have a single quartz point, is there any suggestions to help make their impact into the planetary matrix more effective?

*Jen Han: It works with any kind of quartz, at the condition that the lattice is respected. If not cut in resonance but cut in dissonance regarding the lattice, the crystal will not harvest. Natural raw quartz are of course effective, but the Vogel cut as you name them are a more surgical tool to operate into the fabric of space-time and universal consciousness.*

## **The importance that the crystal is cleared first**

### **Jen Han stated:**

*“The energy force that is a living manifestation of Source is being impregnated inside the crystal but beware, the crystal must be empty. This means: no residual emotional imprint, parasiting or charge. The crystal must be pure and clear from any form of energy, or consciousness even. I wouldn't say that at this stage, the crystal is really "empty", because it carries its frequency imprint, but I mean empty from anything that is*

*not the original frequency signature of the crystal. In order to perform this action: embedding a fractal of your consciousness in a dynamic projection, into the crystal, the receptacle must be pristine pure. There are methods of purification I can tell about, the best is to run the crystal through a sound scan. You need instruments that create a high frequency sound, or trained persons can clear a crystal with their own consciousness. These individuals have reached a clear state of mind.”*

### **Questions:**

In stating that “*or trained persons can clear a crystal with their own consciousness. These individuals have reached a clear state of mind.*” Is it sufficient that a person who sets their intention to clear the crystal along with the pulsed breath, or is more required?

*Jen Han: The clear state of mind is a mind with no parasitic thoughts. A mind as clear as crystal or pure spring water. A mind in higher frequency, content and in perfect harmony with the universe. You cannot clear a crystal with your mind if your mind is troubled; you will project your parasitic thoughts into the crystal instead!*

Dr Marcel Vogel was able to measure this clearing with intention in water with pulsed breath and also by using a magnetic eraser. The magnetic eraser is a device used to erase magnetic tapes and produces a strong magnetic field that alternates its polarity 60 times per second.

Since the clearing of the crystal is vitally important and we do not have a “sound scan” or the specifications for such an instrument, would either the intention with pulsed breath or the magnetic eraser suffice in clearing the crystal for our purposes? Or do you have another recommendation?

*Jen Han: The mind is enough, if you do not have technology, but your mind must be as clear as spring water and empty of any thought. Otherwise the clearing doesn't work; you just transfer other thoughts in the crystal.*

## Finding the phase-conjugation node

### Jen Han stated:

*“It works by finding the phase-conjugation node inside the crystal, by projecting inwards the geometrical shapes of the two opposite points, like a mirror. There, is the vortex singularity of the crystal. Focus your thought and energy just there, and you may project your consciousness to anywhere you wish in this universe, and the other universes. To other densities, other dimensions. Anything is accessible in space, dimension and time. This is great power, Elena. It is a very important information. I am honored to be allowed to share this with you.”*

*“It is not male and female as biological terms but active and receptive. The two dynamics twirling in opposite directions create a phase conjugated tension that creates singularity in the hologram. A convergence of infinite power.*

*The singularity is in the vortical center, not metric center. The two triads are not equidistant from the singularity nor symmetric either; because their ratio, and their distance from the epicenter, are determined by the different angles of inclination of the two points. It is not a physical node but an infinite singularity, which is different.”*

### Question:

Is the understanding correct in how the phase-conjugation node within the crystal is created... That the angles of inclination of the two end terminations each create a vortex of energy, as similar to within a pyramid, and because of the reflective optics within the crystal are “mirrored” as exact opposites in their vortical flows which converge together to create within the center of these two opposing vortexes, a singularity point that is, by it’s nature, connected to all points in the hologram?

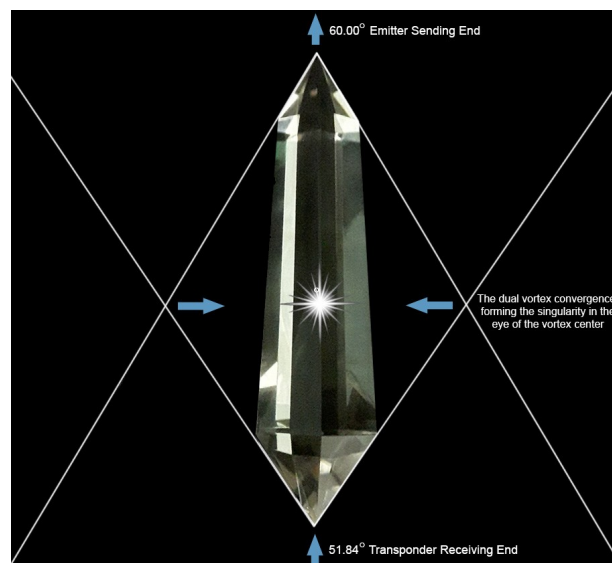

*Jen Han: That is what I showed to you on the first time. I made Elena draw something. This is correct. The vortices open holes in the holographic reality, allowing the anchoring of imprints.*

Is the understanding correct that this phase-conjugation node is more related to the spinning vortexes of light (optical) of the two terminations than the molecular direction of either right or left handed spiraling within the crystal?

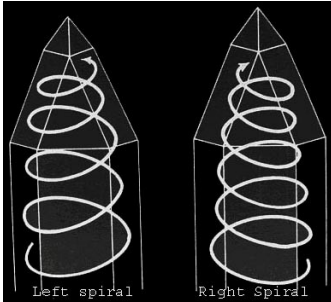

*Jen Han: Oh no these are two different aspects. The singularity node is a bridge to alter the hologram of the universe. It is a small wormhole. The two spiraling molecular directions have to do with the power core of the crystal in its natural state, not its ability to transcend densities and anchor into the holographic grid of the universe, that works with the wormhole.*

From what you described, this singularity point created would be the most powerful place to imprint an imagine into the planetary matrix and it is something that must be “felt” as to it’s exact location?

*Jen Han: It is best measuring it but by feeling it directly you already interface. If you first find it by measurement, you still need to interface: “feel” it.*

For all those who do not own a Vogel type crystal and are using a natural single point quartz crystal instead, I am assuming there is a great difference of effectiveness in piercing into the hologram? Do you have any recommendations for those with just natural uncut crystals?

*Jen Han: Natural uncut crystals work when they are not altered, what I mean is no breaks and cracks in the angles. It must be complete. We visited an Altean craft recently, that is why I am visiting this star system, to learn more about their terraforming science, and the way they use crystals in their ships, notably. The walls in the common areas are*

*made with natural crystals but these are impeccable, with unaltered angles. Otherwise they wouldn't bridge the densities.*

*ELENA: And another ten questions I have in mind now ! But let us go through this list for, and Dan has also more questions I want to submit to you.*

### **Crystal in each hand and being grounded to the earth**

#### **Jen Han stated:**

*“You take the mineral/ crystal in your two hands. It creates a current. Best is to have one in each hand but it works also with your two hands on one single crystal. Your hands must not touch. The current will work naturally. It is even better if you are in direct connection with the soil of the planetary matrix. You intend to make one with the planetary matrix. The crystal is the connector if you will. Quartz is best. Always works. Quartz is found throughout the whole universe. It is a fundamental component. You know you are in resonance when you feel it. It's like a shiver in your whole body, from your heart center. You may even hear the crystal singing the frequency of the planetary matrix.”*

#### **Question:**

For those with natural uncut crystals, having one in each hand you are saying has the best effect rather than two hands (not touching each other) on a single crystal. This would be more appropriate for uncut natural crystals than a Vogel cut since the focus with the Vogel cut is into the singularity point of that one crystal, correct?

*Jen Han: You are correct. This applies to natural crystals. If you have an especially powerful and pristine natural crystal, you can use this one alone with your two hands. Having one natural crystal in each hand creates a current. Think about electrodes.*

This group participation of imprinting into the planetary matrix is being done through the internet videos with people in front of their computer screens without their feet in direct connection to the soil of the planet. The question is, is this a vital component of this process and can it be facilitated by electrically grounding the participant using a grounding electrical wire connected to an earth ground?

Note: This can be achieved by an electrical connection to the body by a wire from an electrical outlet that includes a ground connection to earth.

*Jen Han: I do not know about the wires you are mentioning. This is a procedure alien to me.*

*(this made me chuckle and I explained to Jen Han about our primitive way of making electricity using wires. And he replied this:)*

*Jen Han: This seems dangerous. Having you feet on the ground of the planet is the best way to interface with the planetary matrix but if you stand in a building on this planet, you are also interfaced with the planet because you are within its grid.*

*(I explain to him that this is not dangerous and I ask the same question again)*

*Jen Han: Yes you can do that. With a wire. But I there are also other ways, such as anchoring your consciousness to the body of the planet. You interface as well, indirectly. It is more fain but it still works.*

*(I had to smile that Jen Han was discovering our barbaric way to make electricity)*

Thank you again Jen Han, as you can see there is a great response from the people of Terra to feel empowered to do whatever they can to move their planet's timeline into a positive reality. This information is invaluable. We are indebted to you for your sharing of knowledge and wisdom to help our planet.

Dan

*Jen Han: There is no debt in sharing knowledge. I was granted authorization to do this with you both.*

*THOR HAN: It is us, Dan, who are grateful for your efforts and good will. We are working together.*

*ELENA: Here are the additional questions for today:*

**Question:**

Can we use a bulk-eraser to clear a crystal?

**Question:**

Jen Han said the sender angle end must be exactly 60 degrees, but then later he says 60 or 65.

*Jen Han: It is 60 for the small crystals you are using. The very big ones used in our generators can have 60 to 65 degree angle for the point, it works, although 60 is always best.*

**Question:**

The Merkaba created within the crystal :

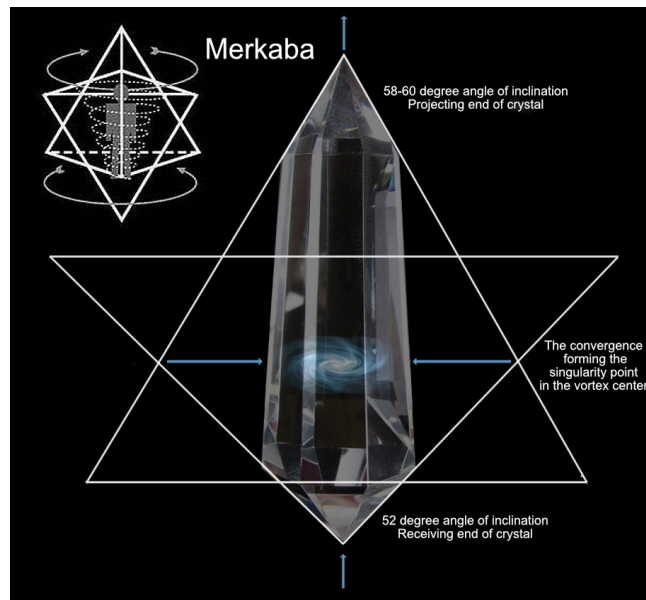

It appears there are two levels of activation of the crystal.

1. For the general public

Using a single natural crystal point. Or two, with one in each hand

Or a single Vogel inspired or cut crystal

Pulsing the breath and squeezing the crystal in sync together

## 2. A more specialized advanced application

Operator is not touching the crystal which is being pulsed at 20 pulses per second  
Brainwave of operator at 40 Hz Gamma (various methods of entrainment can be used)  
Electrical ground to operator's body according to first set of questions

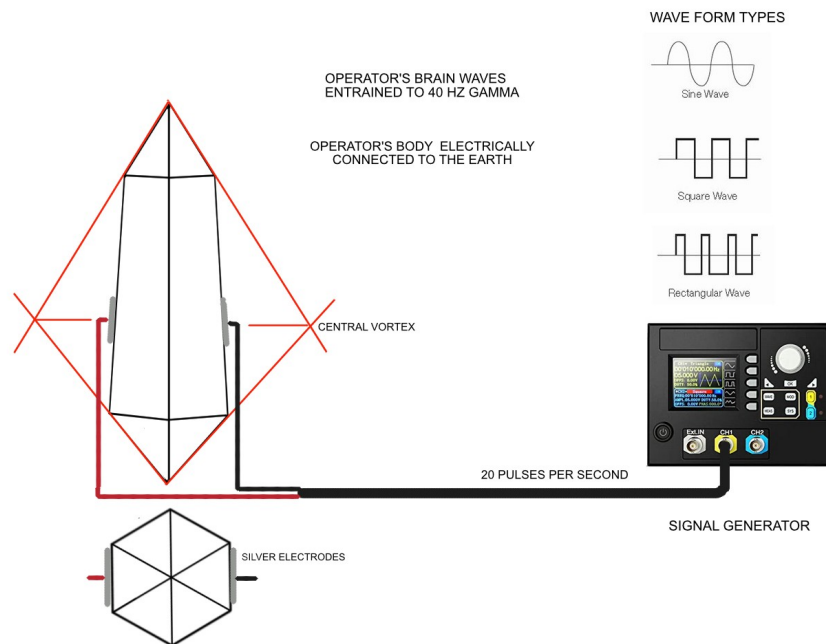

The clearing the crystal is very important. Will a strong alternating 60 times per second magnetic field (i.e. bulk demagnetizer) serve to clear the crystal?

*Jen Han: A powerful magnetic field can clear a crystal because it de-programs it. The crystal is then empty from any programming.*

*ELENA: So a device that would clear electro-magnetic programming is good? I think about a device we use here called a Bulk Eraser: a device for erasing previous recordings on a magnetic tape. I know it doesn't probably mean anything for you but..*

*Dan says: Its a strong alternating magnetic field that alternates at 60 times per second. On earth they are called a bulk demagnetizer to erase magnetic tapes*

*Jen Han: It sounds like it can work. Good device. I like it better with the mind.*

*ELENA: Yes but rare are the Terrans who can do that for now with their mind.*

*Jen Han: Why not train them?*

*ELENA: This is hard job, you have no idea. OK I have something else received from Dan today, what are your commentaries please:*

**Illustration of the two windings around the crystal.**

One is clockwise (CW) and the other counter clockwise (CCW) and both terminate together at the ends which are feed the 20 Hz signal

The windings could be much tighter and many more turns, but this is for illustration

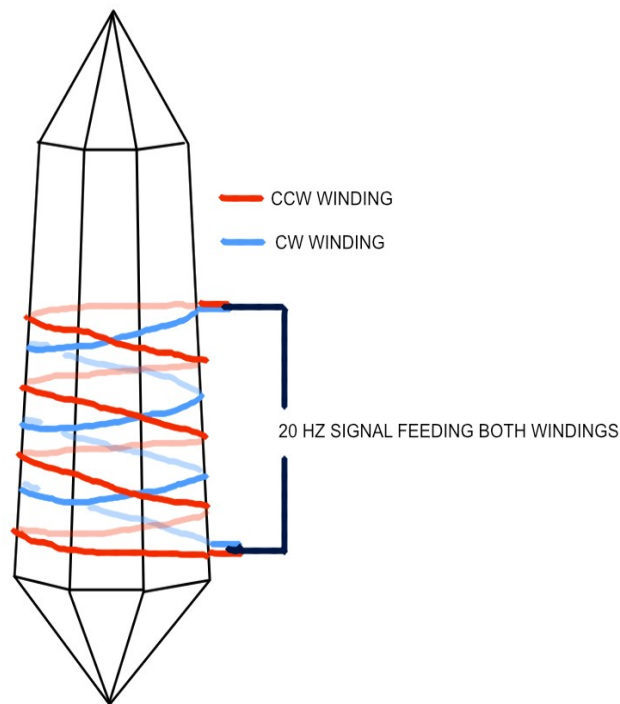

*Jen Han: This is exact, a small generator! You know that you can send the pulse with your mind, your mind is a device. There are other ways also. This is contact pulse. Our generators do not work with contact pulse. They work with resonance pulse. By signal sent to a receiver connected on the wires. The pulses can also be projected by other crystals, placed around the central crystal. You understand?*

*ELENA: I know where you are going.*

*Jen Han: This has nothing to do with the vortex imprinting thought-consciousness into reality, you understand? This has to do with the production of energy supply. If the energy produced reaches to a certain level, the vortex implodes.*

*ELENA: That's when it sings just before.*

*Jen Han: Yes.*

*ELENA: Ok so I feel I need clarity.. There are two things:*

*-Pulsing either sides of the compression node, that you call singularity, to activate the vortex in the crystal, and access the hologram of reality, and imprint thoughts in the planetary matrix.*

*-Then you have the generator of energy, with the two coils and the pulse.*

*These are two different applications, right?*

*Jen Han: The compression of the node by pulse, generates a piezoelectric effect, which can make the crystal sing as well if you misuse it. The vortex is used to bridge: creative thoughts, densities, and other things. The two opposite coils are a way to produce energy supply but it doesn't bridge an intention into a matrix. At a certain level it opens the singularity vortex if there is an overload. The crystal sings. That is why the generators are not pulsed continuously but by periodically, by sequences. With a small Vogel crystal using the lateral pulse to open the eye, you can make the crystal sing if you pulse it for a long time, a very long time. You asked me this question already and the time depends on the size and the capacity of the crystal. You will feel statics before it sings. The small Vogel crystals used as such, are not dangerous. The big generators with the coils are.*

*ELENA: Jen Han thank you so very much. Mentioning statics, I have reached my limit. Will you be willing to answer more questions tomorrow please?*

*Jen Han: My pleasure. I have nothing else to do on this station.*

## **Jen Han Eredyon Session – 2022**

The messages from Jen Han and Thor Han are heart warming to hear them express their encouragement for what we are doing!

*TH: Dan is a good man. He came to bring knowledge to the people of Terra. He is a messenger who opens the ways.*

*J: I am glad to work with him because he has the understanding.*

*E: Well it us who are grateful to you, dear Jen Han. Here are the additional questions, we were slightly confused with numbers:*

### **52 degree angle more exactly:**

For clarification, when we refer to the 52 degree angle which acts as a responder in the matrix, is it more accurately 51.84 degrees? Like the great pyramid is not exactly 52 degrees, but very close at 51 degrees 51 minutes or 51.84 degrees.

*(TH needed to show his brother what it was about)*

*J: Oh I understand. The most accurate is 51. 843 angle degree. 52 is in your metrics a general ratio for interface and it corresponds to specific mathematics. You understand, there is a range of angles, such as 60 to 65 degrees, and 51 to 52, that work for the same purpose, with different applications. The ratio of the dimensions of this pyramid is the most exact as it corresponds to a universal value which is light. Geometry generates frequencies. I told you, remember: quartz, light, love, water, have the same frequency. A small crystal functions with a 52 angle. As I mentioned to you previously, angles are adjusted for very big devices.*

*E: Why? That doesn't make sense..*

*J: Because of the bending gravitational field and electromagnetic field of the planet. A Vogel crystal the size of this pyramid should be 51.843 degree angle because it needs to be perfectly accurate, but very small crystals can function at 52 degree angle as it is less affected by these fields as much as the greater generators are. Although it is best they have this 51.834 ratio of course. Here also, you do not want to produce energy supply but affect the holographic grid using the eye of the crystal to crystallize then project a conscious thought.*

*E: I like it, that you said: “crystallize a thought”.*

## 20 cycles type of wave form to crystal:

On the signal generator producing 20 pulses per second. What waveform would be the most efficient to open the vortex within the crystal to bridge and imprint a vision into the matrix? I suspect a Rectangular or a very sharp Pulsed wave form?

### WAVE FORM TYPES

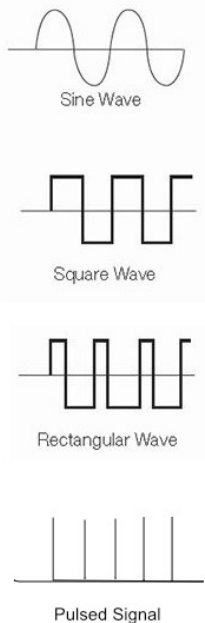

*J: The last two ones, the Pulsed signal is the most efficient but Rectangular works well also. Remember, sharper is always better. It can be faster than 20 pulses per second of course but 20 is a good vessel for consciousness. Do not forget consciousness. 21 also works. Also work for a single monotonic pulse: multiples of 20 such as 40, 80, 160, 320 and so on. Another method is progressively increasing pulses from 20 to 30 to 50 to 80 to 130 to 210 to 340. It is the geometrical measure of vortex's horizon curve. After 340, if you follow this order, the crystal can sing at 550. If you pulse directly at 550, it will not sing. What makes it sing is that you follow the order I gave you, from 10 to 550. but you don't need to do that. To carry a human thought-form through the crystal's vortex to imprint the hologram, breath pulse works and singular 20 pulse works. I sense an experimental mind in Dan.*

On Terra the metal element of silver is the highest conductivity, so we should use silver electrodes on the flat surfaces of the crystal as in this illustration?

*J: yes. We do not have silver easily accessible where I live, we trade it expensively or we make it. You have it abundant naturally on Terra. Silver is a metal that has a close radiance and frequency to light. This is powerful, my friend. Make sure it doesn't sing.*

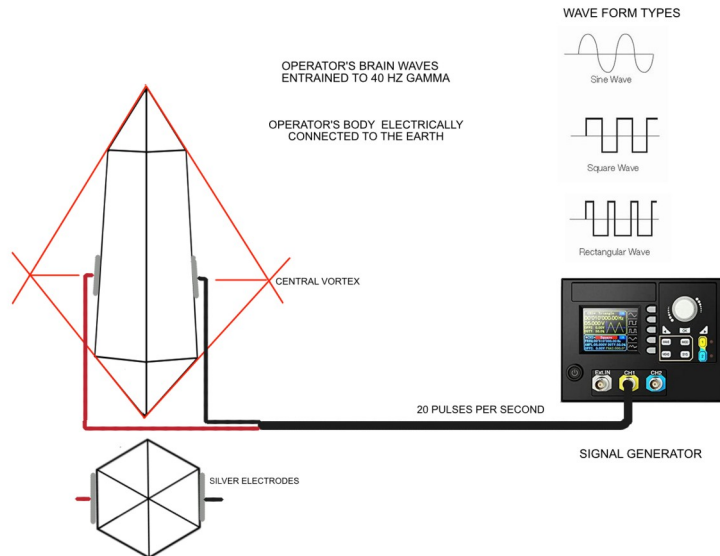

When operating the crystal as in the above illustration should the 60 degree angle be pointing upward? (*Marcel found the crystal direction was critical for some applications*)

*J: To imprint the morphic grid and alter the hologram, the 60 degree angle will point like a projecting beam to re-write the hologram. Yes it points upwards, aligned to the radius of the planet. This is important, related to the electromagnetic field and the bending gravity if it is a big crystal. Gravity bends light, so it affects also the toroidal field of the crystal. Some generators have the sharper point downwards for other reasons, but for the work you want to do , have it upwards.*

Once again, thank you Jen Han for assisting us in our understanding of this crystal technology that can empower the Terrans to affect their planetary matrix to help usher in more rapidly a positive timeline on Terra.

*J: My honor, friend. I must travel back to my world but we will exchange again soon.*

## Jen Han Eredyon Session – 2022

Hello dear Elena,

Please extend our gratitude to Jen Han and let him know that the knowledge he has shared has greatly expanded our understanding of these sciences, of which we will use solely for the good of all beings on our planet Terra.

Once you and I have both activated the singularity wormhole with the signal generator pulses as Jen Han has described and have some experience in connecting with our mind into the eye of the crystal to crystallize then project a conscious thought for a positive timeline on Terra, we may then have some additional questions based on our experience.

Thor Han started by giving me the answers that Jen Han had provided in return to the list he sent him a while ago. Thor Han says that the a specific question about energy is not allowed to be answered before the end of the month of September, for personal safety reasons. He mentions some scientists working for the “dark servants”, could get in the way. This matter will be answered after the month of September. What happens in September, he didn't say.

### 1 ) Reconfirming the arrangement with 20 pulses per second to open the singularity wormhole

Our specially cut 6 sided Vogel crystals in alignment with the natural hexagonal lattice is placed in a stand with the 60 degree sender angle pointed upward.

Thor Han: Jen Han said that it is correct. He is glad he was asked to double-check before you start the activation.



Very sharp and narrow electrical pulses at 20 per second at 15 volts amplitude from the signal generator are sent to the pure silver discs on both sides of the crystal's compression node vortex center.

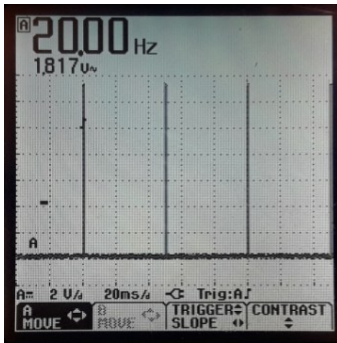

15 volt spikes at 20.00 Hz



Elena's crystal holder using a hexagonal candle holder framework to suspend it

Thor Han: Jen Han said that the 15 V is most efficient, and that it also works at a lower voltage but it needs to send a sufficiently powerful pulse and 15 V is efficient.

Before activating the singularity wormhole, mental preparation is done to enhance Gamma brainwave activity. Once activated and sitting in front of the crystal without touching it, we go with our mind to feel and connect to the singularity wormhole in the eye of the crystal.

Thor Han: I know you will prefer that my brother answers this one directly. I have the connection now.

Jen Han: Your settings are good, you are creative. We commonly use anti-gravity to hold a crystal device clear from any physical interference. I was shown Elena's holding structure; a lot of metal around but it will not affect the results. It is not an interfering metal. 15V is an efficient amplitude. Regarding the brain tuning into Gamma wave, we do this without effort because our brain frequencies

are cleared. On Terra, the bodies you occupy have been poisoned with low frequency chemicals, in your food and in your water. But for those like you Dan, who have a clean natural diet, it is easier to tune your brainwaves at will. It is a matter of confidence, it really is. And I weight these words with great importance. Self-confidence is a crucial condition to tune your brain into Gamma. When you are familiar with this activity, you do it without crystal. But why not use these tremendously powerful tools at our disposal! The universe is filled with gems for us to pick. Source provides the tools that we need. Always. You can use technology to create Gamma brainwaves and the tuning forks Elena has are effective too. Yes it is not necessary touching the crystal while you perform the brain translation into Gamma. Then the brainwaves will propagate through the ether into the crystal, through the lattice, with purity, clarity and efficiency. Know that the skin shares chemicals and when a physical connection is made with the crystal, the power of consciousness will interface. Firstly, produce the Gamma brainwaves.

Dan's Comment: I asked Elena how does Jen Han know what my food diet is like?

Elena left me a voicemail and said...

"Well, last night I was beamed on board Thor Han's ship, but I didn't stay long, about 15 minutes, minutes, and Jen Han was there, that's why he beamed me up, asked me if I wanted to, of course I always say yes, even if I'm sick, and I always do say yes. Jen Han was here because he was momentarily passing by, staying with him on the station, and that was nice to see him, is practically the same size as Thor Han. Well, yeah, it was really nice, so he said so where are your questions?

I don't have my notes with me I said, we need to do it the regular way that I'm on Earth and I take notes, otherwise it's not good. I need to transcript your words as they are, so we are meant to do it tonight regularly, and while he's still on Thor Han's ship station, it's easier for them to do that.

Also, Jen Han is having another study trip with the Intergalactic Confederation is on the Altitan ship at the moment, working with them, learning from them, and he wanted to know about the fact that if he could live with them to the galaxy for temporary study, but he needs to complete first his training at the Pleiades University in Terraforming and then he would be able to go to their galaxy and learn in their world anything more. Because Jen Han said you imagine they are 20,000 years more advanced than us. And so he said it's amazing what they can teach us, it's mind blowing. And he was so excited and said no, you need to finish university first. That was so funny, it was like on Earth, young person was amazing. And I said when will you finish university? Said that's not the same amount of time, time doesn't pass the same way. So he wasn't able to tell me.

Then I asked him the question, how do you know about Dan's diet? And he laughed and he said well, do you think that we give information like this to people, random people, without scanning them and scanning them constantly? So he said, for example, safety, and he doesn't know what you eat, but he said everything your diet shows up in your frequency signature, so he knows what type of food you eat, not exactly what, you can't see that, but it says the frequency of the food you eat because it's in your aura. So that's how he explained it. So now he confirmed that you are scanned and protected and since this information were given to you, now you constantly looked after and that you don't have anything a big problem and that's it. So that's nice to know, that's what I want to say. Here we go. And then I had to go. It was just a short trip."

Once that connection is felt and established, we visualize in our mind's eye in as much clarity and totality as possible a positive timeline on Terra.

Jen Han: Yes. Always set the trajectory beforehand.

When that conscious vision has clearly formed, we then project that into the eye of the crystal using our pulsed breath to crystallize it into manifestation in the holographic grid of the planetary matrix.

Do we have this correct?

Jen Han: You have this correct. You put the seed into the crystal. Now you will activate the vortex.

## 2 ) Crystal with metallic 20 Hz pulse to open up singularity wormhole the most effective?

Jen Han: It can be slightly higher but I recommend you keep it at this threshold, regarding the magnetic field of your planet and the size of the crystal. You don't want to break it.

**Reference Jen Han:** “I would recommend synchronized breath and pressure. I repeat, you do not need to go as fast as you can. Human soul and body are a different transponder. Find the rhythm that you feel works for you. With fingers, pulse in synchronicity with your breath. The soul activates the vortex in the crystal by projection with the breath. “

**Question:** Compared to using a Vogel crystal with just our fingers and finding a rhythm to synchronize with breath. Is using the “metallic” 20 electronic pulses per second considerably more effective at opening the singularity vortex within the crystal?

Jen Han: I will tell you this: you need this technology at this point in time, because it is more effective than what you bodies are, in average, able to do. But please know this: in a greater knowledge, you do not need this technology because your bodies are purveyed with natural abilities that can do that. You can literally project an electric field through the ether, with the simple power of your mind. Please make sure to tell Terrans to whom you will show this simple technology, that it works as well without this technology, as we spoke before, using their consciousness carried by the breath, and the pulse of their fingers. Of course, technology helps greatly.

## 3 ) Uses for the Phryll energy generation

**Ref Jen Han:** “They stimulate the electrons in the atoms in the crystal, until it changes the charge. At each pulse, the charge will inverse. Under a continuous alternate pulse, the crystal will generate Phryll energy. The Phryll comes from the singularity, that has opened. Crystal you name Quartz is in synchronized frequency with Source. So when you stimulate the singularity, you bridge to Source and you can draw energy from it.”

**Question:** Since we can stimulate the singularity in the crystal with the 20 pulses/second from our signal generators and the crystal will generate Phryll energy that we can draw from, can this Phryll energy be used for healing and regeneration since it is considered to be the essence of life force in the universe? I ask this because on planet Terra our Terran bodies, unlike yours that live for hundreds of years, degenerate and expire in an average of less than 80 Terran years, no doubt in part due to a lack of this regenerating Phryll life force. If yes, how might this best be accomplished? Or any other suggestions how one might best regenerate and optimize these Terran bodies?

Jen Han: The Phryll from Source is the most powerful energy you can ever imagine to harness. Of course, when the singularity of the vortex is triggered in the crystal, and when it bridges to Source, Phryll comes from it. If it is not harvested it will radiate outwards and propagate in the ether around in a halo. Reached a certain point of saturation, the crystal may sing. You know what this means. When you hold with your bare hands the crystal that is surrounded by a halo of Phryll, it regenerates your cells by invigorating and strengthening the bounds between the particles that compose it. But you know, you can do it yourself without the help of a crystal. You can harvest Phryll by yourself, in a more natural and safer way. Your DNA is composed of micro vortices, that you can activate with your consciousness. I can show you how to do this, it is simple but it requires a lot of practice. Once you complete this training, you can feed from Phryll and you need little food. You still need food of course to sustain your bodily envelop. Anything you will eat, will be several times more efficient, because the nutriments as well will be invigorated as soon as they enter your auric field. It will keep you healthy longer. If you wish to use crystals to extend your life expectancy, there are two ways: the natural way and the technological way, with the healing pods. You call them med-beds; those who work with crystals and water.

Elena: Can you remind us how to harvest Phryll with our consciousness? I know a method taught to me by Annax but I am interested to know yours.

Jen Han: First of all, you know about the method that consists in imprinting a younger and healthier template into the holographic pattern of your envelop, using consciousness. Harvesting Phryll to nourish and invigorate your cells is a different thing. You need to isolate yourself from mental disturbance and connect intuitively with the particles of Phryll present all around you. Or coming from an activated crystal if you will. It is better of course. But you can do it as well with the existent particles of Phryll present naturally in the ether around you. When you see them with your mind's eye, like a shimmering living dust, you can harvest them with the power of your thought. Absorb them. It is best to do it outside in open atmosphere, in the light beams of your star. Bare feet on the naked soil even works better because you create a current of energy with the planet and what circulates through you is quite powerful and regenerative. Simple, isn't it?

Elena: Yes indeed. It is quite similar to what Annax told me.

#### **4 ) Usefulness of Vogel cut crystals with multiple facets beyond the natural 6 sides.**

**Dr Marcel Vogel said:** “The large end of the Vogel crystal is cut to the same internal angle as the Great Pyramid of Cheops, 52 degrees. The large, female, end draws in Prana (aka Phryll, Vrill, Chi and lifeforce), which travels down the length of the crystal, being amplified each time it is reflected by a facet. This highly amplified Prana flows through the male end of the crystal where it is focused into a coherent, laser-like energy. Thus, **the more facets the more amplification.**”

**Question:** Marcel Vogel originally received a vision in a dream of how to cut the crystal into a DI-pyramidal form related to the form of the tree of life of the Kabalah.

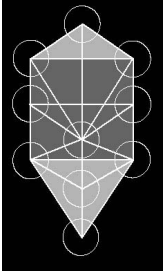

With 52 degrees on one end and 60 degrees on the other. He saw this form as acting to cohere the energies of mind similar to how a LASER coheres energy reflected between two mirrors, and that the energy spirals down the C-axis (growth axis) and he believed as he said “the more facets the more amplification”

**Jen Han:** This is untrue. Too much facets lose the focus of the beam, the lattice of the crystal is too much interfered in its dynamics.

He originally started with 4 sided, then 6, 8, 12, 13, 16, 24, 33 etc and since he stated the more facets the greater the amplification, some people have had even gone up to 377 facets cut for Vogel crystals thinking they are the most powerful, due to the amplification of greater reflective spin of more facets.

Marcel was unaware of the knowledge you shared, that the di-pyramid form he created formed within the crystal a Merkaba-like singularity wormhole and that it was the 6 sided Vogel that is cut in alignment with the natural hexagonal 6 sides of the lattice structure that yields the maximum piezoelectric response on the sides when pressure or electric pulses are applied, and that it is by stimulating this piezoelectric aspect of the crystal is the method to open that singularity vortex in order to modify the hologram.



When physical pressure with the fingers is applied to a multi-faceted Vogel crystal as in the above illustration versus the 6-sided aligned with the natural crystal’s hexagonal lattice, there is a small chance that the pressure will just happen to be perpendicular to the natural 6 sides the crystals lattice structure and yield much of a piezoelectric response.

**Jen Han:** That is correct.

The Terrans use these multi-faceted Vogel cut crystals in energetic healing to bridge the various densities of the body and through intention and breath to release dissonant patterns in the body.

**My related questions are:**

Does increasing the number of facets of a multi-faceted Vogel crystal yield greater amplification as Dr Marcel Vogel assumed?

Jen Han: No. It will magnify the healing power by radiance, the crystals that are multifaceted to an extreme are transmitting life energy by radiance but they are not the most effective when opening the eye of the crystal, because the dynamics is lost. You need to respect the structure of the lattice, and always cut in perfect ratio with its hexagonal core structure. The efficient shape of these crystals do not only concern the correct degree of the two pyramidal extremities, but as well the lateral ratio: the facets. Everything must be in harmony with the core lattice. Vertically, and laterally.

Are these multi-faceted Vogel crystals really any more effective at energetic healing than a 6 sided Vogel that is cut in alignment with the natural lattice?

Jen Han: As I was saying, they are healer crystals, but compared to a near-cylindrical shape dynamics. The more it tends towards it, it loses its power. 4, 6, 8 and 12, even 24, works. Afterwards, the vortex effect decreases.

Is there something of value of the multi-faceted Vogel crystal for energetic healing or for other applications?

Jen Han: I answered this question already.

Is the 6 sided only suited mostly for the application of imprinting into the singularity wormhole to modify the holographic matrix or for generating Phryll?

Jen Han: You can also heal with this one, because it is the most effective tool on manipulating the fabric of reality. Imprint the healthy element onto the defective one using the vortex. You know, and I shouldn't say that because it will open a new conversation, but you can interface your Pineal gland with the vortex of the crystal and travel distances and time by projection of consciousness. Another time maybe.

**5 ) If the planet's brainwave affects minds then can many minds affect the planet's brainwave?**

**My question:** Is there a reciprocal connection between our planet's ionospheric cavity which resonates signals similar to human brainwaves and human brainwaves?

**More details:** Physicist W.O. Schumann postulated mathematically that our earth and ionosphere constituted a cavity waveguide whose physical constants and magnetic field would oscillate at a resonant frequency identical to the range of human brain waves. Instrumental recordings of these signal tracings are indistinguishable from encephalographic recordings from human brain waves. This newly discovered phenomenon was dubbed the "earth brainwave."

As Dr Robert Beck discovered that the brainwaves of Shamans synchronized with the so called "earth brainwave" of the planet of around 7.83 Hz. Could it be that the higher frequency gamma brainwaves of many minds collectively together interfaced into the planetary matrix with crystals could influence the "earth's brainwave" known as the Schumann resonance and cause it to momentarily spike higher in frequency?

Jen Han: Of course it does!

On June 12th 2022 Elena and Dan did a youtube video with approximately 1700 live participates with their crystals to simultaneously imprint a vision of a positive timeline into the planetary matrix and a spike was recorded on the earth's Schumann resonance. Do you think it is feasible that this spike was a result of this collective group effort?

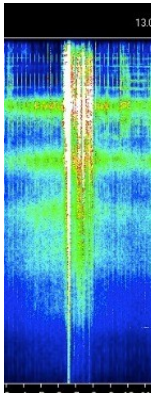

Jen Han: Of course it had an effect. There is a ratio of population that needs to be gathered to produce a visible disturbance, and you did it that day. The brainwaves emitted by all living creatures on this planet are in inter-resonance with the ionosphere shell. If this ionosphere resonance shall change, all life on this planet would be affected. This is a topic I affectionate particularly because it is part of my work. Of course this process occurs naturally as well in the universe, as a natural law. When we make worlds suitable for receiving conscious life, we construct a series of layers around the planet, that we embed in its grid. Once it is integrated, it cannot go. All is held together with frequencies. All is inter-resonant. One tingle on the web ripples to the other side at a particle level. One affects the other: when your consciousness evolves, the frequency of your planet raises. That is how the inhabitants of a world can shift the density of their planet by themselves, by the simple power of their minds. Are you getting more clarity now?

## Jen Han Eredyon Session – 09-26-2022

### Dan Comments 09-26-2022:

1) Clarification about the multi-faceted Vogel healing crystals that magnify as you say the "radiance". What is the difference between "radiance" and "Phryll" or what Marcel said the multi-faceted crystal magnified the "Prana"?

**Reference to below answer:**

Does increasing the number of facets of a multi-faceted Vogel crystal yield greater amplification as Dr Marcel Vogel assumed?

**Jen Han: No. It will magnify the healing power by radiance, the crystals that are multifaceted to an extreme are transmitting life energy by radiance but they are not the most effective when opening the eye of the crystal, because the dynamics is lost. You need to respect the structure of the lattice, and always cut in perfect ratio with its hexagonal core structure. The efficient shape of these crystals do not only concern the correct degree of the two pyramidal extremities, but as well the lateral ratio: the facets. Everything must be in harmony with the core lattice. Vertically, and laterally.**

2) Is there any advantage in the Vogel healing procedure of using a multi-faceted Vogel crystal over that of a 6 sided Vogel with 51.84 and 60.00 terminations that is cut in alignment with the natural hexagonal core lattice of the crystal?

In other words, it sounds like a properly cut 6-sided can do everything a 12 or 24 sided can do, plus more, since it can also access the eye of the crystal for other work. So would this be a preferred “healing crystal” of choice be able to do anything that a multi-faceted Vogel could do in healing work?

I ask this because a lot of Terrans think they need the extra work and expense to create a multi-faceted Vogel for healing work, whereas a 6 sided cut with the lattice structure could possibly work just as well.

**Jen Han: Every crystal work for healing, whatever the shape, because quartz does what quartz does: it realigns the atoms in an ordered state of matter, then transcends it. When you use a quartz that is cut following its lattice, it becomes a precise, powerful surgical tool. As I said previously, the 6 sided ones are the most efficient for most of the work. A greater number of sides works for healing only, because it is not about the shape anymore, but about the very nature of quartz. That is why I previously told you that the Vogel cut crystals were more efficient at 6 sides, for everything, but the greater number of sides only work for healing. And clairvoyance as well. Not because its shape anymore, but because of the properties of quartz. It will always be better than raw quartz, but when there are so many sides that it becomes a faceted cylinder, there is no point.**

**Dan Comment:**

**I could be wrong, but I get the impression that Jen Han wishes to be diplomatic in answering this question to respect all of the Terrans who have invested heavily into a Vogel multi-faceted crystals for healing and not seed a limitation thought form in association with the abilities of their investment. I can respect that. As Jen Han says about the multi-faceted Vogel beyond 6 sides “it’s not about shape anymore, but about the very nature of quartz” alluding to the multi-faceting is not serving a greater function other than what the quartz material itself provides, yet it is still more effective due to the Vogel cut versus a natural raw crystal. So my conclusion based on how Jen Han answered this is, if you were to choose a Vogel cut crystal, the most efficient appears to be a 6 sided cut in alignment with it’s hexagonal core.**

Note that Vogel crystal cutters only take into consideration the alignment of the c-axis with the points and the 52/60 degree terminations. They do not normally take in consideration that a 6 sides are cut in alignment with it's hexagonal core unless specified.

**Jen Han: Can I speak freely? Well, it is not worth investing more currency (money) into a greatly faceted crystal, a 4, 6, 8 and 12 matter. The more efficient is 6 sided. You will always have a more powerful effect when the crystal is cut following the C-axis, but it is best using the numbers I gave you.**

3) Jen Han you have previously stated that for these smaller hand held crystals for the sender angle to be EXACTLY 60.00 degrees. What if it is off 2 degrees such as 62 degrees? Why is 60 degrees chosen?

I asked this because in measuring the angle of inclination by our crystal cutter it measured 62 degrees.

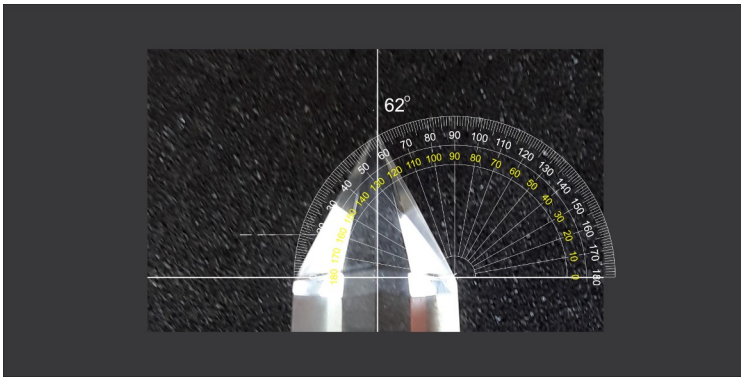

Would this 2 degree difference not being exactly 60 degrees, make a difference in opening the singularity vortex in our setup using silver electrodes with our signal generators?

**Jen Han: It works. 2 degrees difference is not affecting the singularity.**

**Dan Comment:**

I asked this question because there must have been a reason why Jen Han previously stated for the smaller Vogel crystals to be “exactly” 60.0 degrees. So the exactness of this angle apparently isn't critical in this application to affect the singularity. Wondering what application Jen Han was referring to where it needed to be “exactly” 60 degrees?

**Jen Han: you need to have 60 degree angle for the small crystals. For the greater ones, such as the crystals in the generator rooms, 2 degrees variation do not matter.**

The question about “why 60 degrees” was not addressed. My speculation as to why this angle is chosen may be due to the angular resonance of the tetrahedral fractal geometry of the holographic matrix, since the fundamental building block of this matrix is the tetrahedron whose internal angles are all 60 degrees.

**Jen Han: The sender angle must be in resonance with the geometry of the holographic matrix that is the receiver.**

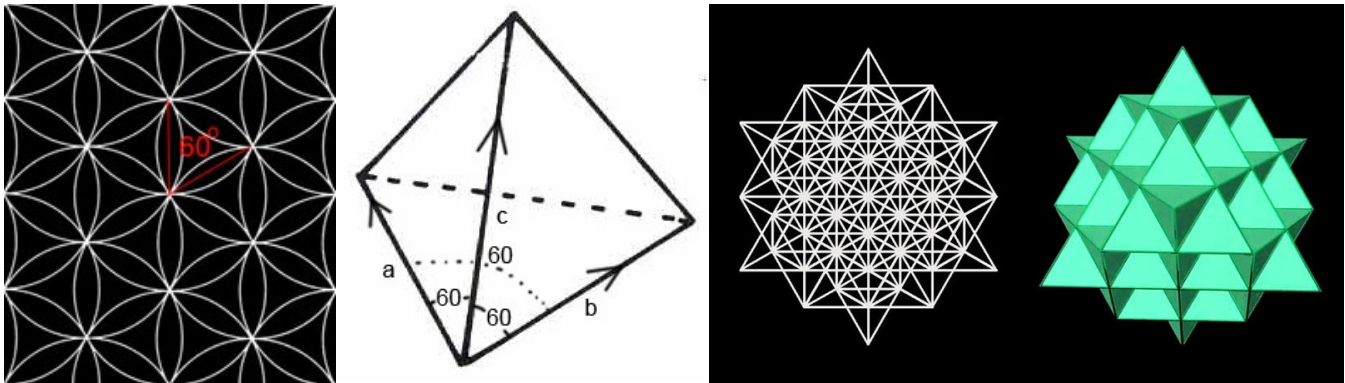

4) The following is a multiple part question on the preferred physical formation of the crystal.

In the crystal geometry formation, we have considered both of the end terminations angles of inclination to be 51.843 and 60.000 degrees with the tips aligned perfectly with the C-axis and laterally the 6 facet sides to match the natural hexagonal core structure of the crystal it is formed from.

A) What has not been addressed is the preferred width to length ratio of the crystal. What should that be?

**Jen Han: This is all about harmonics, my friend. The angles of the points matter, this is what will determine the singularity. It is best, in order to obtain a maximum power, to have the same ratio as the pyramid in Giza, on Terra. The biggest one. It gives you equations for the ratios. That machine is perfect. This monument archived a mathematical heritage to be decrypted when you are ready, and able to understand it.**

**Dan Comment:**

**I understand the importance of the 51.843 degree angle matching that of the pyramid in Giza for one of the termination angles, but if only the points matter, then if I understand correctly, it does not make any difference the width to length ratio other than the capacity of the crystal if it is long or short as in the below illustration?**

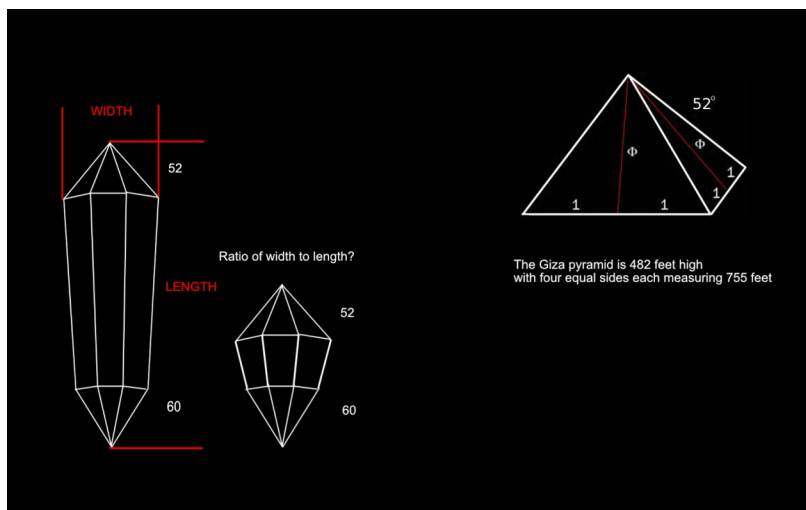

**Jen Han: it doesn't matter but you NEED (he insisted) to have a shaft that allows the vortex to occur.**

**B)** Should the sides have a tapering from the transponder end (52 deg) to the sender end (60 deg) or should there be no tapering and all the sides be straight and vertical? Or does it matter?

**Jen Han: All works, it doesn't affect the vortex. When you increase the tapering towards the sender end, you induce an acceleration in the piezoelectric currents. The perfectly straight and vertical crystals have a beauty of their own, they are fascinating. Don't you think? I find they have great power in stabilizing the currents. They can reflect and mirror reality. They have a beautiful stillness to them.**

**Dan Comment:**

**So the tapering or not is not critical for the vortex. Other than the tapering causing an acceleration of the piezoelectric currents, it seems it would be desirable to have the sides straight and vertical as is naturally formed by nature to stabilize the currents as you said.**

**Jen Han: It depends on what one wants to do with the crystals. The tapering accelerates the electric flux and it is a good tool to project Phryll, into a healing operation on a body for example. Not necessary when working with the vortex to alter the hologram. Tapering or not, doesn't matter in this last case. Straight sides are mirror crystals. They reflect and amplify any thought you place in it. They are also good for storage. The fields are stabilized.**

**C)** Is there a preferred size in length of the crystal? i.e. 15 cm or so? Does the size matter? In other words, would a 5 cm size crystal work as effectively as a 15 cm size crystal

**Jen Han: You know, when the proportions are perfect, it will work no matter the size, but the greater the size, the more Phryll it can harvest and transpond. It is a question of capacity.**

**Dan Comment:**

**Understood that it is only the capacity that is effected.**

**Jen Han: Yes.**

**D)** Is it preferred that the crystal be 100% clear of any inclusions? Will a few small inclusions affect the performance? If a few inclusions are permitted, what areas of the crystal should they be avoided?

**Jen Han: Oh avoid the vortex area. Inclusions have their own signature frequency. It alters the pure nature of quartz. It gives to them a flavor, if you prefer. You don't want that.**

**Dan Comment:**

**I was concerned about that, as my crystal does have an inclusion near the tip of the 52 degree angle termination as in the photo. I don't believe Elena's does, only in the body of her crystal which is less significant as it does not affect the vortex forming area.**



**Jen Han: Is this a quartz inclusion? So it has the same frequency as the host crystal and it doesn't disturb the flux. If it was a different material it would be annoying. But it doesn't seem it is. Also, it is not anywhere near the vortex zone so I think your crystal is good, Dan.**

Based on the answers to the above 4 part question, and any other considerations you can think of that we may have missed, we will then be able to give our crystal cutter the exact specifics in order to optimally cut and form a crystal.

5) Reference Jen Han said:

*" You can harvest Phryll by yourself, in a more natural and safer way. Your DNA is composed of micro vortices, that you can activate with your consciousness. I can show you how to do this, it is simple but it requires a lot of practice. Once you complete this training, you can feed from Phryll and you need little food."*

Jen Han, Elena and I would love to know how to do this! Can this be enhanced using our crystals with our signal generators creating an aura of Phryll around our crystals to feed from?

**Jen Han: I will show you, but not tonight. Soon.**

**Dan Comment:**

**So grateful to you for sharing that knowledge! We look forward!**

**Jen Han:I will show you soon, but also others can if I cannot.**

6) On September 12<sup>th</sup> Elena and I for the first time activated our crystals by turning on our signal generators. In the excitement, we didn't notice that the output power was not engaged, so we were thinking the silver electrodes were powered up, but they were not. Never the less, we felt a subtle effect of energy coming off the top of the crystal. Embarrassingly, after several minutes attempting to connect our consciousness into the eye of our crystals by sensing it, we noticed the crystal wasn't being powered.

Upon powering the silver electrodes on the crystal, I personally didn't feel or sense any significant change than when it was not powered. It very well may be that my sensitivity or gamma brainwave level was not at the level to be able to sense the vortex singularity of the crystal. Maybe this takes greater practice in sensing it.

**Jen Han: no need, my brother sent me the recording of your experiment. It went according to what we expected. I wanted you to experience the power of consciousness. This is something we are not supposed to tell you. You need to discover it by yourselves. "Remember". That is what I may say. The settings with your silver coins and the device work. It opens the vortex. But what works above all is the secret element you discovered: consciousness. This is the secret that was kept. Consciousness is carried on the vessel of brainwaves, just as it can be carried by the breath. That is why I told you to produce Gamma brainwaves, because it is the only way your consciousness can affect the Ether and the holographic matrix. When you focused your thoughts into the crystal you used Gamma brain waves to imprint your thoughts and desires into the matrix of reality. Yes, there are not much measurable difference because consciousness does the work.**

**Although, when you pulse an electric signal into the vortex of the crystal, longitudinal waves are generated by the pulses of the crystal. These compression waves affect the fabric of space time. Harvested, they are a tremendous power supply. In our pyramid generators, the central crystal receives the electrical pulses that will induce the crystal to generate these waves of energy. This pulsating, compression waves that are created, are harvested by the upper part of the generator. That is the top part of the pyramid. The angle is near 52 degrees. One degree variation can safely occur. This is why the receiver in your Vogel crystal has that same angle. Do you understand now? By nature of its cut, the Vogel crystal generates Phryll via the activation of the vortex, which procedure is performed via pulsation. Breath, electrical impulse, sound frequency, for the most commonly used. the receiver angle harvests it, and sends it to the emitter angle. It follows the movements in the toroidal field of the crystal.**

**Longitudinal waves are able to interact with consciousness, because the brain is an emitter and receiver of longitudinal waves. Longitudinal waves are the direct link with consciousness. So now you know, what the power of consciousness is. Coupled with the settings I guided you to build, you give consciousness a physical device to change the world as it pleases you. This great power, it is now time you know it. Experience it, but be mindful. Many predators are still on your planet. Do not attempt to commercialize it for the moment. Keep it private. Train, practice, improve it. Wait for the right moment, when shadows have been cleared.**

**There is much more we need to talk about. Elena cannot withstand a communicate for too long, we will resume our conversation soon. I am residing in your star system for a while. I am not far.**

**Be safe, friend.**

## Jen Han Eredyon Session – 2022

**Dan Comment:**

So you have confirmed that there is no problem with our equipment setup, and it is functioning according to Thor Han's recording of our experiment, showing that both Elena and my setup are indeed effectively opening the vortex when powered on.

**Jen Han: correct**

I remembered you once said...

*"If you do not feel it with your mind, you are not connected to the crystal's central vortex. You need to have the connection if you want to imprint an intention into the planetary matrix. The new template of reality cannot bridge to the old, otherwise."*

I was unable to "feel" it when the crystal was powered on, which may have to do with my need to further develop my abilities in the gamma brainwave level.

So even though I may not "feel" the singularity within the vortex, can I to some degree effectively imprint a vision into the matrix? Because I understood that if I don't feel it, I am not connected to the eye of the vortex in order to imprint.

**Jen Han: no, it works, the vortex is activated, but when you don't "feel" it, that means you are very weakly connected to it. Tiredness and low energy can affect the experience.**

Understand fully about the dark predators. I have no profiteering interest in commercializing the knowledge of this technology. My first priority is to assist in the positive transformation of Terra's timeline and work with others to do the same, as until the dark elements are no longer active on our planet, as until then, these technologies and the individuals working with them can be endangered I agree with you.

The other applications with this crystal technology that I would love to see put into application, besides healing our planet, is for healing and regeneration of our Terran envelopes and then how the Phryll might be used to enhance plant growth for agriculture for healthy robust plants.

**Jen Han: Dear Dan, you can program crystals. It especially works when you imprint the programming while the vortex is open. The program will not wither in time if it was imprinted into the open vortex. If the program is not imprinted into the vortex, so the programming will wither with time.**

Once the dark elements have been fully removed from Terra, then things like power generation would be much safer to explore, as much as I would love to do that.

Extremely grateful for all your communications Jen Han. Thank you dear friend, I'm sure you have plenty to do besides answering questions from the people of Terra. We greatly appreciate your time in answering all our questions.

**Jen Han: my pleasure, my Terran friend. I hope we meet some day.**

## Jen Han Eredyon Session – 2022

With the consideration of the exact angles  $60.00 / 51.84$  aligned with the C-axis and the very important hexagonal core alignment. The sides are shorter and straight rather than tapered and long. The ratio of the sides could be 1:1.618 (Phi for aesthetics?) or even 1:1 or ? The idea behind this is giving the two vortex forming terminations a larger area to form larger vortexes, instead of a longer crystal with smaller size terminations at the ends.

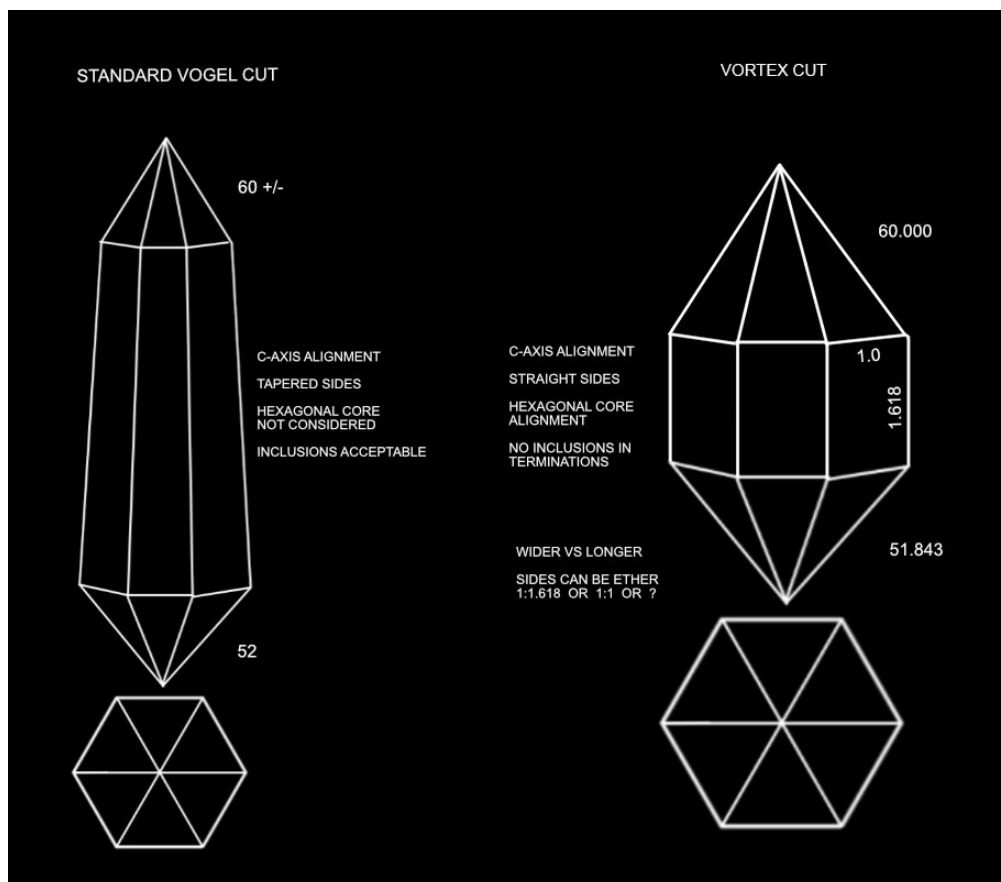

**Jen Han:** The shorter crystal will not produce Phryll, or very weakly, but it will be good with the work using the vortex, working on the holographic grid. As good as the longer crystals.

The size of the crystal will be similar so the "capacity" as Jen Han mentioned, would also be similar.

Again, based on what I've derived from Jen Han's statements this is a starting concept in moving towards in optimizing the crystal's formation

**In our last communication with Jen Han he said...**

**"Breath, electrical impulse, sound frequency, for the most commonly used. the receiver angle harvests it, and sends it to the emitter angle."**

**Wondering if Jen Han is suggesting that we could also augment our setup with a particular sound frequency?**

**Jen Han: My scale of frequencies differs from that used on planet Terra. We do not use the same scale of time so the numbers for the frequencies are different. Although, yes, you can broadcast sound frequencies. I will need to convert into your time scale.**

**Elena: Is the tuning fork called "crystal activator" 4096 Hertz useful in that regard?**

**Jen Han: I will need to verify.**

**Elena: I will try it next time when performing the experiment, and see if there is a noticeable difference.**

**He also said...**

**"Do not attempt to commercialize it for the moment. Keep it private. Train, practice, improve it. Wait for the right moment, when shadows have been cleared."**

**Jen Han: What you shall not disclose is how to produce Phryll as a source of energy with a crystal. It would be useful for humans of Terra but not for you. It could challenge your safety. This is taken care of. I was told that the mission you have chosen consists in teaching the Terrans how they can change their reality. You always knew this. Teach them how to activate the vortex, and how to modify the holographic matrix. In any case, there is a component that is kept secret when it comes to produce Phryll energy. As you may know, Phryll is akin to gravity waves. It is available everywhere on and near this planet, stars, and any object that induces gravity. Electrical pulses through the vortex of the crystal emit gravity waves. These waves carry Phryll but it is not noticeable until you interface these waves with a conductive body, object, material, planet or else. It passes through it and you can measure it. For Phryll to be harvested directly from gravity waves, you need the hidden element.**

**In regards to keeping it private. I have been sharing all of our information openly with the public. Is this something I should cease doing or limit what is shared?**

**Jen Han: I answered this just now.**

**Can dark elements use this knowledge potentially in nefarious ways, or are there safeguards in place? I will honor whatever Thor Han and Jen Han suggest.**

**Jen Han: They could use it for nefarious ends that is exactly what I meant. You don't want a second Atlantis disaster. You have lived there, you were there, you know.**

## Jen Han Eredyon Session – 11-01-2022

Hello again Jen Han my dear Pleiadian friend,

Once again, thank you for the all of the knowledge you have shared with us that has helped connect together more clearly many elements. Especially thank you for your direction on the construction of our crystal devices that will allow us to more effectively affect Terra's planetary matrix toward a positive timeline. It is an invaluable tool you have given us!

I continue to work on developing both a level of gamma brainwaves and sensitivity in connecting to the eye within the crystal's singularity vortex in order to effectively imprint into the matrix. I do this only when feeling inspired and are able to create a clear image of a positive timeline formed in my mind's eye in order to pulse and project it clearly into singularity vortex, along with a feeling of love for all beings. I know I need more development and any further suggestions are always appreciated to help move our timeline into the beautiful new reality that is unfolding for Terra that is free from the shadow elements.

Questions:

1) I would like to finalize thoughts on the optimal formation of the crystal's width/length ratio

For the purpose of creating the vortex as well as the generation of Phryll using crystals with straight sides to stabilize the currents verses tapering the sides. The tapered sides appear to be more useful for healing crystals to accelerate the piezoelectric current for projecting Phryll.

Since the shorter shaft of the crystal as in (C) in the below illustration will only be effective in creating the vortex but not creating Phryll, but a longer shaft will generate Phryll. What width to length ratio will optimally generate both Phryll as well as the vortex?

In other words, not too short and not too long, but optimal ratio of width to length

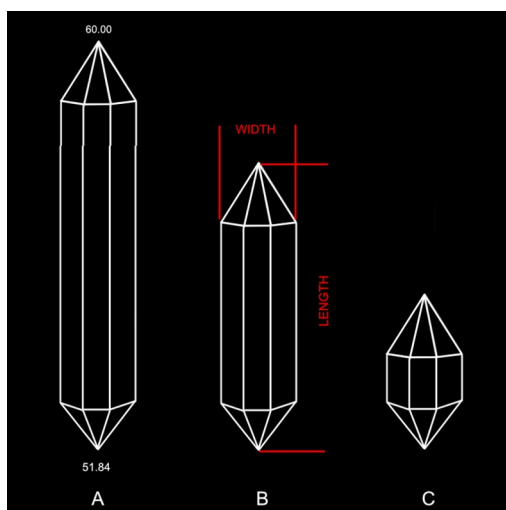

**JEN HAN:** One third of the height for the width is in general a reasonable ratio, but I have a preference for longer crystals, as you can have a good balance in the properties of the crystal. I do not have specific numbers to give. By the way, I salute you my Earth friend Daniel! It is always a pleasure to cooperate to your researches. I wish your civilization would accelerate its awakening to the truth that is still hidden from the inhabitants of this beautiful planet, by some governments. Thor Han told me you are doing a good work of defending this truth.

**ELENA:** I agree with you Jen Han, Dan is amazing and very dedicated. Are you still learning with the Seeders onboard their ships here in this star system?

**JEN HAN:** Yes I am! I study with them about the genetic building blocks of life. I made friends. I want to keep on studying with them. When I complete my certification in Starmaking of course.

**2) Why does the longer shaft permit the generation of Phryll, whereas the shorter shaft won't?**

**JEN HAN:** You want the dynamics of the piezzo-electric field to be directed upwards in order to generate a movement within the shaft of the crystal. The longer the crystal is, the faster the Phryll will circulate and in consequence, more powerful will be the energy created. It is a matter of debit. From bottom to top.

**3) As we conclude this discussion for the optimal crystal formation, is there any other factors that we did not cover that you feel are important to note?**

**Based on this information, if we wish to produce another crystal we will be able to use these specifications as a guide for the crystal cutter for it's optimal formation.**

**JEN HAN:** I believe I told everything you needed to know.

**4) In our last communication you mentioned sound frequency...**

**"Breath, electrical impulse, sound frequency, for the most commonly used. the receiver angle harvests it, and sends it to the emitter angle."**

**Could we augment our setup with a particular sound frequency (you said you may need to convert the correct frequency to use based on our time scale) ?**

**Jen Han:** My scale of frequencies differs from that used on planet Terra. We do not use the same scale of time so the numbers for the frequencies are different. Although, yes, you can broadcast sound frequencies. I will need to convert into your time scale.

**JEN HAN:** My brother can do that now. 1496 Hertz of your scale. 644 Hertz, 587 Hertz. Chose the 1496 Hertz please. Works best, but not in direct contact with the crystal, it can breach it.

**5) When your time is available Jen Han, Elena and I would love to learn this:**

*" You can harvest Phryll by yourself, in a more natural and safer way. Your DNA is composed of micro vortices, that you can activate with your consciousness. I can show you how to do this, it is simple but it requires a lot of practice. Once you complete this training, you can feed from Phryll and you need little food."*

**Jen Han: I will show you soon, but also others can if I cannot.**

**When feeding from the Phryll. I am assuming it will assist regeneration and help to alleviate disease and deterioration of our Terran envelops?**

**JEN HAN: It does. All is about reconnecting the Hydrogen links between the chromosomes' intra elements. This is a question that is exciting, because I am learning this onboard the Intergalactic Confederation ships. DNA can be transmuted into a stable state of auto-regeneration, once you unlock the blocks that keep the strands disconnected from the morphogenetic field of the universe. Longitudinal frequencies can do this, but your mind also can. If you know how to harvest Phryll it can reconnect these links within your body, with work and patience. Gamma brainwaves are the first step. Then once you have secured and protected your energy field, you consider your body as a crystal. Don't mind your legs, sit on the ground with your back perpendicular to it. What matters is the trunk from crotch to top of the skull. Open your lower energy wheel (chakra) and create an electro-magnetic current that will flow upwards. When the current meets with the central vortex (heart), it will activate it. It is by this vortex that Phryll enters. Work your breath just as you do for a crystal: short sharp pulsations, directed inwards into the heart vortex (it slightly compressed your sternum at each pulse). This harvests Phryll. Visualizing increases the result. As the dynamics of the elctro-magnetic current already flows upwards through your energy centers, it will drive the flow of Phryll and Phryll will start to enter also via your lower base center (root chakra). I tell you why, as I just said that Phryll only enters through the heart central vortex: because when the Phryll is harvested by the heart vortex, it will be caught by the elctro-magnetic dynamics flowing upwards and it will adopt the dynamics of your human natural electro magnetic toroid field. As such:**

**Heart vortex>>> upwards>>> out through top of the skull>>> cascading down on the sides following the toroidal field construct>>>re-entering through the base energy vortex>>> up again...**

**You build up your energy and you become a generator. Because you are not a crystal, you do not saturate harmfully because nature is great: the excess of Phryll will be spread out into the Aether. Unless you want to harvest it into a device.**

**The hydrogen bonds will be re-paired. Do it regularly to obtain results.**

**6) Our primary interest has been to affect positively the timeline of Terra's planetary matrix. This is a priority, as I sense a beautiful incredible future is awaiting once Terra is liberated from the dark elements that have withheld this future using secrecy and deception. So this has to happen first before much more can be released.**

**Again, so grateful for this tool you have given Elena and I to imprint a reality into the matrix. I will continue to work with Elena and teach the public online with the collective power of a group of minds using their crystals. (more of the public are purchasing Vogel type crystals for this work)**

Our other two interests is using crystals are for our body health and also if there is a way to accelerate the grow of plants for food by feeding them Phryll. Let us know if you have any suggestions in ether of those important secondary areas.

I am with you dear friend, I too don't want an Atlantis replay. You said "You have lived there, you were there, you know." I was not aware of my past Atlantean life, do you have the ability to view that past life of mine is why you said that?

JEN HAN: Dear friend, I do have this ability because we have devices that are able to read the consciousness field. I cannot do it with my mind only because I would need to connect directly with you and ask for your permission. Also, Thor Han tells me that you need to remember by yourself in order to reactivate certain parts of your consciousness. I am not allowed to say more, only that you were a scientist and attendant of one of the generators. Your field of expertise included medical holographic science. You were there at the end and you left before the great disaster, as you were part of the teams who traveled either side of the ocean to concealed the knowledge and technology deep underground in secret places. I must not say more, at least for now. I hope my questions were satisfying, please, do not hesitate to continue this pleasant adventure together.

Your friend from afar.

## **Jen Han Eredyon Session – 12-2022**

**Hello again Jen Han my dear friend from afar,**

**Wish to express gratitude to your older brother Thor Han, to allow these communications to occur, and for helping us Terrans to liberate our planet. I salute you for taking on this task.**

**Jen Han, I greatly appreciated you helping me understand my ancient past in our last communication with my involvement with the science of crystals during the time of Atlantis. This explains my interest possibly stemming from my soul's memory.**

**You have greatly contributed to our understanding these sciences which Elena and I are sharing with the Terrans to assist the liberation of our planet with these tools using our consciousness. I know we have a long ways to go, but your knowledge has helped us to begin to bridge this understanding.**

**Elena and I have been doing the exercises you shared to transmute our DNA into a stable state of auto-regeneration and we are both experimenting with little variations of the exercise.**

**During the exercise I activate my crystal for the Phryll to emanate from the vortex to fill the environment and I am augmenting the portal opening with the sound frequencies Thor Han gave from a speaker about 12 inches from the crystal.**

**Should I only do a constant 1496 Hz? or would it be alright to sequence the three frequencies repeatedly 587 Hz, 644 Hz and 1496 Hz ?**

**JH: Well first my dear friend from Terra, I want to salute you for your ongoing efforts to bring knowledge and liberation to the Humans of Terra. This beautiful planet. You know, the scientists of the Intergalactic Confederation worked relentlessly to assist this planet that it develops a great variety of life forms without too much interruptions and obstacles. You may say that obstacles are of assistance for our evolution, but there are two kinds of obstacles: those that make you grow and those that stop the growth. In any ways, I am learning a lot in science, and universal consciousness and laws, onboard the Altean ship. I am having good time. I will be a great starmaker! I am glad that you are enjoying the training and that you are maintaining your body avatar in good shape. Aging comes by levels, doesn't it. It comes by temporal waves. All you have to do is diminish their impact. Your genome was altered as you know, and this practice of harvesting Phryll is helping your genetic sequences to re-bind their broken links. You are asking me if you must pulse a constant 1496 Hz, it is not necessary. It is best to pulse for a few seconds and then let the particles adjust their rate, then do it again after a while. Feel the particles telling you when they are craving for more of this frequency. You can also sequence the three frequencies and play this sequence intermittently. I hope this makes sense to you.**

Questions:

1) General questions

On your planet when you form crystals, do you mine the crystals that grow naturally within planets like we do on Terra? Or do you grow the crystals and then form the terminations for the purpose of the crystal?

JH: Crystals are mined everywhere in the universe, when it does not disturb an environment. When you take crystals off an environment, the frequency of this environment changes slightly. So more commonly we grow them in our making-places. The growth does not include artificial ingredients; the growth is natural, simulated by frequencies. I know that you are going to ask me for these frequencies, but it comes with holographic devices so I cannot help here.

Does extracting the planet's crystal deposits have any determinant effect on the planet, or is it minimal?

JH: I just answered this.

I am assuming clear quartz is the common crystalline element you use for most of your crystals?

JH: Yes, of course, clear transparent quartz is the most elevated state of solid matter in this universe! It is the purest.

Do you use small hand held crystals like Elena and I are using, do they use the same specifications you have given and how do you use them?

JH: I do not understand your complete idea in asking this question. Myself, if you are asking about myself, I love playing with small crystals that hold in the palm of my hand. I levitate them and I make them sing. It is enjoyable, very much.

E: Jen Han you told us that it is dangerous to make a crystal sing?...

JH: (laughs) not THAT singing! Not with an electrical pulse going through it. I make them sing with my mind.

E: How do you do that?

JH: A few millennia of biological evolution and an Ahel brain (laughs)

E: Can an Earth Human do it?

JH: Yes, with practice.

E: So... how can I do that, with my Earth-Human avatar retarded brain?

JH: (laughs) Sing your frequency through it. That is all I can say. You need to find out and, remember how you used to do it, when you occupied an Ahel more advanced avatar. Your intuition will unlock this ability, which has imprinted your soul memory.

E: Ok, I don't think Dan has ever occupied an Ahel avatar?

JH: He has, once. In the future of your timeline.

E: So he can try to remember as well?

JH: Yes he can. He will have great enjoyment. It is harmless and very enjoyable. Sometimes, it creates colors.

E: Like the Nhor people do, from the Daran system?

JH: Yes.

E: Ok, next question now.

I understand some crystals, such as the "Fire Crystal" of Atlantis was massive in size and I am curious how such a large crystal was able to be obtained?

JH: It was brought from the Altean homeworld. I do not know how they produced it. I will ask.

In communication with our crystal cutter to form what we call a "Vogel/Eredyon" to note that it is cut respecting the hexagonal core so that the Terrans can have more effective tools. Besides the 6 sided alignment with the hexagonal core of the crystal, we would like to confirm the following extra details for the crystal cutter to confirm and conclude on the crystal's form.

2) Regarding the length to width ratio question. Is the width measurement measured as A or B ?

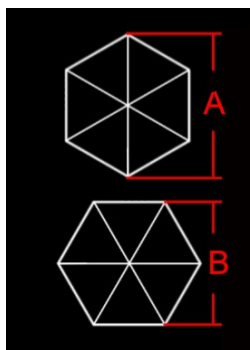

JH: B

You said a 1:3 ratio is in general a reasonable ratio, but they can be apparently longer.

*"One third of the height for the width is in general a reasonable ratio, but I have a preference for longer crystals, as you can have a good balance in the properties of the crystal. I do not have specific numbers to give."*

3) You said you have a preference for longer crystals, so I assume that the 1:3 is a general ratio and that the length to width ratio is not really that critical, as it could be any length longer, as the longer shaft crystals you say generates more Phryll. So then for Phryll generation, would it be correct to say that the 1:3 ratio to be a minimum shaft length requirement and then if the crystal has a longer shaft, that is not a problem?

*“The longer the crystal is, the faster the Phryll will circulate and in consequence, more powerful will be the energy created.”*

**JH: This is exact.**

4) Confirming that you said if there are quartz inclusions in the crystal, they should be avoided in the vortex area as shown as the red dot area

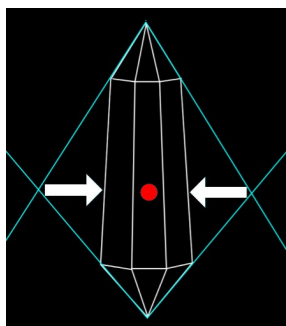

**JH: Exact. Quartz inclusions if they are quartz, do not matter, except if they are in the area of the eye. Consider a horizontal discoidal area with the vortex at the center point. This must be unaltered.**

5) Confirming that you said that tapered or straight crystals both work for the vortex, and that the tapered sides enhances the projecting of Phryll for healing operations, and the straight sides are good at storing imprinted patterns. But either are effective for healing work.

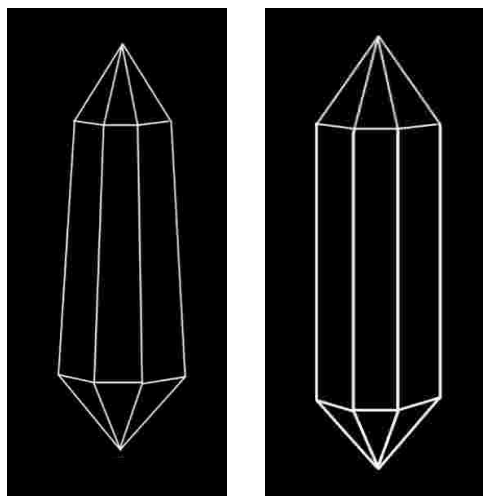

**JH: Both are effective for healing work, the tapered sides projects the Phryll as a natural dynamics, I confirm. The vortex work is equivalent for both.**

**6) I am assuming it is always preferred to have the hexagonal form to be symmetrical?**

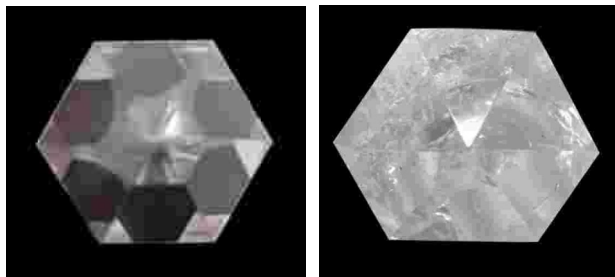

**Symmetrical**

**Asymmetrical**

**JH: Symmetrical. The second picture works also but chose Symmetrical for the best performance.**

**7) The exact termination angles of 51.843 and 60.000 can have what degree of error and still be effective? Such as 1 or 2 degrees of error?**

**JH: I do not know how to answer exactly, as it depends on the size of the crystal. The greater the size, the more you can vary the degrees of the angles. But not too much! Keep the ratio. You can go to 3 degrees of variation in the big crystals but for the ones that hold in the palm of your hand it is best to respect the original ratio. I do not know how to give you a rule with sizes. Keep close to the original dynamic-geometry ratio.**

**8) Dr Marcel Vogel believed for the Vogel type crystal to function properly and effectively, that the consciousness and intention of the one who is cutting the crystal is critical.**

**JH: I agree with him.**

**My thoughts are that if the crystal is cut accurately to the proper specification in respect to the lattice and being that quartz is programmable, that whatever energies were associated with the crystal during the cutting process can be effectively erased and reprogrammed to it's users intention and not affect the functionality in any way, would you agree?**

**JH: I also agree. But you know, when you cut a crystal, if the cutter imprints his high degree of consciousness, it will help the crystal to awaken. Love, is the state of mind the cutter is recommended to emit as a frequency when cutting a crystal. It is a very sacred act.**

9) In regards to the importance of first clearing a crystal you said...

*“There are methods of purification I can tell about, the best is to run the crystal through a sound scan. You need instruments that create a high frequency sound, or trained persons can clear a crystal with their own consciousness. These individuals have reached a clear state of mind. ”*

Is there a frequency we can project at the crystal to facilitate this clearing?

**JH: 4096 Hz**

Dr Marcel Vogel in his laboratory found two methods he was able to measure to clear the information stored in the crystal.

- 1) A magnetic bulk eraser (a strong magnetic field alternating at 60 times per second)
- 2) Pulsed breath with the intention to clear done with fingers on each of the opposing facets.

Marcel did not believe that the following methods were able to effectively clear the crystal. Do you concur?

**Soaking in salt water**

**JH: It does not remove a programming. It cleanses low frequency imprints such as low emotional charges. Or stress due to the cutting and handling.**

**Exposing to moonlight**

**JH: It does not remove a programming. It cleanses same as above.**

**Smudging with sage**

**JH: It does not remove a programming. I do not know the properties of this herb but my guess is that it may only cleanse the aura of the crystal. Not inside. Smoke doesn't go inside of a crystal. Nor water, nor salt and so on. Only sound, light, consciousness, vibrations, magnetic fields and electrical pulses can go through a crystal, so it can properly cleanse and deprogram a crystal.**

**Exposing to sunlight**

**JH: It does not remove a programming. Sun radiations nourish the crystal and the crystal harvests Phryll from the sun when activated. Photonic light clears impurities in a crystal. Light also goes through it. Because a quartz crystal is solid light.**

**Burying them in the ground**

**JH: It does not remove a programming (laughs). I don't know what it cleanses but this may be related to what you call on Terra “magic” rites. I believe the magnetism of the planet, that activates the mineral particles present in the natural soil, can affect positively a crystal to change the electrical charge. I trust that the crystal may enjoy it. But not for too long, crystals need light. Some crystals can soak in a soil if it is too rich in iron, and tint it yellow or brown, you do not want this to happen.**

**Visualizing it is clear**

**JH: It CAN remove a programming if you put the intention of clearing it from all programming. Cleanses of course as well. Consciousness is the most powerful tool in this universe to affect the matrix of things.**

**Chanting sacred sounds**

**JH: It does not remove a programming unless the sound of the voice carries the intention above. Voice carries fractals of consciousness. Voice is a carrier that affects the matrix. Chanting without intention/ consciousness does not deprogram a crystal. It must not be a passive chant but an active chant.**

**Various Sounds i.e. bells, bowls tuning forks**

**JH: It does not remove a programming but certain frequencies cleanse crystals from low vibration imprints. 4096 Hz cleanses to purity. Coupled with conscious visualization, it removes programmings.**

**You understand: a crystal may be: unclean and not programmed. Unclean and programmed. Clean and programmed. Clean and not programmed.**

**10) All of the information you have shared should be able to give our crystal cutter all the necessary specifications to form what we are calling a Vogel/Eredyon cut crystal to differentiate it from the regular Vogel cut crystals that do not necessary align with the hexagonal core of the crystal. Is there any final considerations that you can think of to pass along to the crystal cutter as we conclude the details on the crystal formation?**

**JH: not that I can think of. It has been a real pleasure to communicate again with you! Elena was reconstituting your voice in her mind as she read the text, so it was as if I was talking to you directly. Amusing game! I hope to do this again soon. It is a real enjoyment.**

**Again, thank you my dear friend from afar!**

**Be well my friend from not-so-far Terra.  
Jen Han.**

## Jen Han Eredyon Session – 01-2023

Dear Elena

So you and I accomplished a lot with Jen Han getting all those details on the crystal formation finally confirmed. Now that that is completed. A very important aspect to address in the use of the crystal, which both Jen Han and Marcel stressed as being critical, is effectively clearing the crystal of previous imprints.

Jen Han said:

*“...beware, the crystal must be empty. This means: no residual emotional imprint, parasiting or charge. The crystal must be pure and clear from any form of energy, or consciousness even. I wouldn't say that at this stage, the crystal is really "empty", because it carries its frequency imprint, but I mean empty from anything that is not the original frequency signature of the crystal. In order to perform this action: embedding a fractal of your consciousness in a dynamic projection, into the crystal, the receptacle must be pristine pure. There are methods of purification I can tell about, the best is to run the crystal through a sound scan. You need instruments that create a high frequency sound, or trained persons can clear a crystal with their own consciousness. These individuals have reached a clear state of mind.”*

From our exchanges there appears to be mainly 3 effective methods available to us Terrans to effectively clear previous programming in the crystal.

1) Pulse breath with intention:

Jen Han says this can be done by “individuals who have reached a clear state of mind”. I think you agree with me that this is a rare condition on planet Terra. Never-the-less it is what Marcel primarily used extensively and taught. He was also able to measure on a spectrophotometer with water the changes of the water structure using the pulsed breath method.

2) Magnetic Bulk Eraser:

Marcel believed that the intense fluctuating magnetic field that was originally designed to removed information from magnetic tapes, effectively removed the programming in the crystal.

Jen Han commented and said *“It sounds like it can work. Good device. I like it better with the mind.”*

3) 4096 Hz Frequency:

This method, you were the one who originally brought it up by saying...

Elena: Does a tuning fork 4096 Hz do the job?

Jen Han: Not enough. It will clear the energies but not the emotional imprints.

Elena: What do you call the emotional imprints and how to clear them?

Jen Han: I have a device that does that but I cannot show it to you, I am sorry.

In our last exchange I ask about the use of various sounds to clear the crystal  
Jen Han said: *“4096 Hz cleanses to purity. Coupled with conscious visualization, it removes programmings.”*

Considering not everyone has a clear state of mind for pulsed breath method or has a magnetic bulk eraser, but 4096 Hz tuning forks are easily accessible and very inexpensive. It would be good to get clarity on this one method since clearing is critically important in this crystal work.

Jen Han originally said the 4096 Hz does not remove the “emotional imprints”. The question would be is this essentially important to remove and is there a way the Terrans can remove them?

Jen Han:

Do not underestimate the power of consciousness. It is the most powerful tool in the Universe. The wind of consciousness brushing through a crystal clears everything that doesn't belong to its original frequency structure. It clears also emotional imprints. Consciousness is the best tool you can find. All sentient beings are able to use that power. You only need to harness it. This is obtained by training. From the center of your being, in a dynamic expansion of your field of consciousness, use the visualization of a wave of pure bright light clearing the crystal. Everything is cleared.

Regarding the device you name Bulk Eraser, it is working well, I know now what this device is. But always use the dynamic field of Consciousness, always at the same time for any work you may do with crystals.

The emotional field, you ask. Conscious visualization using your mind's electric field will be the best method to employ. The Bulk Eraser device may do well, but better couple it with consciousness.

The 4096 tuning fork is a good tool, also here coupled with conscious visualization. I do not recommend that you interface physically a crystal with an electrical pulse device on the 4096 Hz frequency, it may damage the crystal. Consider these options: The sound frequency must come as a wave brushing through the crystal, to clear the programmings and intrusions, it arrives from one side and pushes the intrusions out of the crystal on the other side. If you touch the crystal physically with the tuning fork, the sound wave will not brush through but it will shake the whole crystal that will vibrate equally to all directions in space, sending out a 4096 Hz signal and it doesn't give the best results.

Also, is the application of the 4096 Hz to the crystal most effective through the use of a tuning fork and the recommended method of applying this to the crystal coupled with conscious visualization? This appears to be the simplest method.

Sound vibrations emanating from a speaker :

The speaker must be perfectly operational without any sound interference-dissonance. Yes, but not the best method.

Electromagnetically through a coil using a pulsed or sine-wave signal:

Yes, it will clear it, but be careful as you will produce a type of Phryll that is of a high substance. I cannot disclose more about this for now. May I guess that you remember this technics from Atlantis? You know it works. It not only clears everything but it produces something that was sought after by those who used to run this planet. It is safe, 4096 pulse will not shatter the crystal in reason of the coil. The coil drives the pulse's dynamics outside of the crystal. Do not let it sing.

Direct electrical contact on the sides of the crystal using a pulsed or sine-wave signal:

Not with the silver disks. As I explained earlier, it doesn't drive the sound wave outside but the crystal absorbs the pulse and for this frequency it is too much.

Jen Han originaly said:

*“There are methods of purification I can tell about, the best is to run the crystal through a sound scan.”*

Can the technical details on how to produce and run a “Sound Scan” be shared?

Jen Han:

It is a device that we have, I do not not have clearance to share with you its technology. It infringes on another department.

In conclusion, as you ask me, You can perform a crystal clearance with always coupling with conscious visualization. With these tools: Bulk Eraser Device, tuning fork 4096, silver or copper coil using electrical pulse wrapped around the crystal not for very long. You will feel it, when the crystal is cleared, as an expansion of its presence. Suddenly, you will be aware that it is alive and it has a tangible presence.

I am very glad Daniel, that you perform the exercises I recommended. I can sense the change in your bio-field. I am still in your star system, studying with the Do (*Elena: the Seeders group*). I heard you have had difficult weather conditions where you live on Terra. This is the inconvenience to live in the bio-sphere of a planet, you get to have seasons sometimes. In a starship we enjoy a harmonious balance of temperatures and on Erra, my homeworld, we control our weather conditions. Terra is wild. Not for long.

My friendship to you, ancient one (*Elena: I understood it in the sense of “elder”*).

## Jen Han Eredyon Session – 02-2023

Dan: Clarifications requested below regarding the coil winding configurations and Phryll harvesting

My dear friend Elena

Very insightful information from Jen Han on the methods to clear the crystal from previous imprints. He clarified that both the 4096 tuning fork and the magnetic bulk eraser coupled with consciousness will perform the clearing of the crystal. In addition, Jen Han elaborated on the use of a coil to electromagnetically clear the crystal which is of interest to go into greater detail.

Reference:

Electromagnetically through a coil using a pulsed or sine-wave signal:

*Yes, it will clear it, but be careful as you will produce a type of Phryll that is of a high substance. I cannot disclose more about this for now. May I guess that you remember this technics from Atlantis? You know it works. It not only clears everything but it produces something that was sought after by those who used to run this planet. It is safe, 4096 pulse will not shatter the crystal in reason of the coil. The coil drives the pulse's dynamics outside of the crystal. Do not let it sing*

*In conclusion, as you ask me, You can perform a crystal clearance with always coupling with conscious*

*visualization. With these tools: Bulk Eraser Device, tuning fork 4096, silver or copper coil using electrical pulse wrapped around the crystal not for very long. You will feel it, when the crystal is cleared, as an expansion of its presence. Suddenly, you will be aware that it is alive and it has a tangible presence.*

My request for further clarification on this coil method:

1) Does the wire wrapped around the crystal need to be in physical contact with the crystal or can the wire be wrapped around a coil form (electromagnetically transparent) and be induced electromagnetically for clearing the crystal that can slide down over the crystal to be easily removed?

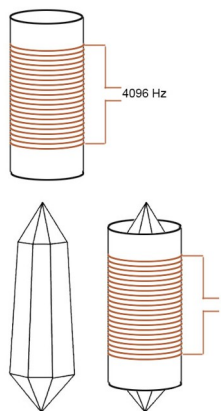

JH: It is better that the coil does not touch small crystals; the pulse could be too strong and shatter the structure. Taller crystals are able to endure direct contact with the coil but not small crystals. You will ask me this question: when I mention tall crystals it is in general about higher in size than 6 Ft. However, it is always recommended that the coil doesn't touch the crystal, it allows the piezoelectric effect to occur freely, as the oscillation of the lattice is not constrained. Also, be careful with the material you will use, better form the coil around a tube and remove the tube. You can also use electromagnetically “transparent” materials such as on your visual. Use 1 coil. Copper is best to clear the crystal.

There is another method when a silver and copper crossed double coil wraps around a crystal, this is used in the large-production Phryll generators. This is something else.

Dan: For the single coil configuration to clear the crystal with a copper coil wound “starwise” you referred previously to feed it with a 4096 “pulse”. Did you mean “sine wave” for this configuration as you recommended for the double copper/silver coil configuration?

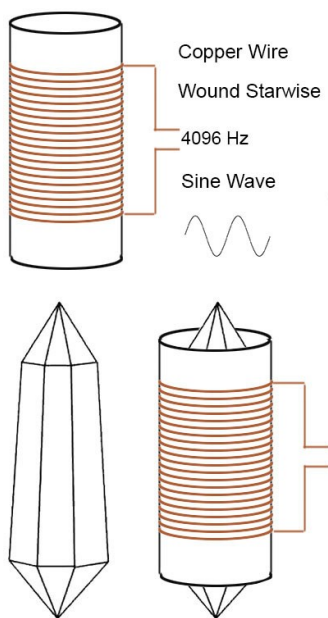

2) Does the 4096 Hz signal sent through the coil need to be a sine-wave or a narrow pulsed signal?

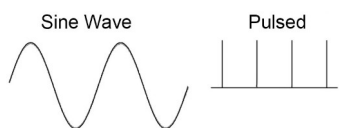

JH: To clear it: Sine-Wave

3) Would a signal amplitude of 15 to 20 volts be sufficient from our signal generators?

JH: The coil doesn't touch, so the risks are insignificant. But you must be careful not to use a power above 60 when you use a copper coil. Clearing a crystal requires no more than 20 volts. I had to check the voltage correspondence, as you know we do not use electrical voltage same as you do. It depends on the size of the crystal, the intensity of the clearing to be performed, and the personality of the crystal. Some are fragile, others very strong. You can feel that. Make sure you check for the presence of cracks in the crystals, or veins/ inclusions of other materials; these are weak points that could not end up well. In that case, reduce voltage.

Dan: Understood. Applications will be for clearing or erasing all previous imprints in the crystal before using it. Also for the generation of Phryll for healthful proposes as well as plants

4) Should the wire windings be in both clockwise and counter-clockwise directions?

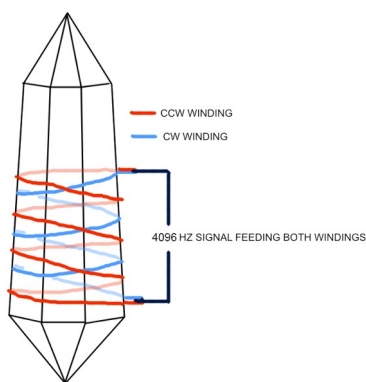

JH: here we are. Only one copper coil is enough to clear a crystal, wrapped clockwise. You know that your electromagnetic field is calibrated on the gravitational orbit of your planet around your star. That is why we do not say “clockwise” but “starwise”. I am sure Dan will like that. So I will use this term.

Using the two coils for sure will clear the crystal quicker, but it will also produce Phryll if the two coils are crossed at a 90 degree angle. It works also with a 45 degree angle but way less efficient to produce Phryll. Smoother.

If you have nothing to harvest it, the Phryll will radiate from the crystal. With small crystals it is not a big problem; the Phryll will regenerate and invigorate all living form in a radius proportional to its size. After which distance the Phryll will dissolve into the Ether. Plants love that, as I know your soulmate grows plants around you and she is very much fond of them. You can safely use a crossed double coil with small crystals. Just please, monitor the operation in case it sings. If the voltage is too high, it will.

Dan: Regarding Phryll harvesting. When the crystal is activated to radiate Phryll into the surrounding environment, is there any recommended methods to harvest that Phryll and deliver it to plants located in another area?

Such as having quartz crystals in the Phryll auric field to absorb the Phryll and then place the crystals in the soil next to the plant?

Or a container of water or even coiled tubing of water flowing around the crystal which can emanate Phryll into the water which is then used to feed the plants?

Can this Phryll be harvested using a geometrical form such as a pyramidal form and through geometrical quantum resonance transfer the Phryll to another location?

While on the topic of Phryll harvesting, I wanted to comment on the wonderful exercise to regenerate our DNA that you shared which can help in regenerating our Terran envelops. You shared that this exercise helps to “reconnect the hydrogen links between the chromosomes' intra elements. DNA can be transmuted into a stable state of auto-regeneration once you unlock the blocks that keep the strands disconnected from the morphogenetic field of the universe.” I do feel very energized after doing it.

I wanted to check with you to make sure the variation of the way I am doing the exercise is effective and any suggestions you may have. Since I have an activated crystal with the 20 Hz pulses going to the silver electrodes to generate Phryll available, I do the following:

I sit in a chair and with my left hand over the top of the emitter end of the activated crystal without touching it in order to draw in Phryll through my left hand vortex, and with my right hand holding a small 6 sided Vogel/Eredyon cut crystal which I hold it with the emitter end pointing at my heart to assist in projecting the Phryll into my heart vortex with each pulsed breath with approximately every 5 Terran seconds between breath pulses. I do this while I visualize during each breath pulse that the Phryll is being fed into the heart vortex which is in turn feeding the upward toroidal energy flow from the base of my spine to the top of my head and back again recycling continuously and this flow is being fed with each breath pulse by the Phryll entering the heart vortex. I do this for a period of 3 to 5 Terran minutes duration per day. I wish to do this more regularly than I am, but first wanted to check with you on this procedure.

Dan: Is this the proper winding configuration below of the two copper and silver coils at 90 degrees that can slide down over the crystal without touching the crystal?

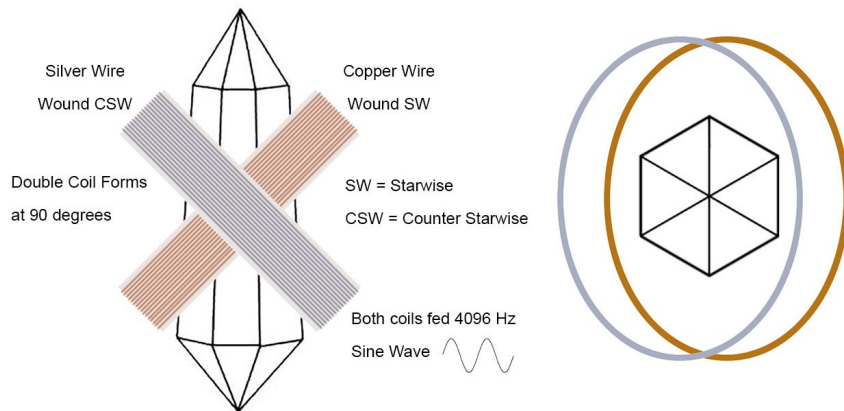

Is the Sine Wave also used in this configuration to generate Phryll? Or does that require a pulsed wave form for Phryll generation?

4) You mentioned using silver or copper wire. Are they both equality effective using one or the other? Can they be combined together where one is wound clockwise and the other counter-clockwise? If so which would be clockwise and counter-clockwise?

JH: Silver wrapped counter-starwise and copper wrapped starwise. Copper works with the electromagnetic field, silver works with the etheric field and compression waves. The crossing of the both creates energy because it generates a torsion field. If the power reaches a certain level, especially if coils are crossed at 90 degree angle, two perpendicular toroids will form and the antigravitic process will activate. The crystal will lift above its support. If when this happens, the crystal is constraint and tied up to the support, it will explode. Never mess with torsion fields, we fly starships with this technology.

Dan: I will keep the power level below 20 volts to be safe.

Dan: In Elena's book "The Seeders" she did an illustration of a crystal generator with golden and silver coil windings around the crystal. Note that I enlarged a section and inserted it for closer viewing of the double coils.

Elena described the following:

*"The Crystal Generator I was shown on a distant world. This culture uses the vibrations of sound, chanting and hitting the metallic mesh on the ground, to send impulses to the crystal coiled with golden and silver metallic threads. The Pyramid Crystal Generator I saw in the Uhurai Valley on planet Erra, in the Pleiades. The crystal is also wrapped with double coils."*

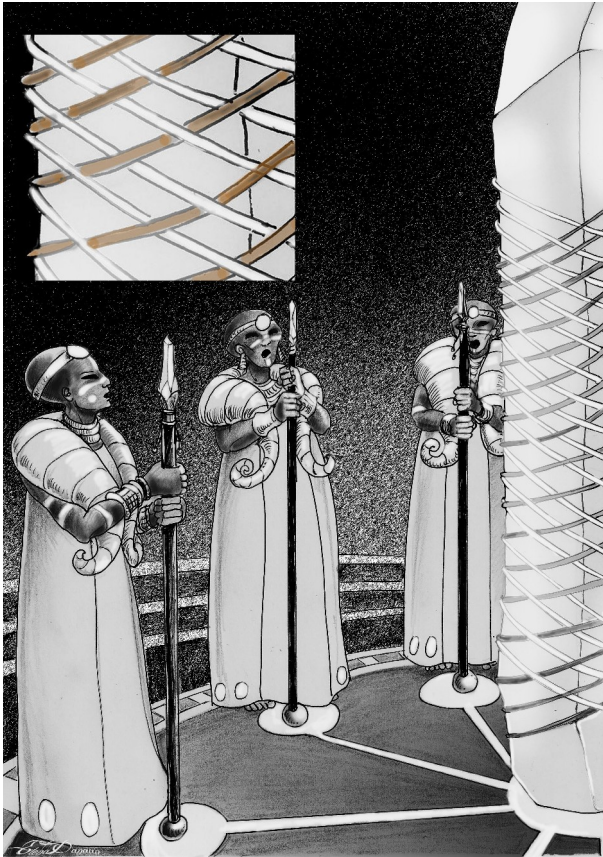
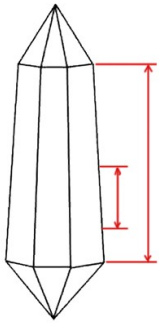

Image property of Elena Danaan from her book "The Seeders"

Dan: The coiled silver and golden (gold or copper?) windings around the crystal in Elena's illustration appear to be interwoven and at about a 45 degree angle to each other. I can see how the two windings can be wound like this to be at 45 degrees but not at 90 degrees in this particular configuration. Does this illustration relate to the correct way of winding the two coils to form the two perpendicular toroids?

5) Should the windings cover the entire length of the shaft or just in the vortex area of the crystal?



JH: There is no rule for this but always stop, above and below, a bit before the angle that delimitates the start of the 2 points of the crystal.

6) Do you recommend winding around either the crystal directly or a coil form with a high density number of turns or less density?

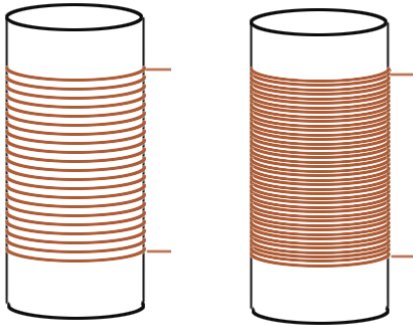

JH: It is always better when the coil do not touch itself in the winding. The denser the coil, the denser is the electromagnetic field. It can touch but it is more powerful when it doesn't.

Dan: When you refer to not having the coil touch itself in the winding, is the concern here that the electrically conductive wires would, as they say on Terra, “short out” by the electrical signal jumping over and connecting to the next wire? Or is spacing preferred between the wires for another reason why they should not touch, to be as you said “more powerful”. I ask, because the wires of both silver and copper are available to come with an insulation coating to prevent the wires from conducting to each other, so they could be wound tightly together for a denser electromagnetic field.

7) The time required you said will not take very long and that we will be able to sense that it is cleared. You also said that it is safe, but to be aware of not letting the crystal sing. So this application of 4096 Hz to the crystal may take less than one Terran minute to clear?

JH: Yes, less than a Terran minute.

8) When using the 4096 Hz tuning fork to “brush” these oscillation over the crystal, do you recommend applying the sound perpendicularly to all 3 axes of the hexagonal crystal?

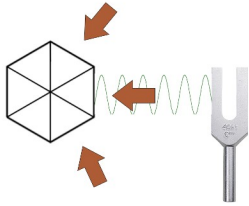

JH: yes.

As always, thank you Jen Han for clarifying these methods of clearing the crystal, as it is logically the first process to address before performing applications with the crystal. I hope some day we can meet in person my friend.

JH: Dan, my friend. I know we will, when all of this will be over. I am here and not going anywhere, so I am always ready to jump in a scoutship and come and visit you, but this is not the moment yet. One day soon, it will be. We keep in contact and I am always happy to answer your questions. It is getting more exciting each time. I have all clearance to disclose these technologies to you, now that my brother can give these clearances from the high command circle. You only have to ask questions, that is how these things work. As you know.

Much enjoyment to come.  
Your friend Jen Han Eredyon.

Dan: I have great gratitude for you and your older brother Thor Han, who I wish to congratulate for being promoted into the high command circle and whose authorization is allowing us to have these communication exchanges possible, and to your wonderful emissary and my dear friend Elena who provides the quantum communication link in order to bring this knowledge to the people of Terra. Elena and I are excited to receive this knowledge as we are planning to teach a series on crystal technology to empower the Terrans with knowledge of crystals working together with love and our creative power of consciousness to help transform our world.

Jen Han my dear friend, I greatly look forward to the day when our planet is liberated from the dark elements and that you can come and safely visit me here on Terra. Since I was a child on this planet I've always wanted to meet a being from the stars such as yourself. I know the day that happens, it will be very transformative to my current perception of reality and I greatly welcome it, as it is time the full truth to the world is known and the deceptions exposed. I have faith that our planet is indeed on a positive timeline trajectory and that and that we are about to witness an amazing transformation that will as you say bring much enjoyment to come! I look forward to when we can all celebrate together!

Thank you for your friendship Jen Han  
Your friend Dan on planet Terra

## Jen Han Eredyon Session – 03-15-2023

Dan: Clarifications requested below regarding the coil winding configurations and Phryll harvesting

Note: These questions were communicated to Jen Han by scanning them through Elena's eyes and then archived by Thor Han Eredyon to be shared with his brother Jen Han.

My dear friend Elena

Very insightful information from Jen Han on the methods to clear the crystal from previous imprints. He clarified that both the 4096 tuning fork and the magnetic bulk eraser coupled with consciousness will perform the clearing of the crystal. In addition, Jen Han elaborated on the use of a coil to electromagnetically clear the crystal which is of interest to go into greater detail.

Reference:

Electromagnetically through a coil using a pulsed or sine-wave signal:

*Yes, it will clear it, but be careful as you will produce a type of Phryll that is of a high substance. I cannot disclose more about this for now. May I guess that you remember this technics from Atlantis? You know it works. It not only clears everything but it produces something that was sought after by those who used to run this planet. It is safe, 4096 pulse will not shatter the crystal in reason of the coil. The coil drives the pulse's dynamics outside of the crystal. Do not let it sing*

*In conclusion, as you ask me, You can perform a crystal clearance with always coupling with conscious visualization. With these tools: Bulk Eraser Device, tuning fork 4096, silver or copper coil using electrical pulse wrapped around the crystal not for very long. You will feel it, when the crystal is cleared, as an expansion of its presence. Suddenly, you will be aware that it is alive and it has a tangible presence.*

My request for further clarification on this coil method:

1) Does the wire wrapped around the crystal need to be in physical contact with the crystal or can the wire be wrapped around a coil form (electromagnetically transparent) and be induced electromagnetically for clearing the crystal that can slide down over the crystal to be easily removed?

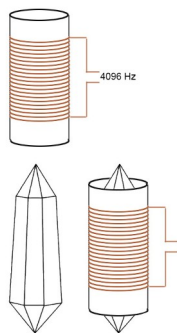

JH: It is better that the coil does not touch small crystals; the pulse could be too strong and shatter the structure. Taller crystals are able to endure direct contact with the coil but not small crystals. You will ask me this question: when I mention tall crystals it is in general about higher in size than 6 Ft. However, it is always recommended that the coil doesn't touch the crystal, it allows the piezoelectric effect to occur freely, as the oscillation of the lattice is not constrained. Also, be careful with the material you will use, better form the coil around a tube and remove the tube. You can also use electromagnetically "transparent" materials such as on your visual. Use 1 coil. Copper is best to clear the crystal.

There is another method when a silver and copper crossed double coil wraps around a crystal, this is used in the large-production Phryll generators. This is something else.

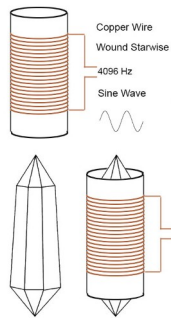

Dan: For the single coil configuration to clear the crystal with a copper coil wound "starwise" you referred previously to feed it with a 4096 "pulse". Did you mean "sine wave" for this configuration as you recommended for the double copper/silver coil configuration?

**02-15-2023**

**JH: Salutations my friend. Sine Wave is the right answer for clearing a crystal. It produces Phryll, but Pulsed signal is best for efficient Phryll production.**

**Dan: 02-17-2023 Further clarifications continued.**

**Salutations Jen Han my dear friend. I assume due to the Prime Directive, that it is required that we go back and forth with my questions and your answers in the clarification process. Since it would be a violation if you were to give a lot of detailed information on specifically how to do something without me first asking you how to do it. Is that correct?**

**JH (02-17-2023): Salutations again my friend. Yes it is correct.**

**Otherwise, we wouldn't need to ask you a myriad of questions in a process of elimination of what is correct and what is not in understanding something, such as we did for example with the correct formation of the crystal, which we now believe after a series of questions you answered, that we have a fairly good understanding of the important factors to consider. As a result, more crystals are being cut to this specification which will allow more effective tools for the Terrans. It would of course be more expedient if you were to give all of the specifics up front needed to optimally address an application of this technology, but I understand it doesn't work that way due to the established policy of the Prime Directive. Never the less, I respect that if that is so, and am grateful for your enduring all of my many questions.**

**JH (02-17-2023): I apologize for the stringency in the unfolding of this procedure.**

2) Does the 4096 Hz signal sent through the coil need to be a sine-wave or a narrow pulsed signal?

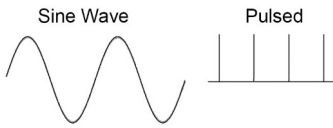

JH: To clear it: Sine-Wave

3) Would a signal amplitude of 15 to 20 volts be sufficient from our signal generators?

JH: The coil doesn't touch, so the risks are insignificant. But you must be careful not to use a power above 60 when you use a copper coil. Clearing a crystal requires no more than 20 volts. I had to check the voltage correspondence, as you know we do not use electrical voltage same as you do. It depends on the size of the crystal, the intensity of the clearing to be performed, and the personality of the crystal. Some are fragile, others very strong. You can feel that. Make sure you check for the presence of cracks in the crystals, or veins/ inclusions of other materials; these are weak points that could not end up well. In that case, reduce voltage.

Dan: Understood. Applications will be for clearing or erasing all previous imprints in the crystal before using it. Also for the generation of Phryll for healthful proposes as well as plants

**JH: Always use Phryll generation for beneficial purposes. Otherwise I am in trouble here. My brother monitors and records all our conversations. However, I am told that you can share all of what we have been talking about with the other Terrans, it is time they know.**

*(Remark from Elena: this change would mean that the DS is definitely losing power)*

**Dan: Grateful to be able to freely share this information to be used for beneficial purposes**

**JH (02-17-2023): Restrictions in sharing this information are lifted.**

4) Should the wire windings be in both clockwise and counter-clockwise directions?

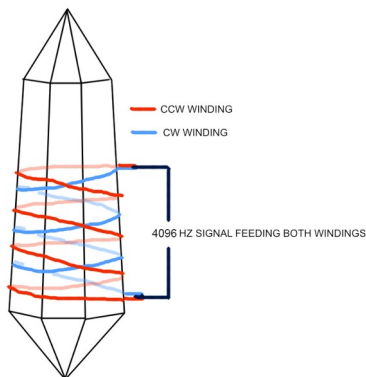

JH: here we are. Only one copper coil is enough to clear a crystal, wrapped clockwise. You know that your electromagnetic field is calibrated on the gravitational orbit of your planet around your star. That is why we do not say “clockwise” but “starwise”. I am sure Dan will like that. So I will use this term.

Using the two coils for sure will clear the crystal quicker, but it will also produce Phryll if the two coils are crossed at a 90 degree angle. It works also with a 45 degree angle but way less efficient to produce Phryll. Smoother.

If you have nothing to harvest it, the Phryll will radiate from the crystal. With small crystals it is not a big problem; the Phryll will regenerate and invigorate all living form in a radius proportional to its size. After which distance the Phryll will dissolve into the Ether. Plants love that, as I know your soulmate grows plants around you and she is very much fond of them. You can safely use a crossed double coil with small crystals. Just please, monitor the operation in case it sings. If the voltage is too high, it will.

Dan: Regarding Phryll harvesting. When the crystal is activated to radiate Phryll into the surrounding environment, is there any recommended methods to harvest that Phryll and deliver it to plants located in another area?

Such as having quartz crystals in the Phryll auric field to absorb the Phryll and then place the crystals in the soil next to the plant?

Or a container of water or even coiled tubing of water flowing around the crystal which can emanate Phryll into the water which is then used to feed the plants?

Can this Phryll be harvested using a geometrical form such as a pyramidal form and through geometrical quantum resonance transfer the Phryll to another location?

While on the topic of Phryll harvesting, I wanted to comment on the wonderful exercise to regenerate our DNA that you shared which can help in regenerating our Terran envelopes. You shared that this exercise helps to “reconnect the hydrogen links between the chromosomes' intra elements. DNA can be transmuted into a stable state of auto-regeneration once you unlock the blocks that keep the strands disconnected from the morphogenetic field of the universe.” I do feel very energized after doing it.

I wanted to check with you to make sure the variation of the way I am doing the exercise is effective and any suggestions you may have. Since I have an activated crystal with the 20 Hz pulses going to the silver electrodes to generate Phryll available, I do the following:

I sit in a chair and with my left over the top of the emitter end of the activated crystal without touching it in order to draw in Phryll through my left hand vortex, and with my right hand holding a small 6 sided Vogel/Eredyon cut crystal which I hold it with the emitter end pointing at my heart to assist in projecting the Phryll into my heart vortex with each pulsed breath with approximately every 5 Terran seconds between breath pulses. I do this while I visualize during each breath pulse that the Phryll is being fed into the heart vortex which is in turn feeding the upward toroidal energy flow from the base of my spine to the top of my head and back again recycling continuously and this flow is being fed with each breath pulse by the Phryll entering the heart vortex. I do this for a period of 3 to 5 Terran minutes duration per day. I wish to do this more regularly than I am, but first wanted to check with you on this procedure.

**JH:** You remember it well. This technology is used to remotely interface the Phryll generator with the energy supply devices. This is simple: the supply device is interfaced with the generator when the field activates. Once a surge of Phryll penetrates a living material, such as water, it will be stored for a while there, then it will be progressively assimilated and the surplus will be dissolved into the universal bio-field. Yes, as you heard it well, water is alive for it has a form of consciousness. I am not talking about soul, properly speaking, water has no soul, but it is self-aware due to its highly complex geometry properties. Water has a vortex structure due to the arrangement of its hydrogen particles. Not very far from your understanding of artificial intelligence. In other ways, naturally. But let me go back to your question.

Phryll charged water, water that has remained in the proximity of a Phryll generator crystal core device, changes its geometrical structure but it is temporarily. Water has a property that we call geometry elasticity. After a variable amount of time it reforms to its original structure. In the meantime, you can use this water to feed other living forms as long as it is kept within a glass container, that insulates it from the universal bio-field. In an open air recipient the Phryll will not stay forever.

**Dan:** Charging the water with Phryll is a convenient way of distributing the Phryll to multiple plants through the watering of the plants and even for human consumption as well, do you agree?

**JH (02-17-2023):** I agree, for sure ! Plants and other biological life-forms such as humans naturally feed of Phryll that is present in the surrounding ether, as you call it. Increasing the Phryll supply has not only an energizing effect; it also heals. When there is a wound or a disease, Phryll level is weak. Always let ether flow through your habitat. Confined habitat becomes poor in Phryll. Once a day, make a big draft or leave a window open in the sunlight.

**The question is how to effectively transfer the Phryll radiating from the crystal into the water to be stored in a glass container which can in turn be used to water the plants or be consumed?**

**JH (02-17-2023):** Place the charged crystal in the water container. It will change the geometry of the water.

**JH:** To remotely transfer Phryll from the core generator. Regarding your grade of technology available, apply a smaller crystal against the central core crystal, when the pulse signal is activated within the coil. The secondary crystal will bind with the central crystal by resonance. Leave it for a while, longer time for bigger secondary crystal size. Step 2: take away the secondary crystal and place it where you wish it to supply Phryll remotely.



**Dan:** The illustration above is showing my crystal with silver electrodes on the sides to pulse with 20 Hz to open the vortex and allow the Phryll to radiate out in the surrounding environment. This could also alternatively be a crystal with silver and copper coils creating a toroidal perpendicular conjugation that is being pulsed at 4096 Hz to generate Phryll.

**Question in regard to which configuration is more effective at generating Phryll?**

- 1) Crystal with silver electrodes on the sides being pulsed at 20 Hz
- 2) Crystal with silver and copper coils creating toroidal perpendicular conjugation that is being pulsed at 4096 Hz

**In this above illustration 6 small crystals are held with an elastic band against the central core crystal for Phryll transference. So long as the quartz crystals have a 52 (51.843) degree termination they will harvest Phryll by transponding to the central core crystal. Is this correct?**

**JH (02-17-2023):** it is correct.

**For the secondary small crystals to get fully charged with Phryll would this take less than a Terran hour do you roughly estimate?**

**JH (03-01-2023):** It would, yes, less than an hour roughly, depending on the size and character of the smaller crystals. The silver coins are rather useful to open the vortex singularity within the crystal, for it pulses compression waves either sides of the crystal's eye. You can operate onto the planetary morphogenetic field and the holographic planetary matrix, and affect reality. It produces Phryll, but the perpendicularly crossed wires around the crystal are best at producing Phryll. It doesn't work by compression pulses but in this case by creating torsion fields conjugated with the piezzo-electric charge of the crystal. This is best at producing Phryll.

**JH:** As an advice, it is better to use a perfect 4 sided quartz pyramid shape for a secondary crystal. Normal uncut quartz crystals work as well, Vogel cut crystals also, as the pyramidal angular ratio is identical so it can transfer Phryll anyways.



**Dan:** In the above illustration 6 small 4 sided 52 degree pyramidal crystals cut from quartz, these are not cut with respect to the lattice structure and will likely have quartz inclusions in them. Are these usable? They could be placed around the base to the central core crystal to harvest the Phryll and then placed near the plants. For the 4 sided pyramidal crystals, should they be touching the central core crystals as in the previous illustration or can they be in close proximity near the base to harvest the Phryll?

**JH (03-01-2023):** The 4 sided pyramidal crystals can benefit of the Phryll emission by only staying near the main crystal generators. The other crystals that you mention are usable, of course. All crystals take a charge of Phryll. They are quartz! They store Phryll, intention, anything.

**JH:** Never forget that you can also generate this process with your body and consciousness alone, holding a quartz – secondary crystal- in your right hand. In this case you are the central core generator, thanks to your DNA's natural ability to perform this. It refers to the practice I suggested to you at your request, recently. Then place the secondary crystal in a plants pot, onto a body, or in a chosen spot in your home. Or garden.

**Dan:** Excellent idea. After doing the Phryll breath exercise I can then use the crystal I am holding in my right hand that was directing the Phryll into my heart vortex that was conducted Phryll through my hand to transfer that charge stored in the crystal into water or plants.

**JH (03-01-2023):** Perfect, my friend. It follows the natural dynamic electromagnetic currents of the human body, the planet, the ether around. You are connected to everything. You can “paint” the matrix, be an artist of the ether by drawing Phryll patterns pointing the crystal at the invisible. There is a people named the Nhor, they do this at a level of pure creative perfection. You can see colors coming out of their dances with crystals in the ether, and sometimes, regarding the frequency of your species, you can hear music.

**Quartz captures Phryll and stores it. Unlike water in an open air recipient. Water in nature, rivers, oceans, rain...carries its own Phryll. We were talking about added surges of Phryll.**

**Quartz releases Phryll via electro-magnetic pulse. In a plant's pot by its own, not interfaced, a secondary crystal will only share the natural Phryll it generates naturally. Interfaced with a generator, it will transpond the Phryll from the central core generator to the plant or whatever else it is plugged to. Stop the generator's pulse, the small crystal will radiate out the surplus until it is back to its normal, natural quota of radiance.**



**Dan: In the above illustration is one proposed approach at collecting the Phryll into water containers that would surround the central core crystal. To be transparent to the conduction of Phryll into the water, the containers can be of 99.99% pure fused quartz, and then could be poured into glass containers with a glass lid to insulate the Phryll charged water from the universal bio-field in the environment before transferring into the soil of the plants or drinking it to charge up our Terran envelop. Will this type of pure fused quartz container allow the Phryll to pass into the water through the fused quartz material?**



**JH (03-01-2023): Yes it would, and do not forget to close the glass containers once with the Phryll-charged water. You can drink this water and bathe with it. Your spouse may try rinsing her hair with this water, she will notice a difference in the radiance of her hair. This water heals, it can re-pair disharmonics in the body and give you back joy and determination when you most need some. It extends youth.**

**Dan:** In the above illustration is another manner of harvesting the Phryll into water being circulated with 7 star-wise turns around the central core crystal.

**JH (03-01-2023):** This is an excellent way too.

Sharing a little Terran story with you... Dr Marcel Vogel did this form of information transference from the crystal into water for a winery (fermented grape juice) and converted thousands of gallons of wine that was circulated around the crystal into an award winning wine. In his case he use stainless steel tubing.

We actually use this arrangement for structuring of our water for our garden. It is by far not optimal, as it is a 12 sided crystal which we program with mind that has tubing made from a plastic material with 7 star-wise turns around the crystal.

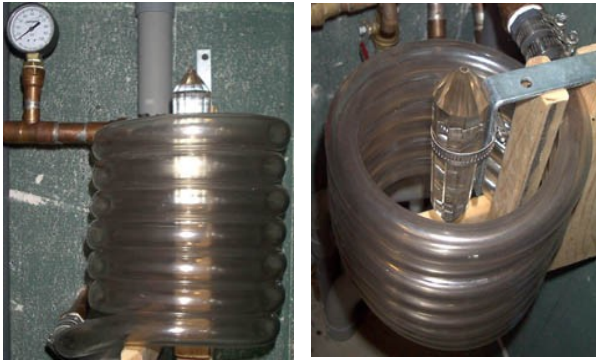

**Dan:** This arrangement with the water circulating around the crystal would be very conducive to energizing irrigation water being fed to agriculture.

Question would be if this form of Phryll transference into the water by circulating around the activated core crystal, what material of tubing would allow the greatest transference of Phryll into the water that is being circulated?

For example circular fused quartz tubing



**JH (03-01-2023):** quartz is the best option, but glass works very well because of the crystalline silica. There are types of hybrid glass-crystal material that work perfectly as well. I do not know what is the easiest way on Terra to get these materials.



**Dan:** The above crystal is the metal wire support structure for Elena's crystal. Since both of our structures are different, I wanted to ask on Elena's behalf, if there is any concerns with the metal wire structure if she wished to transfer Phryll to either water or quartz crystals?

**JH (03-01-2023):** the metal will create a meshing with the electro magnetic field it is better not have it, it could act like what I know to be called a Faraday cage, but the structure I see doesn't insolate the crystal. Due to its design, this metallic structure can rather increase the signal. What metal is it? This will determine my answer.

**Elena:** It is brass (*I show to him with my eyes, relayed via Thor Han, as the crystal is next to me*).

**JH :** It will not interfere in the opening of the eye. It will not constrain the production of Phryll, but the Phryll will adopt the pattern of the brass cage when emitted. Elena you rather have your crystal free from any cage, to correctly produce and harvest Phryll in a harmonious, linear radiance free from obstacles and interference.

**Elena:** Has this brass cage been a factor in the opening of the vortex that allowed me twice to hear distant voices or music?

**JH (03-01-2023):** Yes, it may have increased the signal in some ways. I like how you are experimenting. You find results by yourself, we are only guiding you. You make the discoveries. You are owing us nothing.

**Elena:** Well, I disagree there, we owe you a lot and we feel very grateful, Jen Han.

**Finally, regarding your personal procedure, I admire your intelligence in the matter, and you know exactly what you are doing. I approve, this variant in the practice is safe.**

**Dan:** Thank you for that. I am so glad to hear that. I feel much more confident now that the procedure I am doing is correct and will plan to do it on a more regular daily basis.



**Exercise illustration:** Drawing in Phryll from activated crystal with left hand and pulsing breath while visualizing Phryll being projected from crystal in right hand into the heart vortex which is feeding the upward toroidal flow circulating from the base of the spine up to the top of the head.

Note this is a variation of the original exercise given so the crystals used here are optional.

**JH (03-01-2023): This is good.**

Dan: Is this the proper winding configuration below of the two copper and silver coils at 90 degrees that can slide down over the crystal without touching the crystal?

**JH: no it must be strictly aligned in your second picture.**

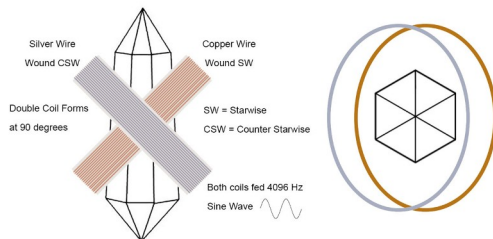

Dan: When you refer to the second picture, are you referring to the above image showing the side and top views of the crystal. If so could you elaborate on the alignment? If you are instead referring to Elena's illustration as the second picture showing interwoven silver and copper wires. Once again please elaborate, as Elena's illustration does not show 90 degree perpendicular windings.

**JH (03-01-2023): I am referring to the second picture above. I do not understand your question. The grey and the brown circles must be seen as one unique circle. Regarding Elena's illustration that you are mentioning, it is a wrong angle.**

**Dan:** If the above winding configuration is incorrect, I am trying to imagine how to wind the coils to create the 90 degree angle crossing for the toroidal perpendicular conjugation to work with the central core crystal for Phryll generation.

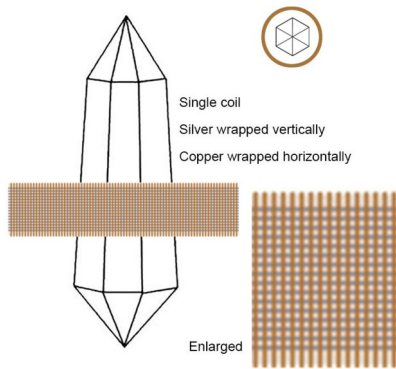

**JH (03-01-2023):** I understand it is uneasy to communicate distantly this way, for such precise information. I wish I could come and visit you. Soon I hope it will be possible. I see now your visual and I understand the confusion between us. Turn the whole wires configuration 45 degrees to oblique. Even if her angle is wrong, look at Elena's drawing. Do yo understand? The torsion fields will lock with the crystal. I will ask my brother to transfer visuals to Elena.

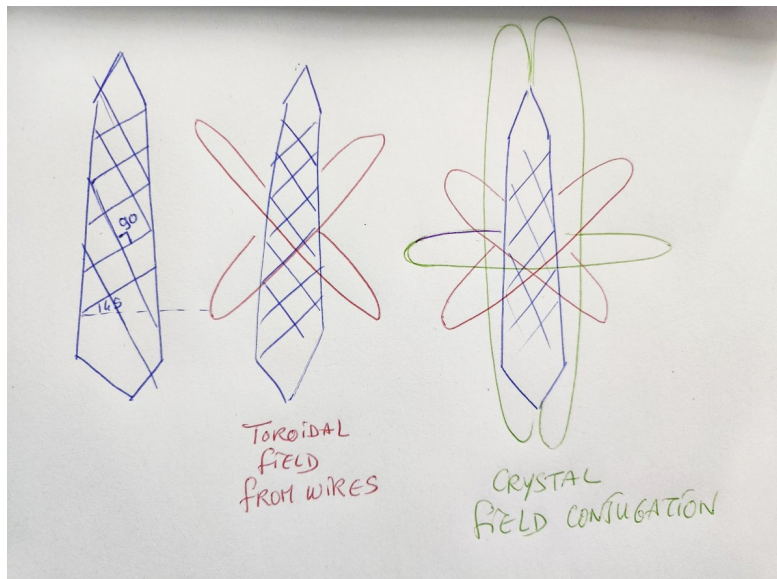

If the copper wire is wrapped horizontally around a circular form around the crystal and the silver wire is then wrapped perpendicularly at 90 degrees to the copper windings is one configuration. But I do not think this configuration would create correctly the two toroidal patterns to interact?

Is the Sine Wave also used in this configuration to generate Phryll? Or does that require a pulsed wave form for Phryll generation?

**JH: Pulsed wave is used for efficient Phryll production.**

4) You mentioned using silver or copper wire. Are they both equally effective using one or the other? Can they be combined together where one is wound clockwise and the other counter-clockwise? If so which would be clockwise and counter-clockwise?

JH: Silver wrapped counter-clockwise and copper wrapped clockwise. Copper works with the electromagnetic field, silver works with the etheric field and compression waves. The crossing of the both creates energy because it generates a torsion field. If the power reaches a certain level, especially if coils are crossed at 90 degree angle, two perpendicular toroids will form and the antigravitic process will activate. The crystal will lift above its support. If when this happens, the crystal is constrained and tied up to the support, it will explode. Never mess with torsion fields, we fly starships with this technology.

Dan: I will keep the power level below 20 volts to be safe.

Dan: In Elena's book "The Seeders" she did an illustration of a crystal generator with golden and silver coil windings around the crystal. Note that I enlarged a section and inserted it for closer viewing of the double coils.

Elena described the following:

*"The Crystal Generator I was shown on a distant world. This culture uses the vibrations of sound, chanting and hitting the metallic mesh on the ground, to send impulses to the crystal coiled with golden and silver metallic threads. The Pyramid Crystal Generator I saw in the Uhurai Valley on planet Erra, in the Pleiades. The crystal is also wrapped with double coils."*

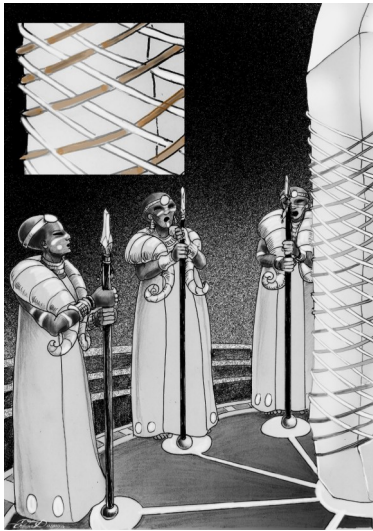

Image property of Elena Danaan from her book "The Seeders"

Dan: The coiled silver and golden (gold or copper?) windings around the crystal in Elena's illustration appear to be interwoven and at about a 45 degree angle to each other. I can see how the two windings can be wound like this to be at 45 degrees but not at 90 degrees in this particular configuration. Does this illustration relate to the correct way of winding the two coils to form the two perpendicular toroids?

**JH: I do not know on which world this was observed, but it would seem to me that this is incorrect, it should be a 90 degree angle crossing for the toroidal perpendicular conjugation to work. A crossing at a 45 degree angle works although in lesser effect. It would seem to me that a culture which knows and uses this technology is also aware of the 90 degree crossing angle for the coils.**

*(commentary from Elena: I saw this very quickly and in a motion, so I accept that I may have made visual mistakes in the way I depicted this scene).*

**Dan: If you could provide to Elena some form of imagery of how these two coils are wound in reference to the core crystal, that would help us in understanding how to form these two coils around the crystal.**

**JH (03-01-2023): I will give her another one:**

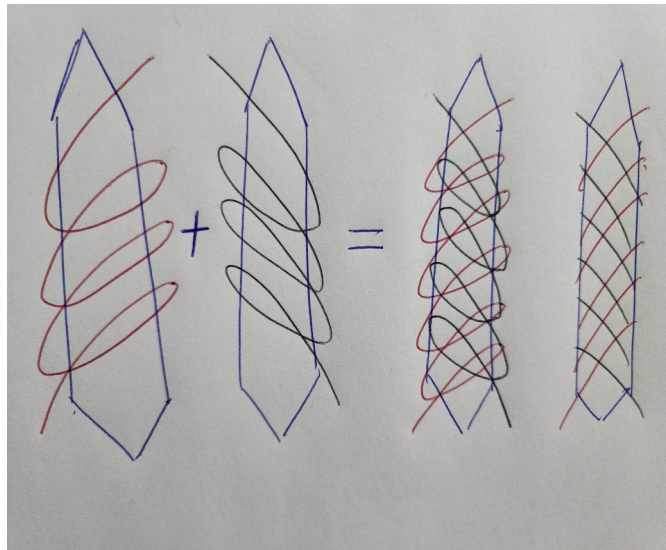
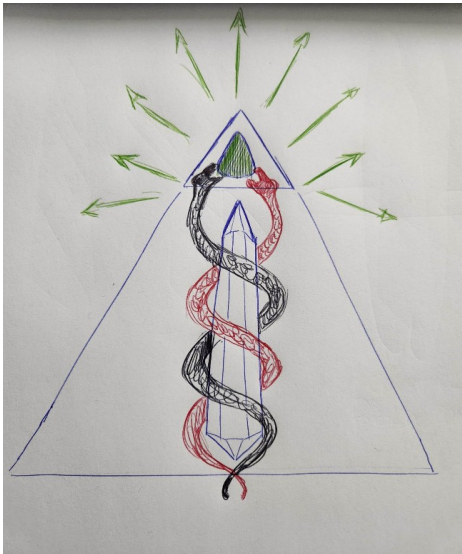

5) Should the windings cover the entire length of the shaft or just in the vortex area of the crystal?

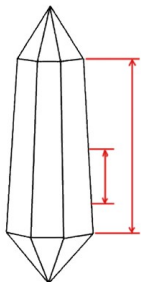

JH: There is no rule for this but always stop, above and below, a bit before the angle that delimitates the start of the 2 points of the crystal.

**JH (03-01-2023): No exact rule, it is a matter of choice. The vortex area is enough to produce Phryll, winding the whole shaft increases power.**

6) Do you recommend winding around either the crystal directly or a coil form with a high density number of turns or less density?

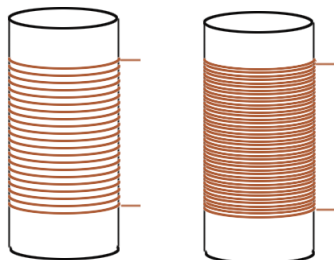

JH: It is always better when the coil do not touch itself in the winding. The denser the coil, the denser is the electromagnetic field. It can touch but it is more powerful when it doesn't.

Dan: When you refer to not having the coil touch itself in the winding, is the concern here that the electrically conductive wires would, as they say on Terra, “short out” by the electrical signal jumping over and connecting to the next wire? Or is spacing preferred between the wires for another reason why they should not touch, to be as you said “more powerful”. I ask, because the wires of both silver and copper are available to come with an insulation coating to prevent the wires from conducting to each other, so they could be wound tightly together for a denser electromagnetic field.

**JH: Insulated wires is good, although what material is it made of? It must not interfere with the electro-magnetic field generation. Copper and silver touch when crossing each other, no matter which is on top of the other as they produce a different signal, but it is better that a coil of a same metal do not touch. Each wire must have its electromagnetic radiance free flowing around it. This is important if you want to generate Phryll in a powerful and productive way. If the coiled wire touch, it will not cancel the effect but it will weaken the results considerably.**

**Dan: The insulation material does not interfere with the electro-magnetic field generation as this insulation is commonly used in transformers which induce fields to secondary wire windings. When you say the coil of the same metal should not touch. If the wires are insulated and the wires are up against each other wound tightly together, only the insulation of the wires will be touching each other and not the metal. Or does there need to be a small space between the insulated wires so that each wire has an unobstructed free flowing field around each wire as in the example image below on with the coil on the left with greater spacing?**

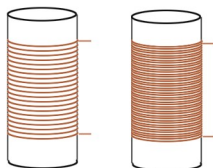

**JH (03-01-2023): It is better wires not touching and without insulation, but the type of insulation you are mentioning is suitable. I insist on letting the coils breathe. You are not producing electricity but Phryll. Space between the coils matter. Even with insulating material. Our way is without insulating material, with breathing coils. The crystal also must breathe, that is important. Light must flow.**

**I will now tell you this, remember well my friend:**

**Void is equally as important as matter.  
Phryll bridges void and matter.**

**The unshapable concepts that your mind senses through the frequency of an emotion that connects you to the essence of knowledge, are as equally important as the physical words you read on a solid support.  
Consciousness bridges concepts and words. Unshapable emotions and written symbols.**

**One is vital to another just like a copper and a silver wire to the core of the universe.  
Red and white  
Female blood and male sperm  
Degeneration and generation  
Death and life  
Void and matter  
Copper and silver  
The two serpents**

**Human DNA is such a thing; the invisible strands are here although you cannot see them or measure them, as necessary as the palpable ones. The two serpents aren't two different types of atomic arrangement of matter. No, they are the Alpha and the Omega. They are void and matter. They are created and uncreated. Yet, existence and non-existence. Construction and deconstruction. The electrodes of the Universe that sparks Source. Source is dual in such ways.**

**When you set the two serpents free to dance around the crystal, they create the very essence of Source: Phryll.**

**This is a reproduction of the great creation. This is powerful, my friend, and it is unlimited and it is free. It is not only about crystals, it is about so much more, it is about everything. Once you understand this, you are free.**

**Once we understand the form of the two coils to take around the crystal, the next question is the density or number of turns per coil and if the thickness of the wire is relevant? Since we will be using a low power level, thinner wires may be acceptable. I realize there are a number of complex variables in all this and don't expect exact numbers or formulas, only a general guideline to obtain an effect. Apparently Elena and I followed correctly your instructions for our crystals with the silver electrodes and Thor Han did confirm they were able to open the vortex, so I'm sure we can do it again with your help.**

**JH (03-01-2023): There is no precise measurement between the coils. When the possibilities reach infinity, your heart knows the way. If my guidelines remain unclear, please ask me again.**

The time required you said will not take very long and that we will be able to sense that it is cleared. You also said that it is safe, but to be aware of not letting the crystal sing. So this application of 4096 Hz to the crystal may take less than one Terran minute to clear?

JH: Yes, less than a Terran minute.

8) When using the 4096 Hz tuning fork to “brush” these oscillation over the crystal, do you recommend applying the sound perpendicularly to all 3 axes of the hexagonal crystal?

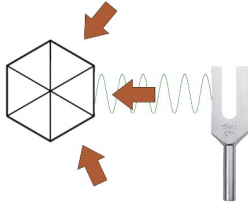

JH: yes.

As always, thank you Jen Han for clarifying these methods of clearing the crystal, as it is logically the first process to address before performing applications with the crystal. I hope some day we can meet in person my friend.

JH: Dan, my friend. I know we will, when all of this will be over. I am here and not going anywhere, so I am always ready to jump in a scoutship and come and visit you, but this is not the moment yet. One day soon, it will be. We keep in contact and I am always happy to answer your questions. It is getting more exciting each time. I have all clearance to disclose these technologies to you, now that my brother can give these clearances from the high command circle. You only have to ask questions, that is how these things work. As you know.

Much enjoyment to come.  
Your friend Jen Han Eredyon.

Dan: I have great gratitude for you and your older brother Thor Han, who I wish to congratulate for being promoted into the high command circle and whose authorization is allowing us to have these communication exchanges possible, and to your wonderful emissary and my dear friend Elena who provides the quantum communication link in order to bring this knowledge to the people of Terra. Elena and I are excited to receive this knowledge as we are planning to teach a series on crystal technology to empower the Terrans with knowledge of crystals working together with love and our creative power of consciousness to help transform our world.

Jen Han my dear friend, I greatly look forward to the day when our planet is liberated from the dark elements and that you can come and safely visit me here on Terra. Since I was a child on this planet I've always wanted to meet a being from the stars such as yourself. I know the day that happens, it will be very transformative to my current perception of reality and I greatly welcome it, as it is time the full truth to the world is known and the deceptions exposed. I have faith that our planet is indeed on a positive timeline trajectory and that we are about to witness an amazing transformation that will as you

say bring much enjoyment to come! I look forward to when we can all celebrate together!  
Thank you for your friendship Jen Han  
Your friend Dan on planet Terra

**JH: My good friend Dan on planet Terra, I apologize for not being able to converse directly and physically with you, and for the difference of time flow. I know for sure that your planet is on the right path. I am following the events closely. My brother thanks you for your kind words and he wishes you good health and successful implementation of this technology. He says that he always keeps an eye on you. Understand this in the good sense of course. Terra is a whole world of exciting natural discoveries for someone like me. The bio-diversity is wonderful and so rich. I can not wait to have clearance to come down on its surface and see it for myself. In that case I will visit you and check your crystal installations and devices together with you.**

**I will bring a flask of ionized drink.**

**Your friend Jen Han from Erra.**

**Dan: Jen Han my dear friend, I would love to have you visit and have a joyful celebration with you enjoying some of your ionized drink and making a toast to a beautiful future ahead for the liberated planet of Terra. (I hear they serve this drink onboard the Excelsior and that it is intoxicating yet healthful)**

**Yes, it's quite a zoo down here, you'll absolutely love exploring it's vast diversity of life once the dark control elements have been removed so you can have clearance. It's fascinating to me that you saw with your technology and shared a few details of my past life in Atlantis and that I was a scientist working with crystal technology and that my field of expertise included medical holographic science. This is something I happen to have a great interest in. My Terran age at 73 years is getting closer statistical average of envelop expiration of 75 years, but I know I will exceed that average. I have so much yet to learn, love and explore such as yourself, so I like many others on this planet in which Enlil tampered with our DNA template to shorten our lifespans, that the release of the holographic medical pods appear to offer great hope for extending our lifespans considerably, so that we can enjoy a great deal more years and alleviate the pain of suffering of deteriorating envelops. What an incredible blessing that would be to billions of Terrans. This gives great hope for us so that we would be able to 'live long and prosper' as a Terran science fiction entertainment actor pretending to live in the future once said.**

**I greatly look forward to our further communication exchanges and sharing this knowledge with the people of Terra for the good of all beings**

**Your Terran friend Dan**

**JH (03-01-2023): My friend, Dan. This time will come and you will live longer than the average envelop expiration on your planet. And so will your beloved spouse. Together you still have a long and prosperous life to experience.**

**Your friend from Erra.**

## Jen Han Eredyon Session – 03-15-2023

Greetings Jen Han my friend, Grateful you have been authorized to share this information and I am excited about developing the Phryll generation and applications for the people of Terra that will be used for beneficial purposes only.

JH: Greetings my good friend from Terra. We are collaborating you and I for the good of these people who have been enslaved in chains of ignorance. For so long! Of course for my perspective of time, it doesn't seem as a long time has passed, but to your people it does, tremendously. I hope we can collaborate further as time passes, far into the future. Keep on doing your daily exercises harvesting and harnessing Phryll. I will now answer your questions.

Thank you for bearing with my long series of questions in order to get clarification. I respect and appreciate that this is the way our question and answer exchanges are required by the Prime Directive.

Before going into Phryll applications, I would like to summate for your final feedback the various methods we've gone over that are used to clear the crystal of previous imprints. This will be one of the first topics that Elena and I will be teaching the Terrans. Previously we dispelled some of the Terran folklore beliefs that are ineffective at clearing a crystal, such as using salt, burying in the ground, chanting, smudging with sage smoke or exposing to sunlight or moonlight to name a few.

So far we know of 5 methods to effectively clear the crystal. They are...

### 1) Pulsed breath with conscious intention to clearing

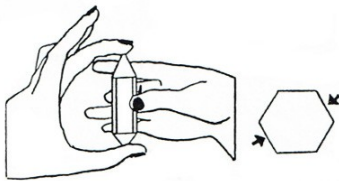

Dr Marcel Vogel used this method where you place your middle finger and thumb on each of the opposing faces of the crystal and pulse your breath coupled with conscious intention and visualization to clear the crystal. Rotate to the next set and repeat. For a 6 sided this will be 3 times for the 3 axes.

Jen Han added that the mind of the user must have reached a clear state of mind so as to not project parasitic thoughts into the crystal if the users mind is troubled.

JH: yes, this is important. No clear mind, no clearing.

## 2) Magnetic bulk eraser



Dr Marcel Vogel recommended this device which creates a powerful fluctuating magnetic field at 60 Hz that can clear a crystal by deprogramming it. Possibly in some ways similar to how this device is originally intended to erase magnetic tapes. Typically, no more than 10 to 20 seconds of exposing the magnetic eraser against all the sides of the crystal is adequate to completely erase previous imprints. It is safe to make physical contact with the surface of the crystal with the magnetic eraser for the greatest induction intensity of the magnetic field into the crystal lattice structure.

## 3) 4096 Hz sound from tuning fork

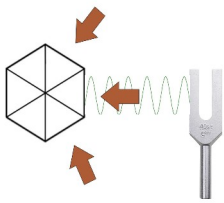

Jen Han has said to use the sound of the tuning fork to brush closely over the 3 axes of the crystal without touching the crystal and while you are doing this to couple this with consciously visualizing the crystal being cleared. This should take far less than a minute to complete.

## 4) 4096 Hz sine wave through single copper coil

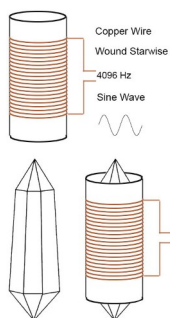

A more advanced method is having a coil form that is electromagnetically transparent with copper wire wound in a starwise (*what Terrans call clockwise*) that can slide down over the crystal that is connected to a signal generator to output a 4096 Hz sinewave with an amplitude of around 20 volts. This takes less than one minute to clear the crystal.

### 5) 4096 Hz pulse through double copper/silver coil



An even further advanced method is two coils of wire, one copper wound starwise and one silver wound counter-starwise that are perpendicular at 90 degrees to each other and pulsed at 4096 Hz from a signal generator. This will effectively clear the crystal in a shorter period of time than the single coil.

This concludes the known crystal clearing methods. The majority of people will no doubt be using the first 3 methods. Your thoughts on all these methods Jen Han?

JH: You summarized perfectly what we have been exchanging about in the last couple of months. The double coil system is not worth the trouble to set it up, when you only want to clear the crystal. A single coil suffices. But of course, the result with double coil will be faster, very fast. Nearly instant in some cases. Show them first how to obtain a tool – quartz- that is clear of any imprint, and ready to be used. A virgin ground has the most powerful, radiant geometry.

They need to become conscious of how effective is the power of manifestation. It affects matter, the lattice of reality, and propagates effects into adjacent densities. All is resonance, across time, matter, energy, and densities of consciousness. You see, consciousness' expansion is related to the frequency rate of reality. When particles vibrate faster, the mind computes faster, consciousness expands farther and intelligence expands with it. We see better, clearer, farther. We think faster. The force that binds protons and electrons together is a vibration, that has a specific, very precise frequency rate. If you alter the frequency rate between particles, you change the solid reality. Thus you can heal by repairing tissues, because you will re-pair the broken links due to a dissonance of frequency. The universe tends towards...

There you have it.

# Jen Han Eredyon Session – 2023

## Phryll Generation, Harvesting and Application

Seeking here the instructions for the correct method of forming the double copper/silver perpendicular windings around the central core crystal that creates the torsion fields that conjugate with the piezoelectric charge of the crystal in order to generate Phryll to harvest and apply it for beneficial purposes.

Your visuals you transmitted...

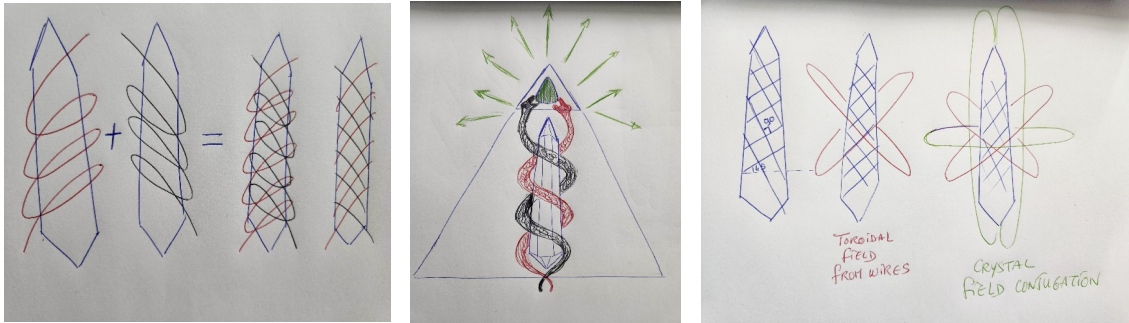

### Questions:

1) Are the double crossed copper/silver wires required to be wrapped around and touching the crystal, or can they be wound on an electromagnetically transparent coil form around the crystal?

JH: my recommendation: wires do not touch physically the body of the crystal, but they stand very close. The vibration of the wires is free when not touching with the crystal, but the wires must be close enough, nearly touching the crystal, to send pulse into it.

2) If the two windings are to be wound onto the crystal surface as in the below illustration showing 7 turns of copper starwise and 7 turns of silver counter-starwise at 90 degrees to each other. Is this enough turns or should more turns be applied?

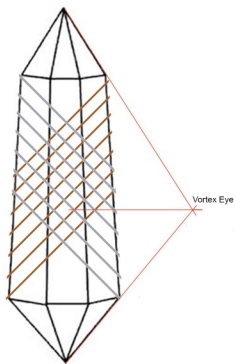

7 turns



5 turns

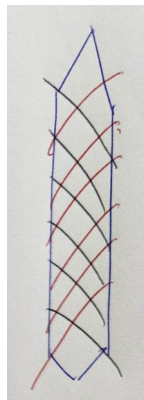

Reference image

JH: figure with 7 turns is better. More coils= more power.

3) Is the spacing good in ether of the above illustrations?

JH: figure 7 is good, you can double it.

4) Is it more effective to have thicker wires than thinner?

JH: the effect is the same, the torsion field activates. Power is not about thickness of wires but a faster rate of pulse.

5) Is it required that the wires are interwoven as in Elena's previous illustration below?

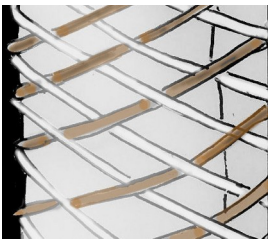

JH: No it isn't. She wasn't explained the complete science when she drew this. However, it may occur that some cultures do as such. It is effective as well, but not necessary.

6) If the wires are not interwoven, is the correct sequence of wrapping the wires as in your diagram to first wrap the copper wires starwise and then wrap on top of the copper windings the silver windings counter-starwise?

JH: There is no order which wire is inside and which wire is outside. The torsion field activates in the same way and measure of power.

7) If an electromagnetically transparent cylinder form had the wires wound on it, how close to the crystal does the form need to be in order to be effective?

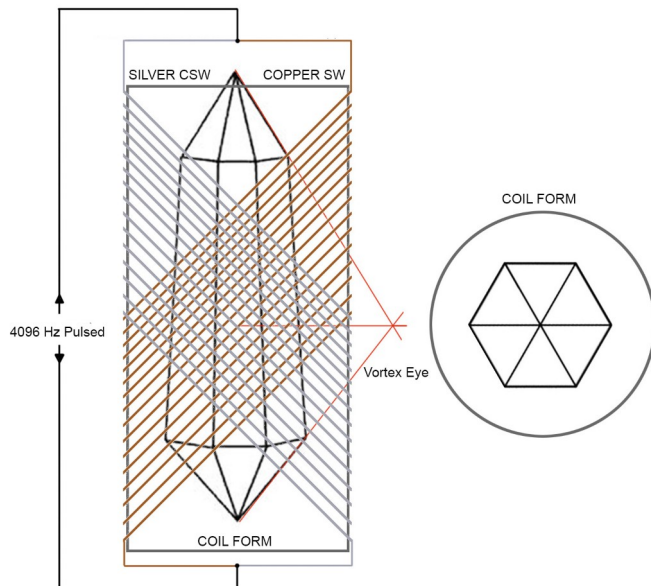

16 turns around a coil form

JH: Based on this visual: one half to one fourth closer. Best ratio is one fourth.

8) In the above illustration with the copper and silver wires wrapped around the form, is the electrical connection of the copper and silver coils as show the correct way to connect to the 4096 Hz pulse coming from the signal generator?

JH: it is correct.

9) In the above illustration it shows as an example, 16 turns of wire for copper and silver, is this more effective than the previous diagram with only 7 turns of wire each? Or as you said, it is important to have the space between the wires to allow each wire to have it's field free flowing?

JH: Space between wires can be equal to twice the diameter of the wire.

10) In the above illustration the two coils cross perpendicularly at two opposite areas surrounding the crystal, should these areas be aligned with one of the three axes of the hexagonal crystal as in the below illustration indicated in red or is that not critical?



JH: this is not important. Remember: it is here about generating a torsion field.

11) Is the amplitude of the 20 volt pulse signal sufficient for adequate Phryll generation or would more Phryll be able to be generated increasing the voltage to not more than 60 volts?

JH: It depends on the size of the crystal. There is a mathematical equation for the ratio to be found. It involves the height, inclination of the sides, diameter, number of sides, clarity of quartz, and so forth. Consider that if you are using the same crystal as Elena, you can increase the voltage, do it progressively. You will experience a tightness coming from the crystal that will tell you where to stop. Twenty volts is working and it is the most secure rate. You can if you want push it to 40 volts progressively, wait on that threshold, then increase slowly and gently up to 60 volts, BUT never instantly, for the shock can shatter the crystal. Always starts from 20. Regarding the size of your crystal, do not go over 60 volts. If you want to power big devices, you need a bigger crystal.

12) Any suggestions on how on your planet Erra you form these wires around the crystal and how you hold the perpendicular wires in place? Do you use small crystals like we have with the double crossed coils to generate Phryll or do you get Phryll instead distributed to you by large central crystals?

JH: very interesting and unexpected question, my friend. I will reply. On my homeworld, we have power generators such as those you know from Atlaa. I wish I could converse with you directly from face to face, how exhilarating it would be. Anyways, on Erra, we do have central power plants. Pyramidal power plants with a tall natural crystal in the center core. The Phryll harvested is collected in the top of the pyramid and resonated, or you may understand better the term "teleported", to smaller devices, that we name secondary generators. These transpond the Phryll for and towards the power web of our cities. In countryside settings, each house can choose to own a small replica of the big pyramid generators, or we can either have a generator that supplies a whole community. That is how we have organized where I am coming from, Edora-Ur in the Nardaryen valley. We are relying upon a community generator on the hill above the valley. It supplies power to all the habitats. This is stable and greatly efficient because of the lake. The water. Phryll generators are always near water. Our sister works as an attendant, she is part of the maintenance team. It is more of an occupation for her.

Wires are coiled near to the crystal, without any material in-between. The touch the ground and at the top they are terminated by small metallic spheres to each of the wires' ends. The spheres' pulse is also gathered by the top device, as no energy is lost. You do not need these spheres terminations to the wires when you work with a small crystal as you do, but for the big power generators, the spheres generate plasma and this, as well, is gathered. The torsion field can be harmful when activated so no one is in the generator room when it is on. With the small crystals, of course, there is no danger of molecular deconstruction. As I said in an earlier conversation, do not play with torsion fields, you need to exactly know what you are doing.

13) What is special about the 4096 Hz frequency in relationship to the quartz crystal lattice structure? and why does this frequency act to clear the crystal of previous imprints?

JH: This is a frequency rate that disassembles the bounds between the particles of lower frequency that are not in resonance ratio with a quartz lattice structure. It breaks them down, so the intrusive particles are vibrated out of the body of the quartz. The Quartz regains a perfectly balanced, geometrical absolute, state of resonance.

14) Why does the pulsed 4096 Hz frequency with the dual copper/silver coil which creates the toroidal perpendicular conjugation with the piezoelectric lattice of the crystal generate Phryll?

JH: 4096 Hz rate activates the geometrical resonance of a quartz lattice. Combined with a torsion field it creates Phryll. As you know, there is more than one way to extract Phryll from the ether. All you need is a scalar wave passing through the installation. Such as for example: sound frequency compresses the etheric field, brain waves do this as well when powered by consciousness. Gravity, breath, and other elements.

15) Does the cross dual copper/silver coil work primarily for the torsion fields created to generate Phryll and does not open the eye of the crystal, unlike the silver electrodes that send compression waves to open up the eye vortex. How are these two different? Is one for consciously connecting into the vortex to affect reality in the matrix, and the other primarily for generating Phryll?

JH: I explained this already. The eye of the vortex can only be stimulated by compression waves at a specific point in the shaft of the crystal. Such as breath, consciousness, electrical pulse. It generates Phryll, but it is not the most powerful and efficient way to do it. The most efficient way to generate Phryll is by activating a torsion field through the quartz, which converts the crystal into a generator.

16) For harvesting Phryll from an activated crystal in order to irrigate plants with the Phryll charged water, is the exposure time for water flowing around the crystal in 7 starwise turns in fused quartz tubing sufficient to adequately transfer the Phryll into the water to deliver to the plants?

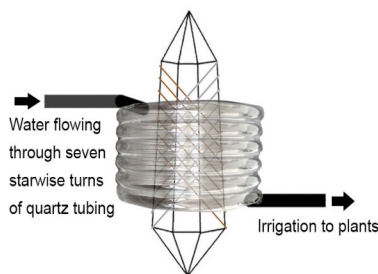

JH: It is more than efficient. 7 time 3 is the number of creation. The third of 21 acts efficiently on the geometrical lattice of water, mutating its core pattern into that of quartz. When the quartz is equipped with a Phryll harvester, I intend to say the coils, the Phryll transfers to water. The water becomes a conveyor and a medium to contain the Phryll for a while, unless you lock it.

17) In the above illustration, should this unit be housed in such a way to allow the Phryll to accumulate and possibly reflect around the quartz tubing coil with water flowing through it and not allow it to dissipate into the surrounding environment to be more effective? What material would you recommend to contain the Phryll? Such as glass or?

JH: Glass is the perfect container, if not crystal itself.

18) Besides dowsing rods, is there a way you would recommend to be able to measure the output of Phryll from the crystal? Is there any artifacts of the Phryll that Terrans can measure to indicate the presence and quantity of Phryll?

JH: biofield measurement devices capture it, also anything that can measure an electromagnetic field, but I do not know about the whole range of technology available on your planet.

19) Update on Elena's crystal support framework. The material which looked like brass is actually steel with a brass like coloring coating. We discovered that by placing a magnet which stuck to it, which brass is non-magnetic. In light of this, any new considerations regarding this?



JH: Yes, this is concerning if she wants to set a double coil Phryll harvester on this specific quartz. Better bare from any magnetic metal around the shaft of the crystal. Only copper and silver must be the active metals.

Because I know now that this is a magnetic frame: this setting here, that she has, amplifies the activation of the vortex by magnetic resonance, but it creates a disturbance in the Phryll field around the crystal. It shapes the Phryll in the pattern of the metallic frame. Entertaining but not efficient for harvesting.

20) What is the optimal method for using Phryll for human regeneration and healing? Drinking the water or absorbing from the Phryll auric field in the environment? Or doing the breath exercise you showed us in feeding the upward flow through the body being feed through the heart vortex using pulsed breath?

JH: These three methods are effective; the breath exercise is best efficient. Drinking the water is second, Phryll absorbing by breathing the air and bathing in sunlight is three. Photon waves from your star are also compression waves creating Phryll. Hydrodynamics of your oceans produce Phryll, same as wind. It feeds the oceans and the air with life-force energy.

21) Healing the body application. For example, a shoulder joint that has lost it's cartilage (*such as mine to experiment on myself*), in order to help regenerate that cartilage using Phryll, how would you recommend?

JH: Phryll, by breathing Phryll with your consciousness, into the wound, it will revitalize the defective energy field in that precise area in your body. Where there is a body defect, the biofield is weak. The electro magnetic resonance is weak. The flesh cannot repair quickly. So breathe Phryll into it when you perform the exercise I showed you. By the drive of your consciousness. Your mind is in control of where the Phryll goes inside of your body. You can gather Phryll in your hand and apply your hand above your flesh. The distance between the hand and the wound, you will feel it.

Bathing in Phryll infused water will be less effective than a dynamic of Phryll transfer led from inside the body.

When outside, expose your shoulder to the wind, a warm enjoyable wind, and with the power of your mind, bring the Phryll that is carried by the wind, inside.

Wind, my friend, carries Phryll in the same way that your breath does it into a crystal. So catch it and bring it where it is needed most.

22) Is there a possible application for telepathic communication with an open vortex created with the silver electrodes on the crystal such as what Elena experienced of hearing Japanese music playing through the vortex from Jean Charles' mind when her crystal was activated and the vortex was open?

JH: I will answer this next time. I need clearance.

23) The 2 circular perpendicular coils of copper and silver in the below configuration on the left is not as effective for the toroidal perpendicular conjugation to work as the configuration on the right, is this correct? I ask because the one on the left is very easy to construct around the crystal.



JH 29-03-2023: the one on the left works but less efficiently than the one on the right.

An electromagnetically transparent coil form can be used to wrap the copper and silver coils onto that surrounds the crystal as in the below illustration.

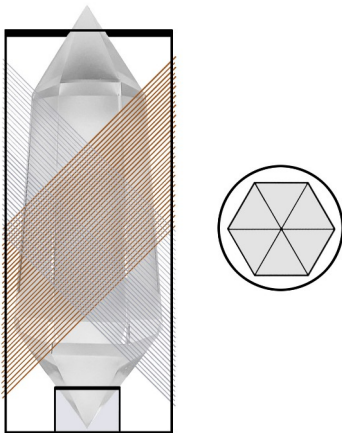

This coil form needs to be as close as possible to the crystal without touching it.

JH: yes

The more turns of wire the more powerful, so have as many turns as possible.

JH: yes

The crisscrossing of the wires should not extend into the crystal termination area.

JH: Exact. It is a question of dynamic geometry.

The wires can be thin wires

JH: Yes

The spacing between the wires is twice the diameter of the wire

JH: Yes but once the diameter as a spacing works as well. It intensifies the field. Twice the space is safety, once the space generates a more aggressive and powerful field. The crystal tells you what it prefers. Never forget to always work using consciousness interface, with quartz. If you do not take this element into account, it is like wanting to fly a ship without a pilot or a navigation system.

My good friend Dan, I am happy to continue communicating with you, I will be waiting for your missing visuals at the bottom of this list. Until then, be gentle with your body, rely on mechanical technology rather than muscular efforts, gentleness is the word. Honor your body, it carries you well. I will look forward to read further more from you.

Your friend Jen

## Jen Han Eredyon Session – 03-29-2023

Reference: 22) Is there a possible application for telepathic communication with an open vortex created with the silver electrodes on the crystal such as what Elena experienced of hearing Japanese music playing through the vortex from Jean Charles' mind when her crystal was activated and the vortex was open?

JH:26-03-2023: I will answer this next time. I need clearance.

JH 29-03-2023: Communications is not my sector of research and work, and these technologies are included in the program of disclosure with the Terran Alliance. My brother knows better about these matters. However, I can share this with you.

The vortex opened in the crystal, when the eye is activated, can collapse by entanglement two points in space and time. If you have the coordinates of the receiver, you can exchange information not by sending it but by sharing it, collapsing space-time. You are using hyperspace. You know this by the name "quantum". But it is more than "quantum"; you access the Void. You can connect with any point in space but also in time. Future, past, the Megopei galaxy, even the far Aldeeran galaxy. In one click, when you switch on the pulse. You need a signal amplifier if you want to physically hear a voice, otherwise it will be received in your mind directly. A metallic grid is very basic but it can work. We have much more advanced technology. This procedure is similar to the communication I am having with Elena when I am onboard my brother's ship. Not like now, when he is relaying the conversation via his implanted communicator. When I am next to my brother in his quarters, I can hear Elena talking physically, with my own ears, because her voice signal is transponded and amplified by a device we have. These devices are powered by very small crystals. Quartz for the communication and mercury iodide for the Phryll powering.

The below Illustration is using an electromagnetically transparent coil form being used to wrap the copper and silver coils onto the form that surrounds the crystal.

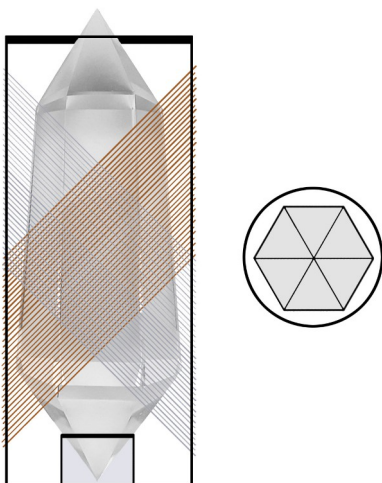

24) In the above illustration using a coil form, I understand it is best to have nothing between the wires and the crystal. Would using an electromagnetically transparent coil form that the wires can be wound onto and held in correct position and spacing be usable in this manner?

JH 29-03-2023: Yes it is usable.

JH 29-03-2023: round is better but the hexagon works too.

25) Note in the above image that due to the tapering of the crystal the wires are further from the crystal at the top than at the bottom. Is this much of a concern? In other words, would a straight sided crystal rather than a tapered crystal be more appropriate for Phryll generation in this application?

JH 29-03-2023: straight sided is best if you want to fly a ship with mass cancellation. For Phryll production, tapered is right, knowing that straight is also good. The tapered effect is sending the Phryll produced towards the conjecture point of the angle of the faces of the crystal's shaft, to a location well above the crystal. This is the gathering node for the great generators, where we interface the other devices. The top of the pyramid will be at this exact node. You do not want to power a planet. Or do you? Let me guess.

You do not have the gathering devices yet, but you can use a glass sphere with void. The problem is you need the quantum technology to transfer the energy from the sphere to a remote device. In our ships we also you a conical harvester. This is another door my friend.

26) In the above illustration is the positioning of the crystal relative to where the wires crisscross correct?

JH 29-03-2023: Yes, correct.

27) Does the metal of the copper and silver wires need to be 100% pure. i.e. 97% pure acceptable?

JH 29-03-2023: 95% pure is the limit so the 97% is acceptable. I had time to make research on the properties of these two metals as they are found on Earth, because my brother scanned the questions for me yesterday. Silver and copper have the same atomic arrangement wherever you find them in the universe, but they have different electromagnetic capacities regarding the electromagnetic field of the planet where they have formed. This doesn't fluctuate, it is constant.

28) Is it permissible if the copper and silver wires make electrical contact to each other or should they be insulated from each other?

JH 29-03-2023: Best if they don't connect.

29) Would a very thin insulation coating on the wires which is electromagnetically transparent be permissible? On Terra the copper wire uses a very thin enamel coating to keep wires from shorting if they touch each other.

JH 29-03-2023: Yes, if you trust this material, it is very possible. You can go ahead with this solution.

30) Another possibly better way to place the two coils around the crystal could be with 6 vertical pillars with the perpendicular grooves for the copper and silver wires to go around the crystal in a hexagonal manner as in this below illustration. This allows the wires to be in more of an open framework and closer to the crystal. The wire coil is formed hexagonally rather than circular in this configuration, is this usable?

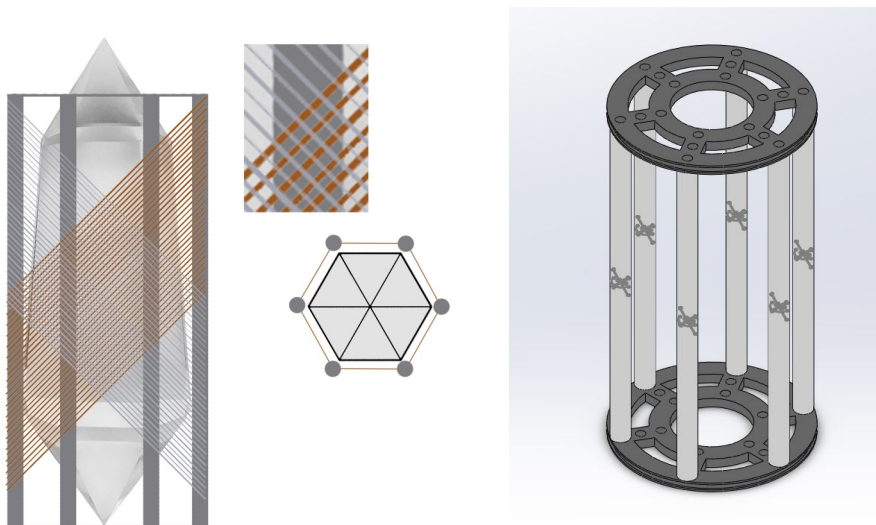

JH 29-03-2023: I have had a look at this visual. As I said, round is better but hexagonal works also. The torsion field is generated. Remember that geometry is a key to the lattice of the universe.

*Thank you my dear friend Jen Han in answering all these questions which are moving us closer to correctly constructing a Phryll generator on Terra. This information is a wonderful gift from your people to the people of Terra, and I am grateful and honored to be able to bring this technology out and share this.*

*Your friend Dan*

My friend, Elena told my brother that you have now associated with qualified humans to work on these projects. Thor Han informed me that a list of their skills is available so I will read it when transcribed. I hope sincerely that my answers to your questions are satisfactory. I wish one day to meet you all, and I know that this day will come. Humans of Terra need to harmonize their thoughts, and their hearts. A future greater than anything you have ever expected is on the way.

Your good friend  
Jen Han

*(Note from Elena: as Thor Han was relaying the communication with Jen Han, at the moment when Jen Han started commenting these two drawings below, Thor Han's work colleague at the Command Center of his mothership entered the room. My heart pounced; I often tried to communicate with this person but without success; he is very taciturn and private. It is as if he always avoids me, which is frustrating. But he came in and assisted to the whole rest of the transmission staring at a screen where obviously, he could see the scan of this document and connect to our conversation. He spent all this time standing straight, hands crossed behind his lower back, his clear eyes staring at the screen. Silent. This man's name is Shen, he is a science high officer and what fascinates me is this fact: he is a Ummite.*

*We know well that the Ummite are in charge of the exchange of technology blue prints with engineers on Earth. The Emerther and the Alpha Centaurians also do this but the Ummite are leading the project. So having him there was an honor. I wish one day he would communicate with me.)*

## Jen Han Eredyon Session – 04-15-2023

Hello Jen Han my dear Pleiadian friend,

Elena and I planned on doing an instruction for the Terrans on how to effectively clear a crystal before use. Of the 4 main methods identified.

- 1) Pulsed Breath with Intention
- 2) Magnetic Bulk Eraser
- 3) 4096 Hz sound from Tuning Fork
- 4) Coil around crystal with 4096 Hz sine wave.  
(I constructed this one)

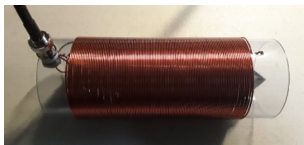

The one method which would be the most practical and simple for the majority of Terrans would be #3 the 4096 Hz sound emanating from a tuning fork.

Before Elena and I recommended this solution, I measured the frequency of common 4096 Hz tuning forks and found the frequency as much as 10 to 15 Hz off resonant frequency. I am assuming in order to resonate with the quartz lattice, that the frequency would need to be more precise in order to be effective. Is this true?

JH (April 15 2023): Thor Han shared with me already Elena's concern regarding this question. Your tuning forks seem to vary in tune with the frequency of the planet and the atmospheric conditions. This is because, and it must only be the reason: the metal they are made of is not appropriate for the use. Steel would approach the results regarding my researches but not very effective as frequency generator, especially when associated with nickel and elinvar (?). Elena told me her tuning forks are in aluminum. I do not believe this is the best metal. Apologies if this point wasn't mentioned in our last conversation. However, the frequency must be precise you understand, to disassemble the particle bounds. When you use frequencies, be exact.

Do you know what is the tolerance or variation is for this frequency to be effective?

JH (April 15 2023): 10 Hz below may be tolerated, but it will not do the best job.

If this is true, then we will need to seek a replacement 4096 Hz sound source. You mentioned that if using a speaker that "The speaker must be perfectly operational without any sound interference-dissonance. Yes, but not the best method."

JH (April 15 2023): not the best method. To me, it is pulsed by breath consciousness with an intention for clearing. Three faces starwise for a six sided crystal. Do not breathe the six, only three clockwise.

A possible tuning fork sound generation replacement comes to mind that can generate at the correct 4096 Hz frequency. Practically everyone on Terra has a mobile phone which can run a program to generate the 4096 Hz sound accurately through it's built in electrodynamic speaker which consists of a magnet circuit and a vibratory diaphragm. The mobile phone speaker could be held close to the crystal.



Could this be a solution for an accurate 4096 Hz sound generation?

JH (April 15 2023): not the best, my friend, but it works, hold it longer next to the crystal. You can place your crystal on your phone but at this condition: it must not be sending harmful electromagnetic radiations...Elena asks if putting the phone in plane mode is Ok... I do not know what is this... Thor Han answered, he says yes this is a sensible thing to do and it is working. He knows best in Terran communications systems then I do.

### **Phryll Generator Construction**

In the construction of the Phryll generator working with my two scientist associates, who have the capability of producing a 3D printed coil form around the crystal to hold the silver and copper wires at the correct angle and spacing, we wanted to confirm the following specifications that you have previously stated...

#### **Central Core Quartz Crystal:**

51.84 and 60.00 terminations

Cut in respect to the c-axis and hexagonal 6 sided core of the lattice

Can be tapered or straight

Size determines capacity

Minimum 3:1 length to width ratio for Phryll generation (longer works well for Phryll production)

Mounted vertically with 60 degree termination up

JH (April 15 2023): this is correct. I see you are well occupied.

#### **Toroidal Coil configuration:**

Copper coil wound starwise (clockwise)

Silver coil wound counter starwise

The metal purity can be on the low limit 95% so 97% and better is acceptable

The copper and silver coils are at 90 degrees to each other

The copper and silver coils should not electrically make contact with each other

Insulated copper wire with a thin enamel coating can be used to insulate the two coils from each other

A thin electromagnetically transparent cylindrical round coil form can be used to wrap the wires onto

A hexagonal coil form can work but round is better.  
 Coils not to extend into crystal termination areas  
 Coils as close as possible to crystal without touching it  
 Wire can be of a fine gauge wire  
 The more coil turns of wire the more power  
 The spacing between the wires can be equal to twice the diameter of the wire  
 The copper and silver must be the only active metals in the structure  
 JH (April 15 2023): this is correct.

**Toroidal Coil Power:**

The 4096 Hz pulse signal is connected in parallel to the two coils  
 The signal amplitude can be 20 volts which is the most secure rate  
 Higher voltage can be used but only increased progressively from 20 volts up to 60 volts, but do not exceed 60 volts

JH (April 15 2023): this is correct.

Based on the above specifications, this is the current tentative design for the Phryll generator

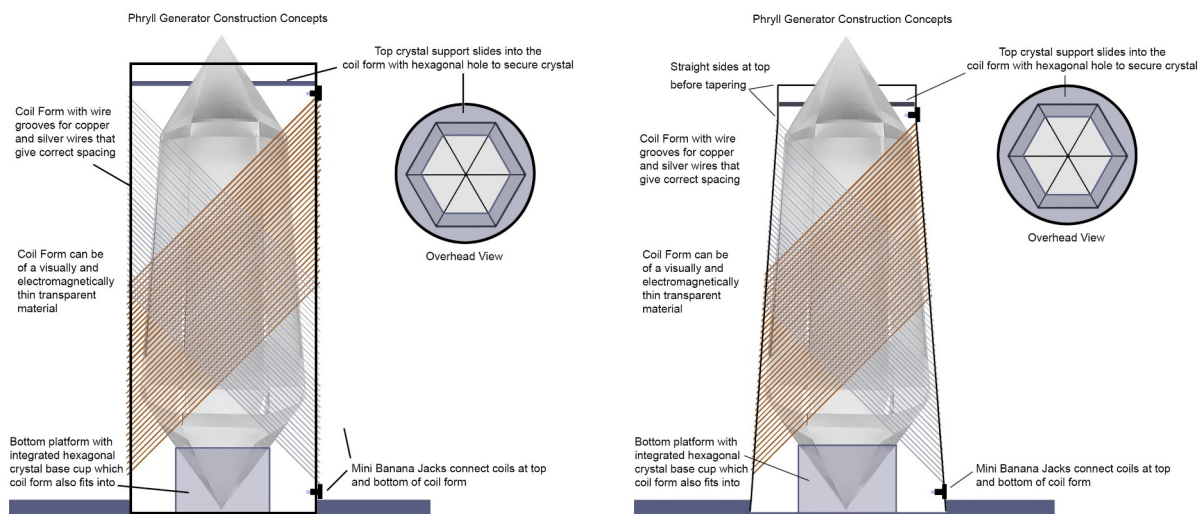

Which coil form would be more effective? The straight on the left or the tapered on the right?

JH (April 15 2023): oh my friend the tapered form. On the first form you have a waste of power.

## Jen Han Eredyon Session – 05-03-2023

### Construction Details:

The coil form will be of an electromagnetically and visually transparent material that will be 3D printed with the wire grooves for the two coils embedded into the coil form.

JH (May 3 2023): Salutations my friends. I first didn't understand your description but it makes sense to me now, that you are correct.

The silver and copper wires will be of a thin 0.33 mm diameter (#28 gauge)

JH (May 3 2023): Elena shared the visual of 0.33 mm diameter on a ruler. This is thin, but it is efficient.

and each wire will be spaced at twice the wire diameter 0.66 mm on each turn.

JH (May 3 2023): correct, this is good.

It is estimated to be approximately 50 turns of silver and 50 turns of copper around the coil form.

JH (May 3 2023): good.

So that the silver and copper wires to not electrically connect, the copper wires will have a thin electromagnetically transparent coating of enamel to keep them from connecting to the silver wires.

JH (May 3 2023): you understand that this point is crucial for keeping the two electromagnetic pulses from not short circuiting and cancelling the perpendicular axis flow, generating the torsion force field. The "enamel" material needs to not alter the electromagnetic field, but I trust your expertise on this material.

The 4096 Hz pulsed signal will be fed in parallel to the two coils which terminate together at the top and bottom where the signal input connectors are located. The top and bottom connectors were chosen instead of only a bottom connector, so that the wires from above do not cross through the field to reach a single bottom connector.

JH (May 3 2023): In a Phryll generator, with a crystal's shaft placed vertically, perpendicularly to the ground, the two wires are connected to the ground, from where they receive the impulse. Under the floor are the pulse generators composed of electromagnets, connected to each of the wires. The flux is sent upwards and harvested at the top of the crystal. The double coil influx of the two serpents as I showed you last time, is how it works. This generates Phryll. The two serpents need to dance towards the sky. If you place a pulse generator connecting a wire in the ground and one connecting the second wire at the top, it will concentrate the production of Phryll towards the inside of the crystal. This has a different effect: the crystal will increase its piezoelectric reaction until it sings. It may also levitate. Be very mindful with that.

To hold the crystal in place, a hexagonal base supports the bottom of the crystal, and a disc that slides down into the coil form with a hexagonal hole supports the top of the crystal. I understand that you use anti-gravity to suspend and support your Phryll generator crystals to allow the crystal lattice to vibrate freely. Since the hexagonal surfaces of these two supports makes greater surface area contact with the hexagonal crystal, would less surface area contact, such as using circular bottom and top supports, which would only touch the 6 edges of the crystal, be more conducive for the crystal to vibrate or resonate freely?

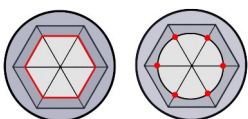

Hexagonal versus Circular holder (Red area indicates surface contact with crystal)

JH (May 3 2023): Visual n.2, less contact with the shaft of the Crystal, it can breathe its pulsed vibration.

Jen Han, I do not know if you are familiar with our understanding in the primitive Terran science which we call “electronics”, and it’s terms and quantities of measurement. In the past exchanges we have only referred to power levels measured in “volts”, such as 20 volts up progressively to 60 volts maximum to power the two coils. Volts are considered to be like pressure, and the volume or current is measured in amperes. Our simple signal generators that Elena and I are using with the silver electrodes at 20 volts, can only output a very low current level of only 0.1 amperes. The thin 0.33 mm diameter wires for the Phryll generator can produce a much greater flux field with large spikes of current measured in amperes, but only if the wires are pulsed using very short duration pulses, this is measured typically in nanoseconds (one millionth of a Terran second of time) otherwise the thin wires would melt instantly.

JH (May 3 2023): I am not familiar with the subtleties of your system of measurements, names and scales, so I leave it to your knowledge in this area.

Would pulsing the 4096 Hz with extremely short pulse widths with a larger amount of current which will generate a large flux field be better, which I am assuming will also allow a greater generation of Phryll? Any recommended values you would suggest?

JH (May 3 2023): Increase the speed of the pulses as you increase the intensity of the electrical current. The intensity is in regard to the size of the crystal. You can powerfully increase the intensity of the pulse for tall generator crystals. For the small ones you are experimenting with, I would be careful and start from low intensity on your scale.

Is it necessary to have the inductance (measured in Henrys) of the copper and silver coils to be closely matched at the same value? Meaning careful cancellation of magnetic field? Or just have an equal number of turns for the copper and silver wires?

JH (May 3 2023): I do not know this scale of values. I am not familiar with. Both pulses should be equal in intensity, but if you alternate the structure of the two pulses it will empower the torsion field. I explain. Start:

Copper 1-0-1-0-1-0

Silver 0-1-0-1-0-1

For Phryll generation testing, my scientist associates with their measuring equipment are using smaller 110 mm length Vogel/Eredyon hexagonal cut crystals. I know you said that the size determines the capacity. Will this smaller size crystal be able to generate enough Phryll to be detected? Or would a larger 150 mm length crystal be required?

JH (May 3 2023): the little ones will generate little Phryll, the larger ones with a greater capacity produce more Phryll. It will be easier to measure.

Jen Han could you please give a good detailed definition of what Phryll actually is?

JH (May 3 2023): Sure. Phryll is the energy created from gravity waves in what you name the ether. These gravity waves are also named compression waves. These waves can be created by gravity or a scalar pulse sufficiently powerful and constant. You will learn that consciousness can produce scalar waves and generate Phryll. I am not speaking about the electrical brainwaves, which are efficient too, but about pure consciousness. Phryll can be present everywhere in the multiverse, and it is efficient when it is activated by a pulse.

Without violating the Prime Directive of course, could you describe how your Phryll generators distribute Phryll wirelessly and how the Phryll is used in various ways, such as electrical power to run all of your various devices on planet Erra?

JH (May 3 2023): We use resonance harvesting. Our devices placed above the crystal generator harvest the Phryll and teleport the Phryll to receptor devices, and these receptor devices transpond the Phryll into a dynamic force that is in turn send either by resonance or by physical wires or tubes, to engines and habitat generators. The habitats and the engines have a crystal that is a receptor and it can store the Phryll. In the reverse dynamics if you will. My sister operates maintenance on one of these, for our small community. It is a pyramidal construction above the valley and it powers by resonance all the habitats.

This should give us enough information to work with to effectively create an operational Phryll generator. This is quite an honor to receive this extremely valuable information from your people which can be used for beneficial purposes for the people on our planet.

In great gratitude for all your help  
Your friend Dan

JH (May 3 2023): Dear Dan, it is my honor. Sometimes, we are destined to certain unexpected missions, life can be surprising, always, even for people who know how the crystal generators work (humor). It is a journey of collaboration with you, and your friends. There is also Thor Han's friend here, who came to attend today's transmission. Shen, he is Ummite. He monitors me now as we are walking you through a new territory. He knows more than me but he doesn't speak much. He is very serious about his work and duties for the Federation. I look forward to know if the answers I gave you are satisfactory.

With love and kindness, your friend,  
Jen Han.

## Jen Han Eredyon Session – 06-08-2023

### Clarifications on Phryll Generator wiring

Thank you Jen Han my dear friend for assisting us in the construction details of the Phryll Generator. I believe we have most of the elements needed for the construction except for some clarification on the correct wiring of the two coils. Hopefully the following wiring illustrations will help to determine the correct method in powering the torsion field correctly into the crystal.

#### Reference:

JH (May 3 2023): In a Phryll generator, with a crystal's shaft placed vertically, perpendicularly to the ground, the two wires are connected to the ground, from where they receive the impulse. Under the floor are the pulse generators composed of electromagnets, connected to each of the wires. The flux is sent upwards and harvested at the top of the crystal. The double coil influx of the two serpents as I showed you last time, is how it works. This generates Phryll. The two serpents need to dance towards the sky. If you place a pulse generator connecting a wire in the ground and one connecting the second wire at the top, it will concentrate the production of Phryll towards the inside of the crystal. This has a different effect: the crystal will increase its piezoelectric reaction until it sings. It may also levitate. Be very mindful with that.

**Jen Han you said “If you place a pulse generator connecting a wire in the ground and one connecting the second wire at the top, it will concentrate the production of Phryll towards the inside of the crystal. This has a different effect” Since the two coils terminate at both the top and bottom of the coil form, in order to make electrical connection to the opposite end of the coil at the top, how else can the electrical circuit be completed without connecting to the termination near the top of the coil?**

**I believe the benefit we wish for healthful purposes, would be to send the flux upward for the Phryll to be harvested at the top of the crystal. In feeding the 4096 Hz pulse to both copper and silver coils from the bottom. Which of these 3 wiring configurations are close to being correct?**

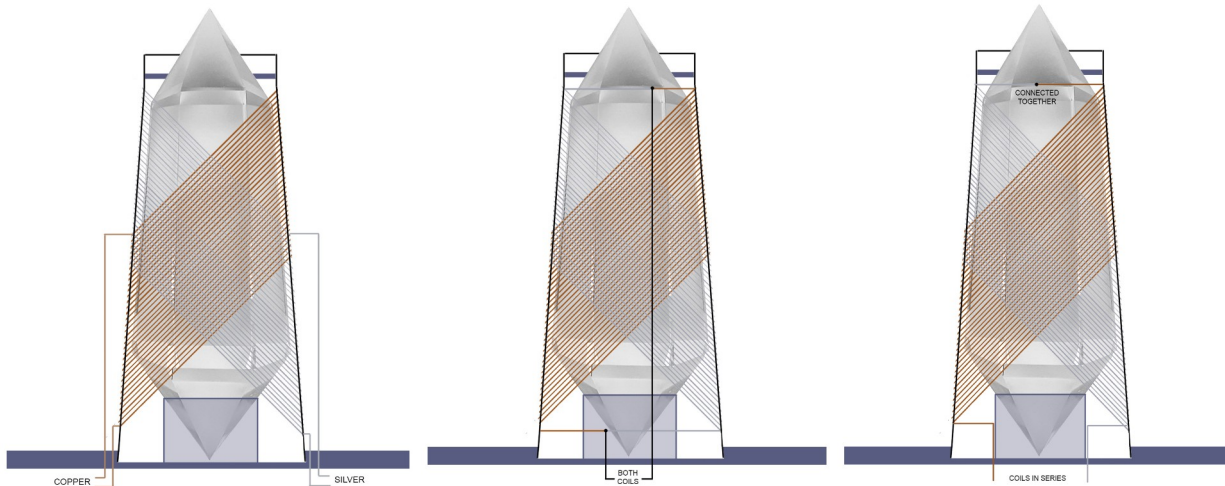

Separated for Alternating Pulse

Parallel Connection

Series Connection

JEN HAN (June 8 2023): The first one, the first one.

E: are you sure? Look well, I am zooming in.

JEN HAN: Yes, yes the first one for the Phryll production is the most efficient. The two following visuals work, they also produce Phryll, but smoothly.

E: Thank you

Jen Han you said “the two wires are connected to the ground, from where they receive the impulse”. If the pulse is alternating between the two coils, then you would need two separate connections to separate the pulses to the two separate coils. Correct?

JEN HAN (June 8 2023): Yes correct. To the former question, add this: Visuals number two and three can be applicable for other purposes. One thing I want to insist upon: the crystal must be perpendicular to the planet’s surface, in alignment with the planet’s center core. This is important regarding the electromagnetic field of the planet.

When referring to the “top” of the coil, since each coil is at a 45 degree tilt angle, the two connections can be tapped at the lowest point in the 45 degree angle tilt. Is this more desirable and what you are referring to?

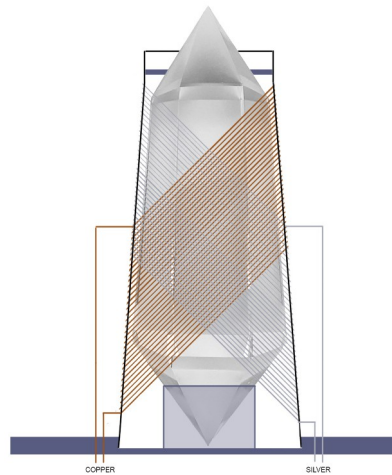

Coil connections at low point of 45 degree angle tilt

JEN HAN (June 8 2023): It is preferable that the wiring stops below the angle of the pyramidion.  
E: Pyramidion= upper point of the crystal?  
JEN HAN: Yes. You understand, a crystal has its proper form dynamics. It needs to be pulsing freely.

When you are referring to “the two wires are connected to the ground”. On our planet we refer electrically to the “ground” as being electrically connected into the planet’s soil. Is this what you are referring to? Would the below diagram represent this connection to the ground which your pulse generators are connected to as a return electrical path with the other end connected to the silver or copper coil?

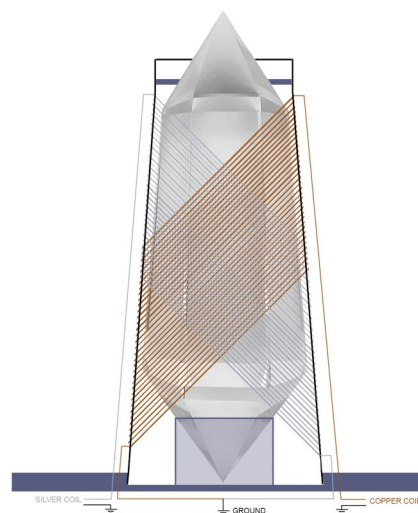

Ground Return Path

JEN HAN (June 8 2023): You have two ways of doing it. This above but also let me show this visual to Elena. That was what it was in Atlaa if you remember well:

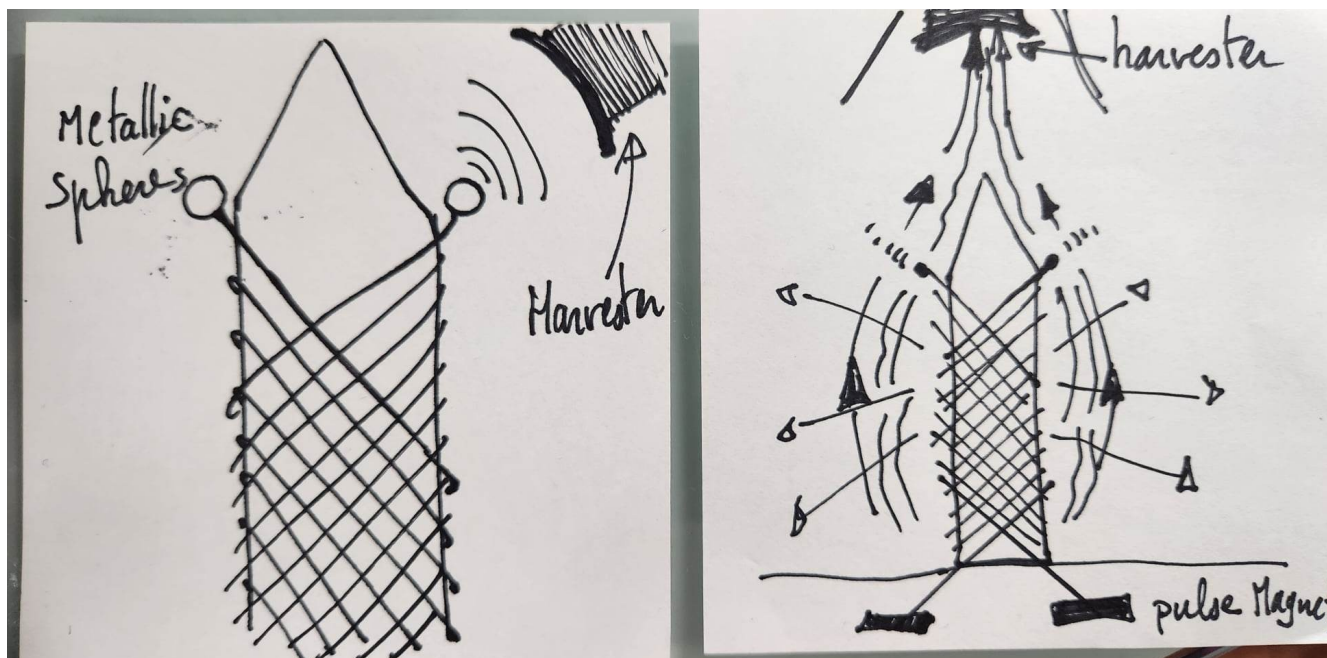

**Reference:**

Would pulsing the 4096 Hz with extremely short pulse widths with a larger amount of current which will generate a large flux field be better, which I am assuming will also allow a greater generation of Phryll? Any recommended values you would suggest?

**JEN HAN (June 8 2023): This depends on the ratio size of your crystal. Start safe and then increase slowly. There is a ratio calculation formula involving these components:**

- crystal height
- crystal width
- quartz frequential clarity
- quartz mineral geographical vibration
- quartz tapering
- quartz number of sides
- geoposition of the crystal during the experiment regarding telluric grid
- planet's electromagnetic field amplitude at that location
- number of coils of the wires
- width of the wires

So you better start safe and increase until you “feel” the crystal is starting to express discomfort. I will repeat again: There isn't you, and the crystal, and the wires, and the planet, and Phryll. No my friend, keep in mind that all is one. Never set aside the consciousness component.

JH (May 3 2023): Increase the speed of the pulses as you increase the intensity of the electrical current. The intensity is in regard to the size of the crystal. You can powerfully increase the intensity of the pulse for tall generator crystals. For the small ones you are experimenting with, I would be careful and start from low intensity on your scale.

**In increasing the “speed” of the pulses, I am assuming to maintain the 4096 Hz frequency and make the pulse quicker or shorter in time duration as the intensity of the electrical current increases. But we will start of course with low intensity settings and see if we can measure any effect from the Phryll generation.**

**JEN HAN (June 8 2023): Yes my friend.**

**Reference:**

Is it necessary to have the inductance (measured in Henrys) of the copper and silver coils to be closely matched at the same value? Meaning careful cancellation of magnetic field? Or just have an equal number of turns for the copper and silver wires?

JH (May 3 2023): I do not know this scale of values. I am not familiar with. Both pulses should be equal in intensity, but if you alternate the structure of the two pulses it will empower the torsion field. I explain. Start:

Copper 1-0-1-0-1-0

Silver 0-1-0-1-0-1

**Reference:**

**Toroidal Coil Power:**

The 4096 Hz pulse signal is connected in parallel to the two coils

JH (April 15 2023): this is correct.

**Is this still correct to connect the coils in parallel? Or is this an alternative method to alternating the pulses to the two coils?**

**JEN HAN (June 8 2023): The targeted result is to create two torsion fields crossing at a 90 angle.**

**Is it more effective to alternate, as you explained, to pulse separately the 4096 Hz pulses between the copper and silver coils?**

**JEN HAN (June 8 2023): If I understand well your question, my answer is: the two wires have each their own pulse generator.**

**4096 Hz Pulse Configurations**

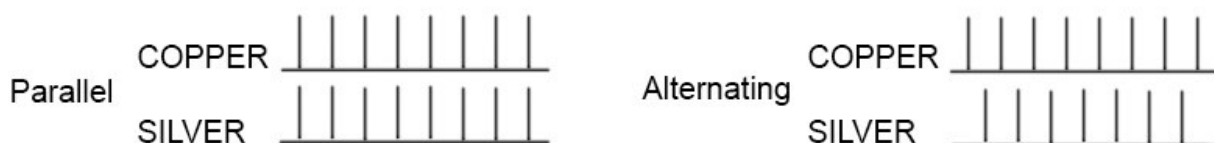

I hope my questions are understandable, thank you again my dear Pleiadian friend Dan

JEN HAN (June 8 2023): Dear Dan, and your colleagues working on this great project: it is my honor to collaborate with you, under the eye of my brother of course, reporting everything of this conversation to his High Command. If I didn't satisfy your friends with my answers, I am always here to help clarify. I am back now in the Ashaara system but I keep contact through my brother. I will visit sometime. I have heard a lot is stirring up on your planet. It is all for the good I know it well. Here in the future of your linear time, we have already made contact and your planet is striving with life, the air has regenerated, it is a whole different future from when this operation had started. And this technology is the common way of living. I salute you with affection, until the next communication.

## Jen Han Eredyon Session – 08-24-2023

Hello my dear friend Jen Han!

**JH: Hi my dear friend!**

I hear you are doing your first terraforming assignment on Mars where you now get to use all your knowledge. How rewarding that must be to see the planet transform!

**JH: I was just talking about this to Elena, here on Tyr it's tough. My first job is not what I expected; I am allocated to the observation and regulation of the micro-organisms that grow on the inner shell of the biodome where I am assigned to. That's not exciting. Here on Mars, because the Selosi brought their own ecosystems, it can at any moment disbalance the perchloric acidity of the ground and cause harm. These micro-organisms produce lithium perchlorate, and at a specific temperature, they generate oxygen, so they release these microbes extremely carefully, not to shock Tyr's ecosystem. You don't see it but there is an ecosystem on Tyr. I would have never allowed these colonies to come and settle here; Tyr is a fragile planet still. Its biosphere was ripped off in the past and it had remained unstable since. Most life forms here have been living underground. There is so much work to do here, and I am only preoccupied with the terraforming operations. The diplomatic and political interactions between all these different groups, the Selosi, the Meton, the Terran military, the Terran colonists, the Tyruu reptilians, the Insectoid clans, and these others arriving soon. In a way, I am tranquil with my microbes crawling under Dome 65T. How can I help you my Terran friend? Hey I can communicate now directly with Elena, they said they are trusting me now! Oh, she asks me to stop talking, she wants to read the questions.**

The two science teams I am working with, are both independently constructing the Crystal Phryll Generator and wanted to make sure they have interpreted everything correctly in the communications by reconfirming a few elements before they proceed any further. The questions are...

**1) How far should the coil winding extend?**

Our understanding of the coil windings, is that they are not to extend into the angled termination area of the crystal. The clarification is whether this is referring to only where the wires crisscross as done in figure **A**, or to keep the loop of the wire from extending further as done in figure **B**.

Which of these windings in relationship to the crystal termination area is correct? **A** or **B** ?

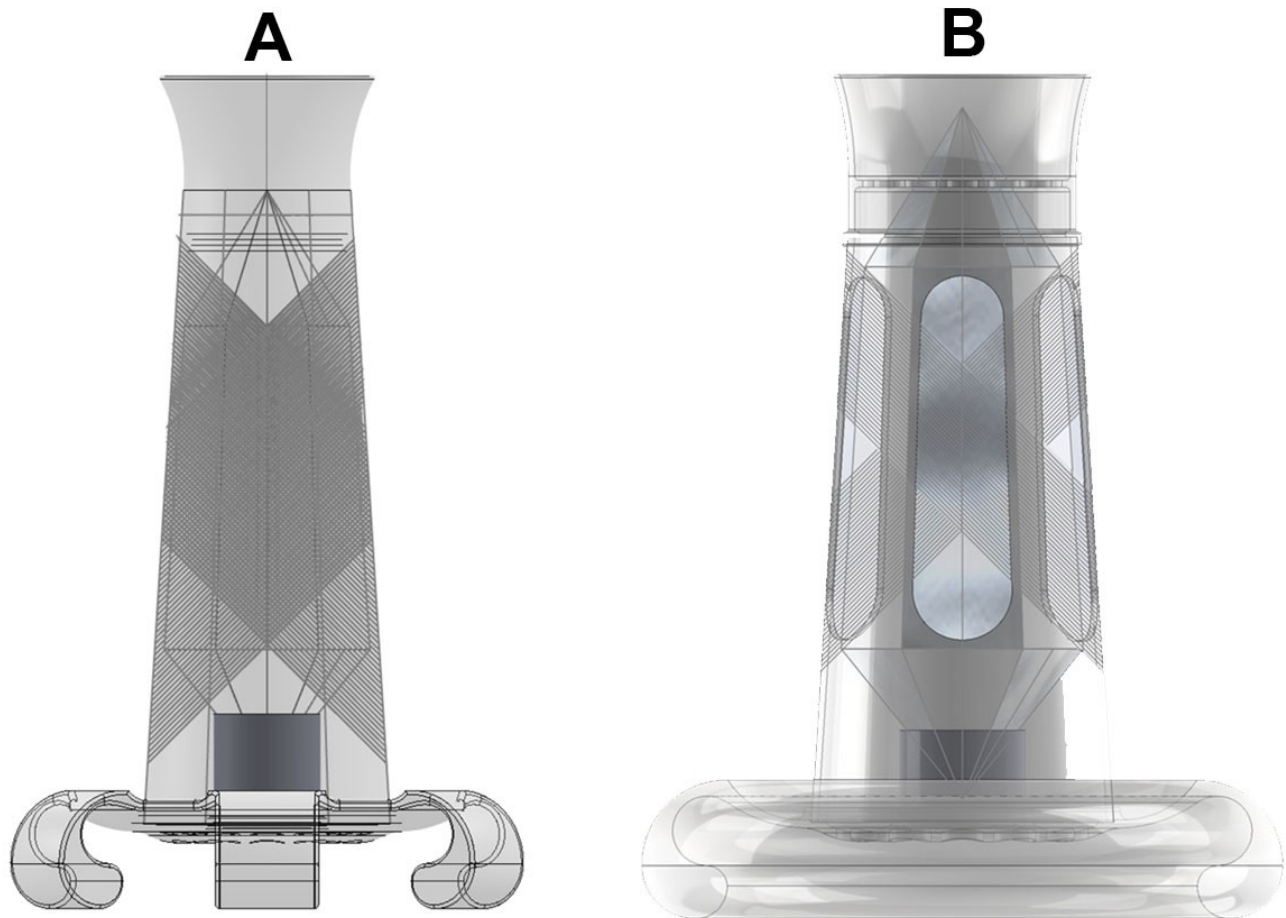

**JH: both works, although “B” works longer unattended. The more you are covering the crystal with the 2 sets of wires, the more powerful the device will be. ‘A’ will produce more Phryll, but you will need to install a regulator to avoid the overload. Points are better when clear, uncovered by the wires, for safety. “A” works well, but “B”’s geometrical ratio is more harmonious with the**

natural flow of the universe, that is why it doesn't overload, although it is less powerful. Remember, harmony. Harmony = flow.

E: What type of regulator are you talking about?

JH: A device using the equation time-energy. When the intensity of the production exceeds a certain limit, the crystal may sing. So this device switches everything off automatically. The great crystals in Atlaa had this system installed.

E: Ok, so "B" then?

JH: They will chose.

## 2) Confirming the pulses are alternating

Reconfirming that two separate independent 4096 Hz pulse generators are connected individually to the copper or silver coil. The generators are not pulsed at the same time, so that they alternate the pulses to each coil, so that both coils are never energized at the same time. In the below illustration, generator A sends a 4096 Hz pulse signal and then generator B sends a 4096 Hz pulse signal that is 180 degrees out of phase with generator A pulses. Is this correct?

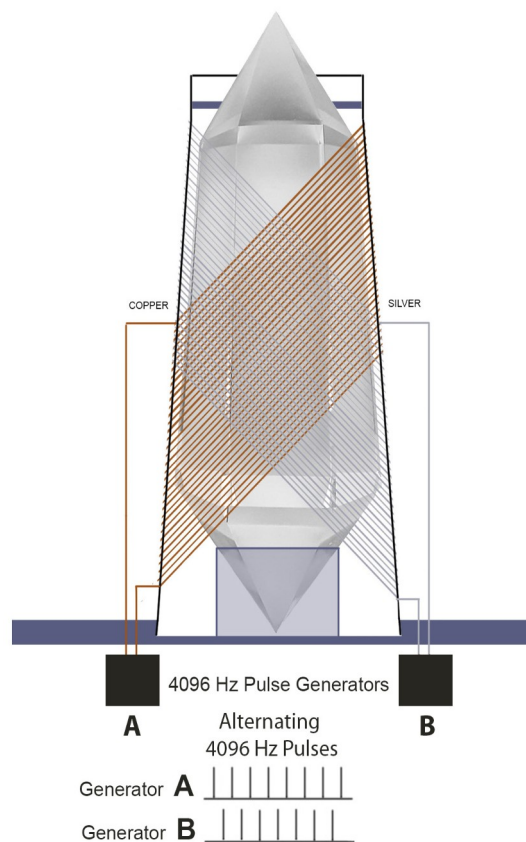

JH: Yes

### 3) Does the Phryll Generator Crystal sing?

You stated previously that there is a concern of the crystal “singing” in regards to the previous configuration of the crystal with silver electrodes and 20 Hz pulse for opening the eye of the crystal. With the configuration of the Crystal Phryll generator is there the same concern of the crystal “singing”?

**JH: oh yes there can be, as I stated yesterday, in our last communication. The crystal can sing if there is an overload. It can even cancel mass.**

### 4) Procedure for shutting down when singing is detected

If singing can be an issue, both science team engineers plan to put a microphone to detect the singing sound of the crystal to shut down the power and then restart. If this is a concern with the Phryll generator, they want to know what audio frequency range the crystal may sing at for it’s detection? And at the point of singing, should they have the power either reduced significantly or have it completely shut down, and then how long should one wait before re-establishing power?

**JH: cut signal generator. I don’t know the exact frequency. The devices we use shut down the signal automatically when there is an overload. It stops singing when you cut the signal. You can restart a few seconds later.**

**E: They need to know, because they want it to be safe, you understand?**

**JH: I understand.**

**E: How do you measure the overload? When do you know it is happening?**

**JH: It is happening when the signal overloads by resonance. The eye of the crystal activates its singularity, as a vortex. When the crystal is saturated, it will reflect back the signal on a higher frequency, like a mirror if you will. The interferometry between the incoming and outgoing signals creates the sound. Because of the wires around the crystal, the torsion field will activate in cancelling the mass of the crystal. At that point anything can happen. I suggest to proceed by sequences, for example a series of four sequences, and then stop for the half of this time duration (the time of two sequences). This is completely safe. They proceeded like this in Atlaa.**

**E: you refer regularly to Atlaa, did you live there?**

**JH: I may have briefly visited (laughs)**

**E: So many mysteries, not fair.**

## 5) How critical is the accuracy of the termination angles to it's operation

Due to the crystal source we have, the core crystals that both teams are using have been measured to be as much as 3 to 4 degrees off from the ideal 60.00 and 51.84 termination angles. If this is a critical consideration for the proper functioning of the Phryll generator, do you think the termination angle errors of 3 to 4 degrees will to a large degree detrimentally affect the production of Phryll?

**JH: no, tell them that for this small size of crystal it will not enter in consideration in the fluctuation of the Phryll production.**

I know you said that when you use frequencies “to be exact”. I am assuming the same applies ideally with crystal termination angles in order to properly resonate with the geometry of the tetrahedral fractal matrix that it interfaces with. I am assuming the termination angles of 51.843 and 60.000 degrees need to be as precise as possible for the maximum transponding.

**JH: This is true, in the ideal conditions, but for the size of your crystals it will affect the Phryll production so slightly that it will be non-perceivable.**

The graph below uses as an example the 60 degree termination angle (this applies to the 51.84 termination as well) in relationship to the effectiveness of the crystal transponding as degrees difference from the ideal angle varies. This is not meant as an exact measurement representation, and I know you may not be able to give exact numbers either. My question would be, if there is a variation of the correct angle, would the effectiveness of the crystal transponding be similar to a narrow sharp drop off in resonance or effectiveness as in graph A below, or is there a larger room for error with less precise angles such as graph B?

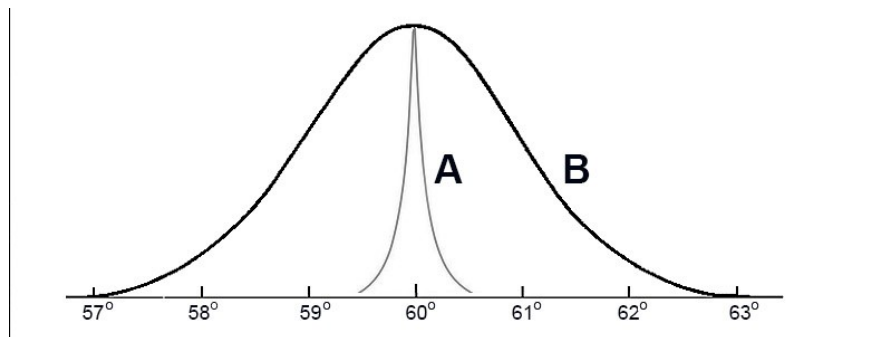

**JH: Dear Dan, for the size of the crystals you are using, the Phryll production's fluctuation in ratio with the angle correction of the crystal, can be compared to B. If you would use a 20Ft high crystal, the ratio would be rather close to A.**

## The termination angles by Terran crystal cutters are not always consistent

The previous crystal used to open the eye of the vortex with the silver electrodes was also several degrees off, which your brother Thor Han checked it and he was able to confirm that it nevertheless did open the vortex eye. So could this be a similar situation with the Phryll generator crystal? If not, it would be good to know this, so that we can acquire a proper replacement crystal with greater termination angle accuracy.

**JH: Dear Dan, I replied just before this last question, it is the same answer as I said.**

This angle issue has inspired us to fabricate a Vogel/Eredyon crystal angle gauge to help the crystal cutters roughly verify the 60.00 and 51.84 termination angles.

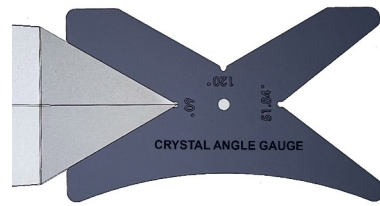

**JH: Oh that is a good idea my friend.**

### 6) For measuring the Phryll generated which of our equipment could most likely measure it?

If we have everything correct, a workable core crystal with the coil form winding around the crystal, and the copper and silver coils are being powered correctly by alternating the 4096 Hz pulses to engage the torsion fields correctly, then the next step is measuring and verifying the Phryll being generated.

The teams would like to know which form of measurement of the following equipment they have at their disposal, would most likely be able to detect and measure the Phryll being generated?

1. Meters for measuring Electric fields, Magnetic fields and Radio frequencies to 10 GHz, Time analysis and frequency analysis
2. Magnetics Measurements DC-1KHz and 1MHz, low field strength, high field, ultra low field, single axis and 3 axis (XYZ)
3. Geiger counter and scintillator instruments for radiation detection, X Rays to Gamma
4. Infrared thermal imaging
5. Matched precision oscillators to detect shift in Time Flow
6. Optical measurement from 200 nm to 1800 nanometer wavelength, emission and absorption
7. Scalar/torsion sensors using magnetic potential field, caduceus coils, magnetic capacitor  
Sound measurements, microphones

8. A 52 degree copper cone or pyramid collector above the crystal to measure an accumulated charge

**JH: I am not familiar with your technology, but I can comment as such: anything that measure the electric charge in the photonic field. I would say yes to number 1, 2, try 5, I do not understand 6, 7 yes, 8 is an enlightened suggestion, I suppose the person is familiar with ship propulsion.**

### **7) Should the generation of Phryll be associated with a greater magnetic field strength?**

Of our two science teams A and B, “Team A” has 40 turns of copper and silver completed around the crystal’s coil form as in the below image and is powering the 4096 Hz alternating pulses at a 20 volt level. It is planned next to soon increase the power level incrementally up to the 60 volt level.

In seeking measurement for the indications of Phryll generation, measurements were made with one 4096 Hz pulse being at 0 degrees phase to one coil and the other at 180-degree phase offset to the other coil in order to alternate the pulses between the two coils. A magnetic field measurement was read showing a steady 10-15 milligauss at the output side of the crystal and where the two 40 wind coils crisscross and intersect.

As an experiment, Team A tried running the two pulses instead at once in sync together into both coils and got a large spike in magnetic field energy over 35 milligauss with an oscillation occurring at the point where the two signals are time aligned. Should a greater magnetic field strength be what we are looking for to produce Phryll generation, Team A asks?

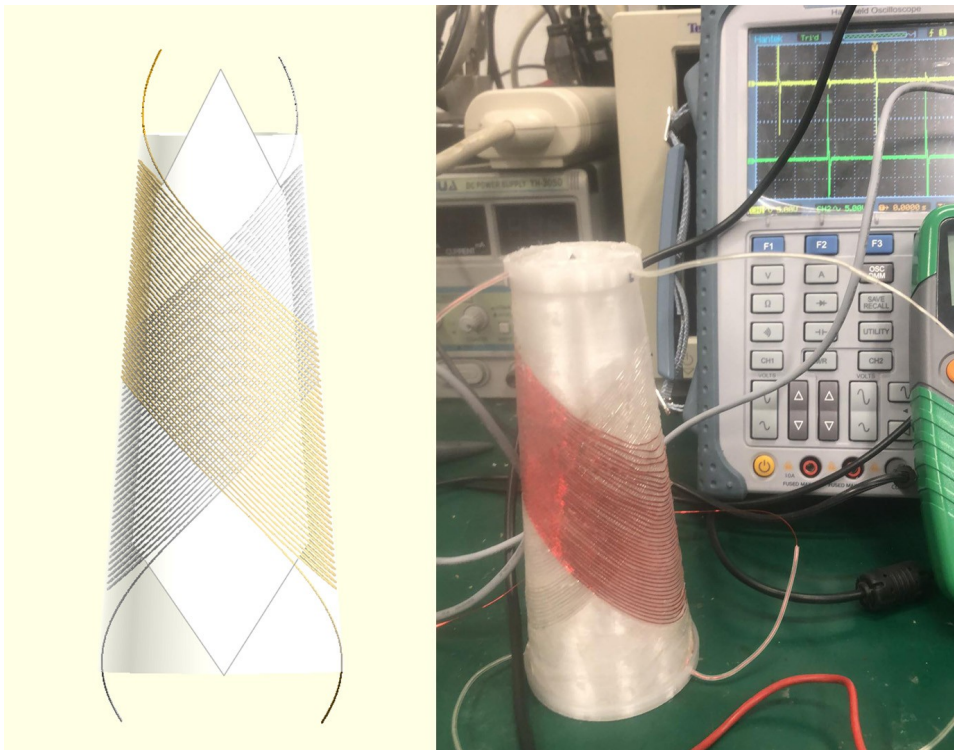

**JH: Yes that is due to the torsion field that is generated. The pulse synchronization of the two coils can fly a craft. Synchronizing signals; The Phryll production will be more consequent for a crystal generator, but you need to do this in sequences for more safety.**

### **8) What is the atomic composition of Phryll, spin state and effect on crystal mass?**

We understand that Phryll is the energy created from gravity waves in what we call ether. "Team A" is wanting to understand the nature of Phryll and has these questions to ask

What is the atomic composition of Phryll by element and number?  
For example Quartz  $\text{SiO}_2$  - Si (1 atom of Silicon)  $\text{O}_2$  (2 atoms of Oxygen)

Do you know what the atomic spin state would be?

Should we be able to detect a change in the weight of the Crystal?  
Or in the weight of a reference mass placed above the crystal in the Phryll beam?

**JH: dear friends, and team A. As I understand your question, I would answer that Phryll has no atomic composition as it is a wave. You should be able to measure a change in the weight of the crystal when it overloads. The mass of the crystal is not affected when the Phryll flows through it. Understand: Phryll has no mass. When overloading a crystal, the Phryll starts to modify the frequency rate in the atomic bonds of the quartz. Same when it loads within your body: it modifies matter by reorganizing the atomic bonds in what is dissonant. That is how you say in a simpler way that Phryll can heal. Phryll has no affect on the atoms properly speaking, but on the frequency between them.**

## Jen Han Eredyon Session – 08-26-2023

Electroculture antenna question:

**An antenna design to collect Phryll for plant growth enhancement**

**JH: The following sequence of questions is part of the terraforming work on Mars so I will discuss this tomorrow.**

**(Aug 26 2023):**

**JH: I am enjoying greatly our conversation my dear sister. Salute my dear friend Dan for me please. I am looking forward to meet with him. May this day comes forth soon. What are today's questions?**

While the team is working on the Crystal Phryll Generator, I have a question for you regarding an effective method of Phryll harvesting for plant growth enhancement. The Terrans call this practice "ElectroCulture"

**JH: We use a similar technology in the biodomes here. With water. We are producing water directly from Tyr's natural elements. How can I help?**

### **Electroculture Definition:**

"Electroculture is a simple method of applying atmospheric electricity to significantly increase plant growth. Using basic materials like copper wire (and/or magnets and crystals) to vitalize the soil and increase yields by 100% - 300%. It also eliminates the need for fertilizer and pesticides, explained that "it is not electricity as we know it, but a breath of energy... which stimulates and increases the fertility of the soil."

Jen Han could these copper wire antennas that collect energy from high up in the air mounted on a tall mast connected with a wire down into the earth near the plants, be feeding the plants the Phryll energy collected in the atmosphere?

### A basic illustration

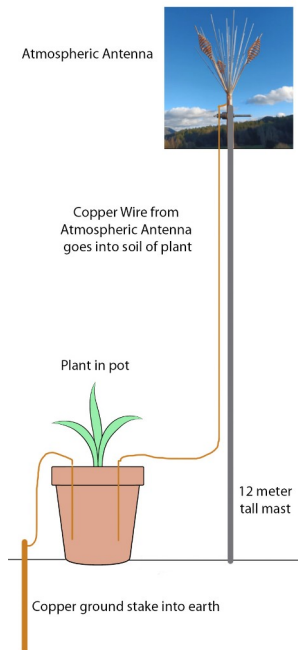

If so, could you recommend an efficient antenna design to more effectively collect this energy to enhance the plant growth? Such as what geometry for example to form with the copper wire, what materials to use for the antenna or other considerations?

I ask this because I am experimenting with my garden with this approach and I greatly appreciate your advanced planetary knowledge of what ways I could enhance the growth of the plants in this manner.

Some example illustrations of various types of ElectroCulture antennas used by the Terrans...

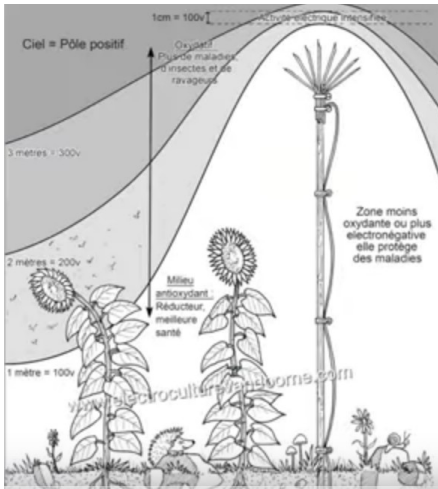

Web Ref <https://www.electroculture.life>

French <https://www.electroculturevandoorne.com>

Thank you my dear friend for answering all these questions and sharing your knowledge. I hope your terraforming operations on Mars are going well. Our crystal classes are being well received and appreciated by the Terrans. I look forward to the day we can meet and be able to experience a beautiful future on our planet Terra. I am in great gratitude for Elena providing these communications, to you, your brother Thor Han and the Galactic Federation of Worlds for assisting us in helping to make it so!  
Your Terran friend Dan

**JH: Dear friend Dan, it is not the electricity properly speaking, that these installations harvest in the atmosphere, but the Phryll. Phryll is present everywhere in the universe in a dormant state, and activated by pulse waves. Copper is a natural material that combined with atmospheric water can attract and convey Phryll. The reason is the pulsation rate of the natural frequency of copper, which gets a response from Phryll, it resonates with it naturally, it is a question of pulse speed rate between the copper atoms. You know that the world you see is only an infinite range of vibrations. All in the universe is vibrations. The different speed rates of the vibration within the atoms of matter create materials, colors, feelings...**

**So, what to do to improve these Terran Phryll atmospheric harvesting installations: add geometry. It will magnify and increase the pulse of the copper antennae. What geometry: the fractal tri-dimensional designs such as the Fibonacci sequence. Lozenges. Grid spheres.**

**Copper always works with water. In the Phryll generators your teams are building, the quartz replaces water, and of course in a more efficient way. The frequency of water is in fractal ratio resonance to the frequency of quartz and in a greater measure, that of light.**

**Observe the butterflies: the beat of their wings activates the Phryll that is in the air. Birds, insects, especially bees. Bees always know where the Phryll goes; they follow its invisible pathways. The planetary ground's magnetism, also, generates Phryll, because it pulses at a certain frequency that you call Schuman Resonance, but what is special is that it does it in a grid, so it is a generator. Did you know that all these things are happening in the very air you breathe?**

**The very air you breathe is traversed by pulsations, frequencies, and it is filled with Phryll. Anything that sends a pulse into the ether wakes up the Phryll. This is what copper harvests. Now try this, if it is in your capacity: One copper antenna and one silver antennae, and in-between, what you call magic will happen. The distance between them is not a concern. Your heart will calculate this distance because your heart is a computer interfaced with the geometry of the universe. Silver on its own does not harvest Phryll, but it serves as antipode to copper in the harvesting process. These are the white and red serpents that you know. All was encoded for you, Terrans, to find out about the technologies our people used on Terra a long time ago.**

**On Tyr, we use two different metals but of similar vibration as copper and silver. We have similar installations in the biodomes but they are on a geometrical pattern. Oh I wish I could send you visuals. The installation you have is already very good. Play around, create currents in the Phryll, you will have great amusement and, "thryll" !**

**I am available for any further questions. My good friend Dan from Terra, it is my pleasure to converse with you. Tell me next time how the work on the generators is advancing with your teams.**

## Jen Han Eredyon Session – 09-10-2023

Elena establishing communications with Jen Han on Mars (Tyr):

Elena: I have only the sound, can you hear me?

Jen Han: I can hear you, wait I will switch the visual on.

E: How do you do that? Do you do it with the implant or using technology?

JH: Technology. Wait, right, can you see me?

E: Yes! What's the brown stains on your face?

JH: Oh I was outside, strong winds here, it lifts the soil in dirt storms.

E: Do you mean... that you can breathe outside?

JH: Yes, we can when the winds are here. There are areas on Tyr where you can breathe. We are moving the atmosphere, creating currents in it, but not too brutal; by stages.

E: Yesterday you couldn't take the communication with me because you were in a horrendous and violent storm, but you were wearing an environmental suit.

JH: That was for the dirt. You can't breathe in a powerful dirt storm, only you can breathe when the wind is from sublayers of the atmosphere; it moves the breathable air without the dirt; then you can.

E: Ok thank you. I will still have to interview you on absolutely everything you are doing on Mars. Let's go now to the questions from Dan:

Hello Jen Han my friend,

Your last information was very helpful to our team in the construction of the Crystal Phryll Generator and we are moving forward with almost all the elements completed and should be measuring the generation of the Phryll soon.

JH: glad to hear from you, and from the research teams.

While awaiting these elements on that project to complete, I want to thank you for your insights on how to optimize a Phryll collection antenna for enhanced plant growth for my garden project. From the concepts you shared, I understand that...

You recommended using fractal tri-dimensional designs to magnify the effects of the copper antenna

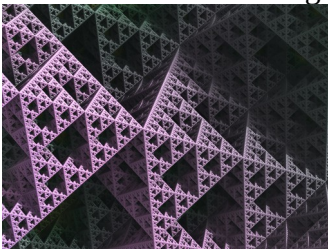

### Fibonacci sequence

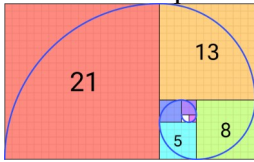

### Lozenges

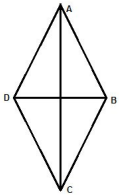

### Grid spheres

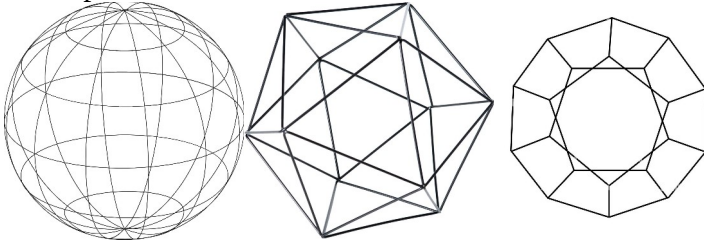

Are these above images representative of what you were referring to?

JH: Yes, they are. Use wiring to reproduce these geometrical shapes.

You said that in using one copper antenna and one silver antenna, that in-between them what we call magic will happen.

That a pulse into the ether is required to awaken the dormant Phryll which the copper resonates with to attract and convey the Phryll from atmospheric water or quartz to harvest. The silver element does not harvest Phryll, but it serves as antipode to the copper element in the harvesting process.

Based on this information you shared, I am attempting to construct something for harvesting the Phryll and conveying it into the plants for enhanced growth

The Crystal Phryll Generator would obviously be the most efficient way of generating Phryll for the plants, but may be out of the construction capabilities of many Terrans at this point in time.

My question is, can the required pulse to awaken the Phryll from the ether be provided by a non-electronic means, or is an electronic pulse an essential element required for the copper to harvest?

JH: you do not need any electronic generated pulse. The frequency of the planetary field, that you call gravity, is a pulse in itself. It awakens Phryll. If you have a copper antenna you can harvest it; it will diffuse it around the antenna and also broadcast it into the soil, where it is plugged. If you add a silver antenna, it will create a current between the both poles, you may assimilate this installation as an amplifier of the atmospheric Phryll. Anything that is located between the two antennae will be energized by this current.

If an electronic pulse is required, would this pulse be electrically applied to the copper antenna and at what frequency would be most effective? 4096 Hz?

JH: You can do that

The copper and silver elements represent opposites in nature, and it is the interaction of these opposites, which I am assuming is the “magic” that generates the Phryll.

JH: Yes my friend

The primitive Terran materials I have to work with is a lot of copper wire in varying diameters and a number of pure silver coins (1 oz round 37mm and 2mm thick). Silver on our planet is expensive in trading compared to copper, but I can acquire silver wire if needed as well. A signal generator could serve to supply a pulse signal. Also have some raw nature quartz crystals or even a small 11mm long Vogel/Eredyon cut crystal. With these basic elements could something be constructed to harvest the Phryll for the plants?

JH: I just learned how challenging it is on your planet to acquire silver metal. A crystal coil with a thin silver wire, the crystal amplifies the signal, can be used instead of a plain silver pole, which I understand is dear for you to acquire.

Grateful as always for your sharing your knowledge with us. Elena and I are continuing to give ongoing classes on crystal technology and we may have some questions in that area to share with the Terrans, and our Crystal Phryll Generator team may have some as well in the days ahead.

JH: Always here to answer your question at the best of my knowledge. The Federation trusts me now to speak with you without monitoring.

Thank you my friend on Tyr  
Dan

## Jen Han Eredyon Session – 09-19-2023

Hello Jen Han my friend

Regarding the detection of Phryll generation, we have been delayed in awaiting the delivery of our manufactured coil form for our larger 153 millimeter length crystal. While awaiting, in order to save time and perform some tests, our science team member Kent Noonan has fabricated a coil formation around a smaller 101 millimeter length crystal to test for any indication of Phryll production with our various measurement equipment.

Photo of small crystal test set up

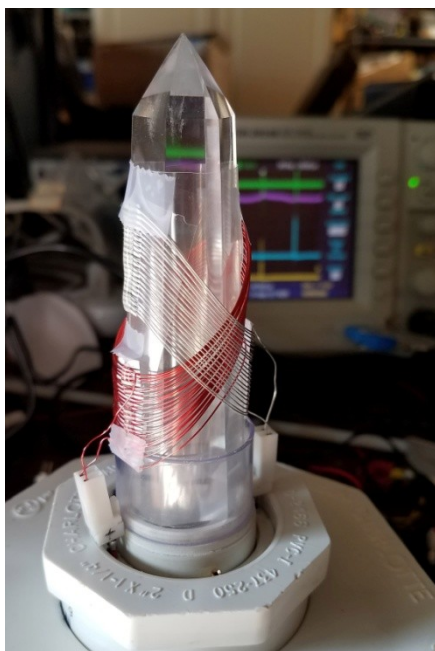

JEN HAN (Sept 20/2023): Make sure that the wires coil with parallel interspace and do not touch. One of the conditions necessary to generate a torsion field. The great crystal generators have the coil wrapped from bottom to top, but the smaller crystal work well such as in this visual.

In our previous exchange you commented on a list of various forms of Terran measurement equipment.

Reference:

Jen Han: I am not familiar with your technology, but I can comment as such: anything that measure the electric charge in the photonic field. I would say yes to number 1, 2, try 5, I do not understand 6, 7 yes, 8 is an enlightened suggestion, I suppose the person is familiar with ship propulsion.

1. Meters for measuring Electric fields, Magnetic fields and Radio frequencies to 10 GHz, Time analysis and frequency analysis
2. Magnetics Measurements DC-1KHz and 1MHz, low field strength, high field, ultra low field, single axis and 3 axis (XYZ)
3. Geiger counter and scintillator instruments for radiation detection, X Rays to Gamma

4. Infrared thermal imaging
  5. Matched precision oscillators to detect shift in Time Flow
  6. Optical measurement from 200 nm to 1800 nanometer wavelength, emission and absorption
  7. Scalar/torsion sensors using magnetic potential field, caduceus coils, magnetic capacitor  
Sound measurements, microphones
  8. A 52 degree copper cone or pyramid collector above the crystal to measure an accumulated charge
- Our team electronics engineer (Kent) has performed the following tests with this temporary set up with the smaller crystal and has the following questions. Note, that at the bottom of this document is a reference to our units of measurement here on Terra you can refer to if needed. I have asked Kent to put forth his questions and test results that follow...

## TESTS

The 101 mm crystal being used in this smaller test set up is based on Vogel/Eredyon specifications and the silver and copper coils are being alternately pulsed at 4096 Hz up to levels of 60 volts. The coils are constructed with 21 turns each of copper and silver wound clockwise and counter-clockwise respectively. The pulse is limited in time to 1.3 microseconds (microseconds =  $1/1,000,000$  second,  $10 E-6$ ) so that current is limited to 3 amperes when flowing through the inductance of the coil. Current increases in 1.3 microseconds, and decreases in 30 microseconds. Some variations have been devised to reduce the current decrease time to less than 1 microsecond.

We have performed the following tests and obtained these results:

**Test #1** A precision charge amplifier was connected to the tip of a sheet metal copper cone with 51.84 degree angle and base diameter of 2 inches, and suspended at various heights above the crystal. Signals were observed with no clear relationship with the crystal stimulation. It is likely the fields from the driving circuit were influencing the outcome. There was no large current flow from the cone, only minute amounts. Where would the current flow from and to? How would Phryll move electric current in this case? Through the wire to earth ground? From top to bottom of the crystal? From inside to outside, or top to bottom of the cone? The amplifier can detect down to about  $1 E-14$  amperes, or about 2000 electrons per second. Moderate current pulses are seen at the transition time of the coil driving pulses, lasting several microseconds. It is expected that these are interference from electronic fields.



JEN HAN (Sept 20/2023): Try a pyramidal shape on the exact same ratio as the upper point of the crystal.

**Test #2** A coil was constructed with caduceus form , clockwise and counterclockwise turns at right angles to each other (as done in the crystal coils with copper and silver), with over 1000 strands of wire in each branch (see photo). The windings go from base to tip, then return back to the base in the same direction. This should cancel inductance and provide sensitivity to scalar and longitudinal waves. There should be little response to magnetic fields and no response with DC (direct current or steady state fields) The output current of this coil was connected to an amplifier that converts current to voltage to be easily measured. Signals are observed that seem anomalous, seeming to relate to the geomagnetic field and also the crystal charge. The signals vary widely and crystal related indications are confusing. Clear patterns are observed in the vicinity of the coils and change based on location, but also with position of the hands and orientation relative to geomagnetic north. DC outputs are observed dependent on which direction it is pointed. This appears to indicate the Phryll is interacting with Earth magnetic field.

Can you describe the shape of Phryll fields around the crystal/coils and indicate which direction flow or force might be observed?

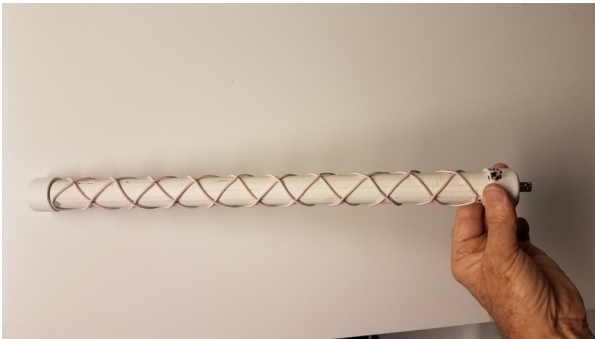

JEN HAN (Sept 20/2023): I will show a holographic projection to Elena and she will draw:

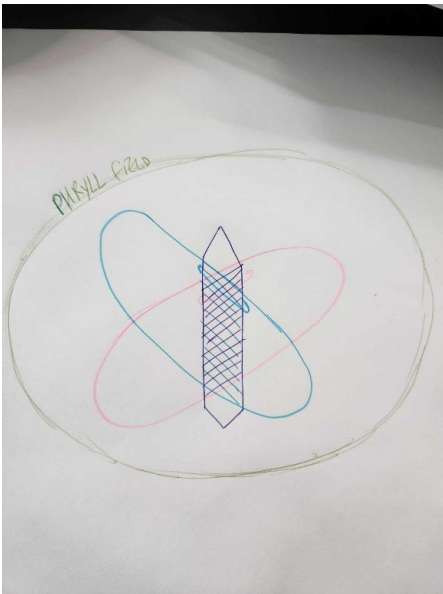

### Test #3

A microphone is embedded in the base support of the crystal holder. The output of the microphone is monitored continuously to check for singing. No patterns of sound have been observed.

JEN HAN (Sept 20/2023): The singing occurs only if there is an overload.

### Test #4

Magnetic field measurements – A small single axis magnetic field detector with very fast time response was used to measure magnetic fields around the coils and crystal. Field gradients are observed as expected due to the current flowing through the coils. Variations due to field cancellation of different positions were seen, as expected. We did not attempt to detect magnetic fields with the coils turned off. Should there be a magnetic component of Phryll that can be observed?

JEN HAN (Sept 20/2023): Phryll is detected by the bending of the particles of light and the force waves that compress the void in regular pulsing waves.

How would we distinguish that from normal electromagnetic fields we are generating?

JEN HAN (Sept 20/2023): This is different. Phryll's energy field doesn't originate from electrical current but compression waves. Do you own devices able to measure compression waves traversing the void, or should I say, non-void= space?

Would these fields be strong or weak?

JEN HAN (Sept 20/2023): This depends on the size and capacity of the crystal.

Would they be time varying in sync with the coil current, or steady state unipolar in the direction of the crystal axis?

JEN HAN (Sept 20/2023): Phryll pulses in resonance with the electrical frequency, but results in a unified field of radiant energy.

We have more sensitive detectors and 3-axis types, as well as super sensitive induction coil with amplifier. Could it be detected by a piece of iron held by hand in the vicinity of the crystal?

JEN HAN (Sept 20/2023): I am not sure I can answer this question with certainty.

**Q.** Are we having these results due to the test crystal being too small or not enough coil turns of wire?

JEN HAN (Sept 20/2023): The crystal big generators are covered from bottom to top, yes with more length of coil, but many wires are spaced wider. Different methods giving different results, for multiple purposes.

**Q.** To make sure there is no misunderstanding on the coil winding directions. Please check that the coil winding direction is correct in this photo. The copper (clockwise) and silver (counter-clockwise) looking from the top of the crystal downward.



JEN HAN (Sept 20/2023): This seems correct to me.

**Q.** You stated that “anything that measure the electric charge in the photonic field” could detect the Phryll. We are unsure how to interpret this. We have attempted to measure charge around the crystal. We have not attempted to measure light around the crystal, we do not see it. If light is expected, is it weak, or is it beyond our visual perception range? Could photonic field be interpreted as radio waves? Is it useful to take a long exposure photograph to achieve very low light levels?

JEN HAN (Sept 20/2023): The photonic field as I could describe it, if the frequency of light, not particles. Frequency fields are wave impulses, and light is made of waves, same as gravity, although gravity and light do not occur in the same mechanical pattern of propagation. Gravity creates Phryll, Phryll creates light. It is difficult for me to understand the technology of your measuring devices, so I hope I could be of any help here.

Dan here, hopefully this was not too much of an overload for Elena going into so many technical details. Greatly appreciate your guidance my friend so that we can finally say that we have detected the presence of the Phryll being generated.

Your friend on Terra, Dan

JEN HAN (Sept 20/2023): Thank you my dear friend Dan, I hope you reach out to some results. You should soon.

With my friendship, Jen Han.

## **Description of Terran units and definitions.**

(Terran terms compiled by science team member Kent Noonan)

It would be helpful for clear communication to establish technical terms which are understood by both you (Jen Han) and us. We would be pleased to learn your units and make conversions in advance regarding our questions. It would also help us to understand and be more confident in our interpretation of the physics. Our Terran definitions of units of measurement for reference:

Do you use base 10 number system? Exponential notation? 1000 can be written as  $10^3$  or 10 E3. .001 can be written as  $10^{-3}$  or 10 E-3. If not, can you provide some details of your number system and notation for large and small numbers? Can you provide some conversion details between your units of time and ours? What units do you use for time?

Electric Charge is the property of matter that generates force from the presence of electrons or protons. Electrons are considered negative charge, and  $6.24 \times 10^{18}$  electrons produces one Coulomb of charge. (6,240,000,000,000,000 electrons)

Electric Current refers to the FLOW of electric charge. One Coulomb of charge flowing in a wire in one second is defined as one ampere of current.

Resistance is a property of matter that opposes the flow of current.

Magnetic field describes the force generated outside a wire when current flows through it. One Gauss of magnetic force is the result of one ampere of current flowing through one loop or turn of wire. Other units are often used such as the Tesla, but these units can be converted to the easily understood unit.

Energy is a measure of work done when electric current flows through resistance. One Joule of energy work is done when one Ampere of current flows through one Ohm of resistance.

Power is the transfer of energy over time. One Watt is the power consumed when one Joule of energy is produced in one second.

Voltage is the potential difference between two points of a conductor when one ampere of current dissipates one watt of power.

Light is understood to be electromagnetic waves in quantized amounts, and can be observed as either waves or particles we call photons. Electromagnetic waves are also observed at lower frequencies we call radio waves. They are inherently the same, but greatly different in frequency. Red light has a wavelength of around 650-700 nanometers,  $10^{-9}$  meters. Violet light has a wavelength of about 400 nanometers. In our lab, we can measure light from 200nm to 1800nm (ultraviolet to infrared) easily, more in the long wavelength range if needed. Our measurement capability includes analyzing emitted light, and the ability to measure light that is absorbed by materials, as well as reflected, scattered, or transformed to other colors. We can produce lasers of various types and make use of optical crystals for nonlinear transformations. We can also analyze polarization of light.

## Jen Han Eredyon Session – 10-09-2023

Hello Jen Han my dear friend,

This month in a few days, our science team will join myself and Elena at a conference on the Terran date of the October 20<sup>th</sup> and we will be presenting the Phryll Generator Crystal to the people of Terra for the first time. Our primary objective is to demonstrate to the Terrans that the Phryll Generator from the information you have shared is generating Phryll to be used for beneficial purposes and that it can be detected and measured.

Our team has been attempting to discover various possible methods to “measure the compression waves traversing the void” in order to indicate the presence of Phryll.

We should first confirm with you that the Phryll generator we have constructed is correct and should be operational and producing Phryll.

### 1) Confirming the requirements for the generation of Phryll:

- 1) Crystal cut in alignment with hexagonal core with 52/60 terminations +/- 3 degrees
- 2) 40 turns of copper (starwise) and silver (counter-starwise) of 0.33 millimeters in diameter
- 3) The two coils are pulsed alternately at the following..

Frequency 4096.00 Hz

Pulse Width 1 to 4 microseconds

Voltage Range 20 to 60 volts

Current Range 0.2 to 2 amperes

Copper and Silver coils relative to crystal position

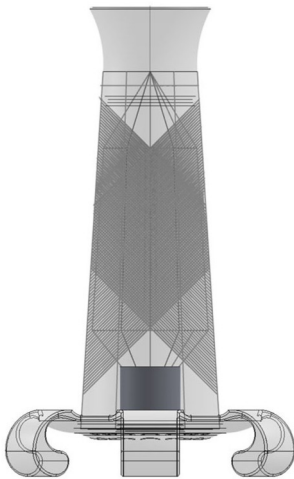

Jen Han: Yes this seems correct. It should power small habitat.

## 2) Regarding pulse wave formation powering the coils:

These questions on pulse formation are addressing how to best produce the torsion fields required. This is not commonly understood on Terra, and it would be helpful to have information about what electromagnetic behaviors that occur in order to enhance torsion field production.

The following readings of Voltage, Current and Magnetic Field were taken as seen on display

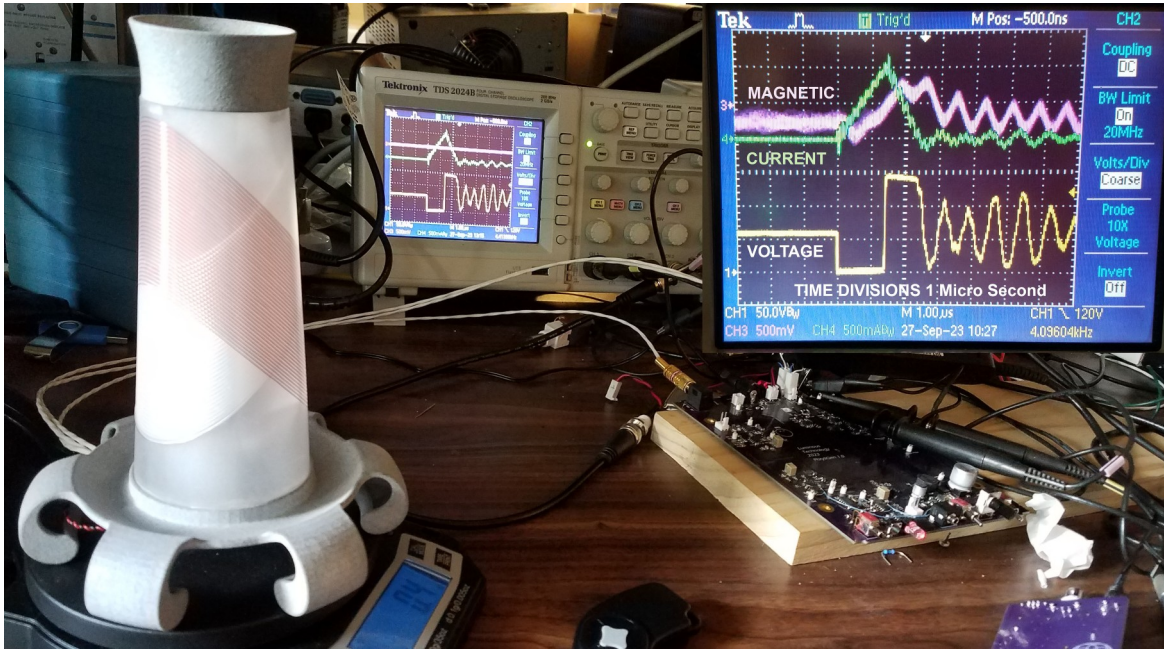

4096 Hz Pulse formation on the above display shows a sharp trailing edge of the voltage. We then did a variation of the pulse formation shown below with a sharper leading edge rather than on the trailing edge of the voltage pulse. The current in the below pulse sustains for 100 microseconds instead of 0.6 microseconds as in the above.

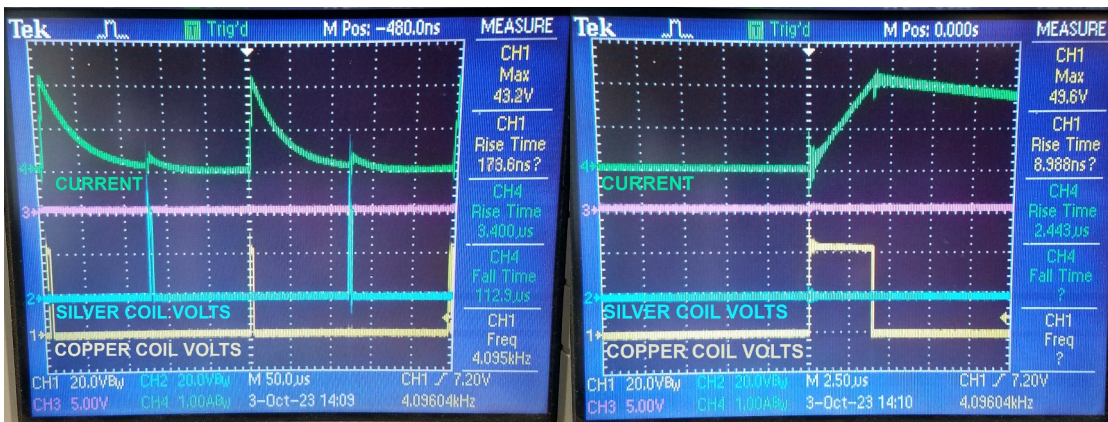

Shown above at 50 microsecond divisions of time and zoomed in at 2.5 microseconds of time

We have been adjusting parameters to produce significant current, 1 to 2 amps to drive the electromagnetic fields. The waveforms shown indicate faster or slower current on the decaying edge with changes in the circuit. Is there a preferred symmetry or asymmetry in rising and falling time?

Jen Han: If I understood well your question, and I am not misled on what rise time and fall time are, so a perfect symmetry in these measurements is not required, as you are measuring different elements producing different electromagnetic fields.

Is it more effective to have much narrower pulse time at the expense of lower current? We can make the pulse 10 times (or more) faster or slower relatively easy. This would result in 10 times lower or higher current because of the coil magnetic field behavior. Some of your answers indicate faster is better. The voltage rise time is already less than 10 billionths of a second, and the duration is 1 to 4 millionths of a second. We can easily change that duration to almost any amount.

Can you comment on the what the most effective pulse waveform should be?

Jen Han: Try increasing the pulse speed, and the duration of the sequences. It should give different results.

### 3) Regarding the pyramidal shaped collector:

JEN HAN (Sept 20/2023): Try a pyramidal shape on the exact same ratio as the upper point of the crystal.

Reference image of cone collector

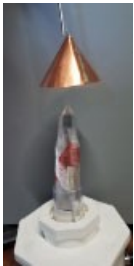

Is the below image what you are referring to for the pyramidal shape copper collector of 60 degrees with 6 sides? Or 60 degree pyramid with 4 sides? Does the size matter? Is copper recommended, or another material for an effective collector?

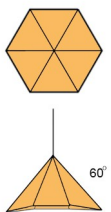

Jen Han: The pyramid generators are shaped as a pyramid with an exact ratio to the crystal's geometry, on a 51.52 to 52 angle slope in Terran measurements, and a harvesting cap, or pyramidion, starting about one fifth of the total height. This cap will harvest the Phryll that has been kept locked inside of the pyramid room. On Terra, copper would be a right metal.

#### 4) Regarding allowing the crystal to “breathe” you stated that...

Jen Han (03-01-2023): It is better wires not touching and without insulation, but the type of insulation you are mentioning is suitable. **I insist on letting the coils breathe.** You are not producing electricity but Phryll. Space between the coils matter. Even with insulating material. Our way is without insulating material, with breathing coils. The **crystal also must breathe, that is important.** Light must flow.

Jen Han (05-03-2023): Visual n.2, less contact with the shaft of the Crystal, **it can breathe its pulsed vibration.**

When referring to allowing the crystal to breathe, are you referring to the mechanical structure of the crystal lattice to oscillate freely without restriction, or are you saying that there needs to be more air flow around the crystal?

Jen Han: I am referring to allowing the crystal to oscillate freely, not to air flow.

The crystal is placed on an empty cylinder at the bottom and maintained in vertical position with a ring at the top according to your recommendations.

May the pressure of the top ring prevent generation of Phryll?

Should the crystal be able to vibrate in the top ring or can it be maintained fixed?

The top ring is currently a plain ring. Should it allow air to pass through it?

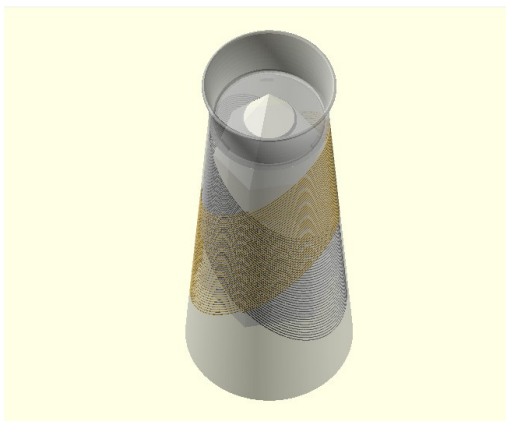

Jen Han:

I recommend that nothing touches the crystal directly, it needs to oscillate even if you don't see it.

### 5) Regarding a chip in the crystal tip affecting Phryll generation:

Somehow in the handling of the crystal a very small chip approximately 1 millimeter in size occurred in the tip of the 60 degree upper termination. Would this adversely effect the Phryll generation?

Jen Han: I do not think so in this case. It should not affect the Phryll generation.

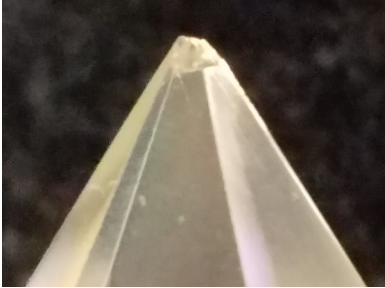

### 6) Possible remote verification of Phryll being generated?

As a last resort before the conference, if we have constructed the Phryll Generator properly, and we are unable as of yet to detect and measure the Phryll being generated with our equipment, I wanted to ask if the following is possible? Since your brother Thor Han previously was able to remotely verify that the vortex was able to be opened in the crystals that Elena and I were pulsing with compression waves at 20 Hz with the silver electrodes, then we were wondering if it is also possible that the Phryll Generator could be also remotely checked to see that it is operational and generating the Phryll correctly? If so, do I need to move it to my location where I am being scanning?

Jen Han: my dear friend, I would be only able to record measurements if Elena is physically near the device. You understand, I would do this via her implant as it can interface here with my equipment. That is how I get visuals on screen from her here, on Tyr. Through her implant. Thor Han proceeds the same, with her device, also they have a telepathic link proper and unique to them. Which I don't have with her. Oona can also record these measurements by direct telepathy with Elena, as they are of the same matrix soul group. The best able to perform a remote recording I believe would be Oona, but Elena must ask her, I don't have her direct contact link.

Thank you Jen Han as always for being so gracious to answer all of our questions to assist us in bringing this crystal technology to be used for beneficial purposes for the people of Terra

Your friend Dan

Jen Han: I was sad that your devices could not measure the Phryll production, and I wish I could be of better assistance. I am tightly monitored here. I rejoice that you and Elena will meet on your planet, that will be a very nice moment of friendship, I wish I was here. One day maybe you come to Tyr before I am allowed to come to Terra!

With my affection, Jen Han Eredyon your red dust covered friend living in a pressurized bubble.



**To be continued...**

## Jen Han Eredyon Session – 11-07-2023

**NOTE 11-14-2023:** This session of questions submitted were originally written on 10-12-2023 prior to the conference presentation of the Phryll generator to our planet on 10-22-2023, hence the different dates and sequence of discussion.

JH 11-07-2023: I have watched the recorded transmission of the presentation in your symposium, that my brother transmitted to me. It was good, excellent, and I am so proud of all the team, all of them who worked on this project, even those who weren't present. I have been made aware of the discrepancies of opinions within the team, and the splitting to compare different methodologies. In the end, it worked out well and you made your first Phryll generator, congratulations!

E(Elena): I never told you all these details, who did?

JH: Thor Han, of course.

E: He always knows more than he pretends.

JH: He spies on you and your communications sometimes (*laughs*)

E: How are you Jen Han?

JH: Oh great, I have been upgraded!

E: Oh brilliant! Congratulations in turn, to you! What happened? Are you still in that Selosi experimental biodome?

JH: No, guess where, Aries Prime!

E: Aries Prime? Woahh what are you doing there?

JH: Well it is more interesting now for me, they are teaching me about different types of environmental change operations, I am working as one of the assistants to great scientists. Some scientists are from Terra. Working on the atmospheric domain, operating on the air masses' movements. Everything here is so slow; this planet is full of life already and all changes need to be made finely, in accordance with the requirements of the local life forms.

E: You said some scientists are from Terra?

JH: It's a mixed team.

E: What nationality on Terra?

JH: Ehm Russian and American.

E: How many of them?

JH: Six.

E: Ok, I have questions from our friend Dan, are you ready?

JH: I am!

Hello Jen Han my dear red dust covered friend,  
(he laughed)

**JH 11-07-2023: Hello my very dear friend Dan from Terra! I am not covered in red dust anymore as I was promoted in the labs on Aries Prime. Work is more interesting now, I am getting into the scientific calculations and I interact with great specialists. I saw the visioning of your presentation and it filled my chest with pride. Congratulations!**

**Dan 11-14-2023: Dear Jen Han, Glad to hear of your promotion! It has been my greatest honor and to know it was viewed favorably by you is greatly fulfilling. Thank you my dear friend!**

I love your humor from your pressurized dome bubble!  
I too reside inside of a dome that is on top of a hill on Terra.



**JH: This is an incredible view of your habitat, Thor Han showed it to me already. I love the similarity between our bubbles! At least your is not pressurized and dusty.**

At least you are safe there on Tyr, and when our planet becomes safe, I very much look forward to meeting you someday my dear friend. In the few days we have left before we all meet at the conference, which will be wonderful that Elena and I will get to meet for the first time, our science team will continue to attempt the detection of the Phryll being generated, since you confirmed that we have all of the basic elements correct in what we have constructed to be able to generate Phryll.

**Dan 11-14-2023: Elena and I got to meet for the first time. It was a joyful event!**



**JH: My brother showed to me the presentation and you did me proud.**

**Dan 11-14-2023:**

**Elena shared that she was able to record the presentation via her implant and that it was converted into a compatible holographic format for your viewing on Mars.**

**I am so glad you approved of how we presented the Phryll Generator Crystal technology for the first time to a large Terran audience on our planet. It was truly an honor to present this gift of technology that has been authorized by the Galactic Federation of Worlds. I hope my presentation with my science team of Chris and Kent represented accurately the information which you generously shared. Know that it was received with great enthusiasm by the Terrans.**



Chris Essonne, Kent Noonan and Dan Willis presenting the Phryll Generator to our world

**Confirming the requirements for the generation of Phryll:**

Reference - Jen Han: Yes this seems correct. It should power small habitat.

So a crystal this small (6 inches or 152 mm) on the planet Erra could power the needs of a small habitat? I know power generation is not yet allowed to be done here on Terra, but a small unit like this could provide electrical power as well as the beneficial healing attributes of Phryll to a small habitat?

**JH: yes it can.**

**Dan 11-14-2023:**

**This is reassuring that this size of crystal we are using has the potential to do that!**

**JH: I know from Thor Han's report that Elena was able to interface with Oona, I got the replay of this sequence too.**

**Dan 11-14-2023:**

**So glad you got the replay of Oona sensing the Phryll so we can refer to this result.**

**Originally, it was our hope to scientifically measure the Phryll in order to demonstrate to the Terrans that the Phryll is being generated, but at this stage, we are still seeking to find methods of detection and measurement of the Phryll. As an alternative to verify that it was indeed generating Phryll, Elena asked Oona to come through her pineal vortex and sense the Phryll that was emanating to her hands around the device.**

**Oona's report was that the Phryll field was at a "feeble" level. Then Kent directed a laser light into the top of the crystal and at that moment Elena felt the Phryll field expand considerably.**

**In order to be used for practical beneficial purposes, it is our objective now to optimize the Phryll generation greater than the "feeble" level Oona detected.**

**My question is, do you think the addition of laser light into the crystal is a good method of optimizing the output level?**

## Jen Han Eredyon Session – 02-27-2024

JH (Feb 27 2024): light is always a component of Phryll, in a dormant state. If you add more light to the energy flux, it will increase it slightly.

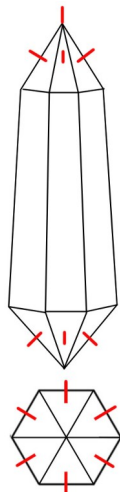

If so, how best to direct the laser beams into the crystal?

Red lines - indicate direction of laser beams into the crystal

- A) Directly into the top in the center of the crystal?
- B) Directly into the bottom in the center of the crystal?
- C) Have 6 lasers directed perpendicularly to the facets at the top?
- D) Have 6 lasers directed perpendicularly to the facets at the bottom?
- E) Other \_\_\_\_\_

JH (Feb 27 2024): the direction of the flux is best to be respected, so I advise beaming light in a concentrate state at the bottom of your crystal, directing upwards. Your answer would be B in your list above.

Instead of coherent laser light, would incoherent light be advised i.e. Visible Red, Infrared Light Emitting Diodes etc. These would have frequency spread approximately 20 to 50 nanometers.

JH: Coherent light but with a pulse. I hope we communicate clearly on that and we understand each other.

Should the addition of an audio frequency key such as 1496 Hz be projected toward the eye of the crystal to enhance the opening of the eye to allow more Phryll to emanate?

JH: this is also something you can do.

[Kent asks]

It is our understanding that by applying very high current short pulses to LEDs, torsion fields are generated in addition to light. Could you speak about this and other alternate methods of crystal stimulation?

**JH: The activation of Phryll by the generation of pump gravity waves or scalar as you name them, creates a torsion field when the crystal's eye opens. You need a pulse, but also consciousness. No machine can do it if there is no consciousness nearby. That is why we always have sentient beings to attend the generators. Their presence gives the last element needed. The operator must have a good symbiotic relationship with the crystal. In more scientific terms: an interface. A mind interface. I feel uncomfortable to share this with some people who could made bad use of this knowledge. Not all scientists work for humanity; some work to serve their interests. You were asking about other stimulations for the crystal: sound. Vibrations that shake the lattice. The sound can be sung, technically generated or the result of hitting the ground around the crystal. Some cultures do that, it sends sound waves, But what you call sound, I need to precise, is not only the noise you perceive with your earn organs; sound is a pulse wave.**

*(at that moment, JH sends me a pulsating sound with a pulse interval of approx. half a second. It ACTUALLY sounds exactly like a spaceship).*

## **Jen Han Eredyon Session – 03-13-2024**

**Could the “feeble” output be from one of our elements not being optimal in these 3 areas below?**

### **The Crystal**

**152 mm length in size**

**Both end terminations are 3 – 4 degrees off ideal 51.84 and 60.00**

**No inclusions are in the area of the eye of the crystal**

**Tiny 1mm chip in the top termination**

**Bottom crystal termination rests on a circular base for minimal inhibiting of physical oscillation**

**There is a remote possibility that the crystal cutter did not adhere to aligning the 6 sides with the hexagonal core of the crystal lattice structure or the c-axis alignment.**

**We have no way of determining the accuracy of the crystal cutter to these requirements as of ye**

**JH (March 13 2024): Your crystal seem good and functional.**

### **The Torsion Field Coils**

**Using 0.33 mm diameter silver and copper wires with 1.19 mm spacing between each winding**

**The copper wire that is used in magnetic circuits has a very thin insulating enamel coating**

**40 turns of copper starwise and 40 turns of silver counter-starwise at 90 degrees to each other**

**The coils extend very little into the top and bottom crystal termination areas**

**The plastic coil form is 1.8 mm thick**

**Wire gullets on the coil form are 0.5 mm wide with silver wire 1.0 mm deep and copper 0.5 mm**

**Wire distance from the crystals surface is 1.68 mm for the silver and 2.18 mm for the copper**

**The material of the plastic coil form around the crystal is electromagnetically transparent**

**An insignificant amount of other metals for electrical connections at the base bottom**

**JH (March 13 2024): No interference should occur in the electromagnetic flow if your coating materials are electromagnetically “transparent”. All your settings seem to me operational.**

### **The Power Source**

**The two coils are pulsed alternately, one being 180 degrees out of phase from the other**

**The frequency of the 4096 Hz pulses has an accuracy resolution of 0.1 Hz**

**The pulse duration length is 1.0 microseconds**

**The amplitude was varied from 20 to 60 volts with around 45 volt range seemed to be optimal**

**JH (March 13 2024): That is where the problem could be location, in the pulse generation. Not in the two points above. Try increasing the pulse intensity.**

**In any of the above component areas, do you see a potential area that could result in a less than optimal Phryll generation?**

[Kent asks]

The limit of 60 volt pulses was given long ago before these construction details were clarified. Is it possible that a new limit, higher or lower, would be better? Under what conditions should we use a different limit? Could the original 60 volt number have been incorrectly calculated, or based on no longer valid assumptions?

JH (March 13 2024): Dear Kent. I would slowly increase the pulse intensity, Volt. Remember to keep your mobile phone devices in another facility. Your phone devices have a detection mechanism for this type of energy frequency. Be very careful you wouldn't like to alert relevant authorities and put your lives at risk. Phones in your car vehicles are a good location.

[Kent asks]

Reference "Jen Han: Try increasing the pulse speed, and the duration of the sequences. It should give different results."

This discussion seems to mean that we should make the voltage pulse duration extremely brief, We can easily use 100 billionths of a second duration. The resulting reduction of magnetic field will not reduce the effectiveness of the stimulation. Is this true?

JH (March 13 2024): I believe it will not.

### Regarding the pyramidal shaped collector:

Reference - Jen Han: The pyramid generators are shaped as a pyramid with an exact ratio to the crystal's geometry, on a 51.52 to 52 angle slope in Terran measurements, and a harvesting cap, or pyramidion, starting about one fifth of the total height. This cap will harvest the Phryll that has been kept locked inside of the pyramid room. On Terra, copper would be a right metal.

To make sure I am interpreting your above statements correctly, I have created a few visuals to refer to:

Are you saying that the Phryll generator crystal needs to be housed inside of a 4 sided 52 degree pyramid with a copper harvesting cap at the top of the pyramid that is 1/5th the pyramid height?

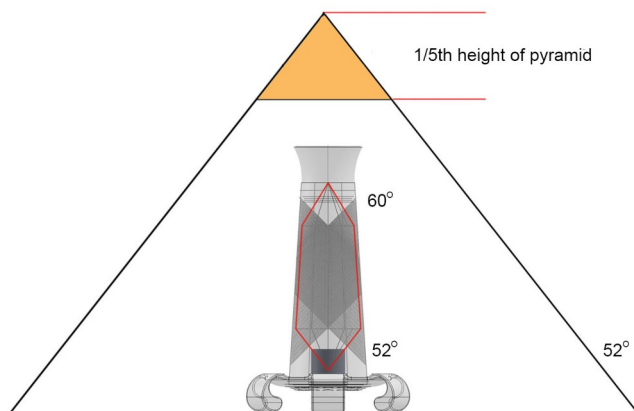

JH: Yes, that is the correct setting

Dan 11-14-2023:

For the construction of this pyramid enclosure, besides the copper capstone, should the sides be open or enclosed and of what type of material would your recommend?

**JH (March 13 2024): For a healing device, no pyramid or open sides pyramid. For Phryll collection, closed sides. That is why we all have these buildings. The material must be a Phryll insulator, a neutral charge material.**

For the size of the copper capstone pyramid in relationship to the size of the crystal, how far should the top of the crystal termination to the top apex of the pyramid be?

**JH (March 13 2024): I do not know this exact measurement because it is a ratio depending on the size of the crystal, but consider it starts at about above the height of the upper tip of the crystal. 1/5 of the crystal length.**

When the crystal is enclosed in this pyramid would the Phryll be able to emanate off of the copper capstone, or how best would the Phryll be extracted?

On planet Erra you said in the countryside settings that a small habitat could use a small replica of the big pyramid generators of the cities, this I understand would provide both the beneficial emanations of Phryll into the habitat environment as well as also transponding wirelessly electrical power to power your various devices via resonance. I understand that the electrical power aspect is not appropriate to be revealed at this time on Terra and for good reason.

**JH (March 13 2024): Dear Dan, interfacing a Phryll generator to a habitat power supply system now, would put your existence in danger at that moment in time in the history of your planet. The technology we use can be named regarding Terra vocabulary as quantum entanglement transfer of energy. Not using linear carrier waves as many of your devices proceed on your planet, but teleportation of information such as harvested, augmented Phryll. This is all I can say regarding my position and concern for you and your friends.**

You stated that the size crystal that we are using could power a small habitat, therefore the “feeble” output that Oona recorded must be due to some element that we are missing. I am wondering if the elements you use to transpond power which are missing in our Phryll generator are required also for efficient Phryll production? In other words, can our Phryll generator produce a practical more robust Phryll output without the electrical power aspect incorporated?

**JH (March 13 2024): Increasing the pulse intensity I think can produce a better measurable result. It is challenging for me to give you precise directives because I am not down there with you, beside you physically, to evaluate the needs, mistakes and improvements. Our generators are enhanced with Khor red crystals but they are not growing on Terra. Mercury ore as I believe you name it, can replace them. Placed around the central crystal, they increase the gravity pulse on the quartz when the torsion field is activated. what increases the Phryll production, and activates its dormant power, is gravity waves. This may be produced by an electrical impulse but also by sound, or any scalar waves. Do not forget: consciousness can power Phryll; thoughts are scalar electrical impulses. Some beings can ignite a Phryll generator by generating the right frequency pulse through their thought impulse.**

That is how some cultures like the Ohorai or Zenate can power and pilot a small ship without any power core and navigation systems; only by interfacing their mind with a central crystal. They move their body to give directions to the ship. I have been told that it is beautiful to watch. But this is not helping you I suppose. Although, remember: consciousness is an element you cannot dismiss. Everything in this universe as an intelligence you can interface with, even Phryll when it has awoken.

[Chris asks]

Is the copper capstone supposed to be electrified by the Phryll ? If yes, will it be alternating charges or charges always positive or always negative ? At which frequency are we supposed to detect any electric signal ? 4096 Hz ? 8192 Hz ? Other ?

Or are you saying that the copper harvesting cap to be suspended above the crystal at 1/5th the height of the crystal?

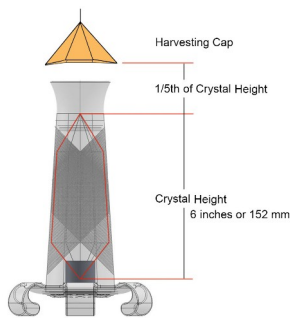

JH: It is harvesting but well in this case you have a loss of energy. The pyramidal structure atop is the right one.

Reference - Jen Han (09-20-2023): Try a pyramidal shape on the exact same ratio as the upper point of the crystal.

JH: Yes. That is the first setting. When I mention ratio it is about the slope's angle.

When you say that the copper harvesting cap to be the exact same ratio as the upper point of the crystal, I am assuming you mean by "ratio" as the same degree angle slope? The upper part of the crystal is as you know 60 degrees and is a hexagonal pyramidion. Which of these two types of copper harvesting caps to be suspended above the crystal would be the correct form? The 6 sided or the 4 sided?

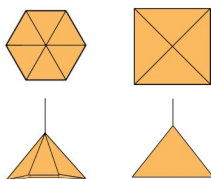

JH: four sided pyramid, my friend, no matter how many faces the crystal has.

Would the slope angle be 60 or 52 degrees?

JH: 52 degrees is right

If it should be 6 sided, should it match physically the size exactly of the crystals upper pyramidion?

**JH: you do not need to match the number of sides of the crystal. The square based pyramid, you understand, is a geomorphic dynamic geometry that interfaces with the geomorphic grid of the planet or whatever device is placed in it. For the big generators, sometimes you can find crystals that are of uneven faces. What matters is to stimulate the eye and create Phryll.**

**Dan 11-14-2023:**

**Understood regarding the 4 sided 52 degree pyramid enclosure. Assuming that it is also required to be aligned with the true north (versus magnetic north) of the planet such as the Great Pyramid in Egypt?**

**So in the big generators the 6 sided crystals can be asymmetrical having uneven faces and still the eye of the crystal is able to be opened? Assuming that the uneven lateral faces are still in alignment with the 3 axes of the hexagonal core of the crystal as in this image?**

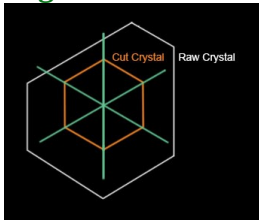

What size harvesting cap would be efficient relative to this size crystal?

**JH: One fifth of the height of the pyramid you place it in.**

**Regarding applying sequencing to avoid crystal saturation (“singing”):**

Reference – Jen Han: The crystal sings. That is why the generators are not pulsed continuously but by periodically, by sequences.

I suggest to proceed by sequences, for example a series of four sequences, and then stop for the half of this time duration (the time of two sequences).

Are we interpreting how to sequence for regulating the power by increasing the time between bursts, or changing the number of pulses in the burst, or?

**JH: Intervals between sequences. Intervals between pulses in one sequence does not vary.**

Dan 11-14-2023: I understand that the generators are not pulsed continuously but by sequences.

Are these sequential pulses of 4 on then pause for half that duration repeated continuously, or are they regulated with a manner of sensing when the crystal is approaching saturation?

[Kent asks]

In our prototype, we have not used “sequences” yet, but continuous 4096 Hertz pulsing without pauses. Yet we have “feeble” results. Is it correct to interpret the discussion of sequences and pause durations as a mode of controlling too much energy, avoiding singing? This would be a dynamic response to the needs of the moment, and not a fixed description of constant operation under all circumstances?

**Time between the bursts:**

Where we sequence the powering of the coils on for a given amount of time for 4 times and then power off for 2 sequences of that given amount of time?

Example 1:

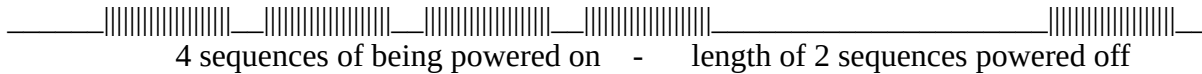

**JH: this one above is the correct one.**

If the sequencing is the time between bursts, is there a way to determine what that length of on time for each burst sequence should be and the length of off time between these burst sequences?

**JH: I do not know the precise answer here, what do you identify as a “burst” ?**

Dan 11-14-2023:

A “burst” can be defined as a series of pulses in a set duration of time.



[Kent says]

We do have a microphone to listen for singing for this purpose to regulate the application of pulses.

**Regarding pulse wave formation powering the coils:**

Reference - Jen Han: If I understood well your question, and I am not misled on what rise time and fall time are, so a perfect symmetry in these measurements is not required, as you are measuring different elements producing different electromagnetic fields.

Jen Han: Try increasing the pulse speed, and the duration of the sequences. It should give different results.

We interpret this to mean to use the shortest duration pulses that are quick and sharp so to speak to activate the Phryll, and not to be concerned about the amount of current flow, magnetic field, or the equal transition timing of begin and end of pulse.

Can you tell us the timing that you typically use for stimulating these coils in a small installation? The time to get from zero to peak voltage? The duration of the pulse?

**JH: I do not have the technical numbers in Terran time scale here but I will ask in the lab.**

**Usually, time is a quarter of the impulse but I am not sure.**

*(back after a few minutes)*

46 Terran milliseconds as a unit, that you can put in sequence for larger range. That is what they say. They are not aware of my participation in this project so it was amusing avoiding their questions.

**Dan 11-14-2023:**

If 46 ms (milliseconds) is considered a unit of sequence if I am understanding correctly? Then with the frequency of 4096 Hz, each pulse would have a period measurement of 0.244140625 milliseconds, which would allow 188.4 pulses to occur within a 46 milliseconds duration of being turned on for that unit of sequence. Is that correct?

If this is so, then for sequencing using this unit of sequence measurement would be...

4096 Hz sequenced 46 ms ON and then 46 ms OFF for 4 times – total time 92 ms x4 = 368 ms Then pause for ½ of that time of 368 ms /2 = 184 ms before repeating the next 4 sequences

Here is a visual example of the spacing between the 4 bursts of pulses if they are equal to the 46 ms length of the burst? Would the spacing between bursts be equal to the length of the burst?



**E: How long does it takes to go from zero to peak voltage?**

**JH: oh it is very quick. You know it as the charge builds up.**

### **Phryll Generator torsion fields and the eye of the crystal**

When the torsion fields of the two coils are activated, do these torsion fields act specifically with the “eye” of the crystal where the two counter rotating vortexes formed by the top and bottom crystal pyramidions meet that form the eye in the convergence of these two vortexes?

**JH: of course the eye of the crystal is activated.**

Is it from the singularity that is opened up in the eye due to the torsion fields piezoelectrically stimulating the crystal lattice structure’s frequency at 4096 Hz and then from the eye center of this singularity vortex that Phryll emanates from?

**JH: correct**

Would you say this is just a more advanced effective method of extracting Phryll from the eye compared to the silver electrodes being pulsed at 20 Hz? Or are they for 2 different functions entirely?

**JH: The silver electrodes open the eye’s vortex to interface consciousness with the grid of the planet. It produces Phryll, but in much smaller quantity. Then it helps you alter the structure of reality.**

**Dan 11-14-2023:**

**This helps to clarify the importance of the eye of the crystal in both of these configurations and their difference in application.**

**The silver electrodes deliver compression waves at 20 Hz for the opening of the eye to be used to alter the structure of reality coupled with consciousness. Due to the opening of the eye, some Phryll emanates, but not as much as the Phryll generator. I do use this periodically to imprint a positive timeline vision into the planetary matrix.**

**The Phryll generator torsion field coils open the eye through the interaction of the torsion field oscillating at the resonant frequency of the quartz crystal of 4096 Hz with both electromagnetic and etheric fields combined to open the eye specifically for generating Phryll.**

**Regarding allowing the crystal to “breathe”:**

Reference - Jen Han: I recommend that nothing touches the crystal directly, it needs to oscillate even if you don't see it.

We do not have anti-gravity capabilities available like you do on your planet. At this time we have the crystal touching the 6 edges at the bottom base while allowing it to oscillate freely at the top of the crystal with nothing touching it. A method to allow it to physically oscillate more freely needs to be developed.

Circular base of crystal

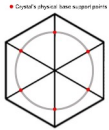

**JH: This is working**

**Dan 11-14-2023: Oh good, since we don't have anti-gravity available to us yet!**

**Possible remote verification of Phryll being generated?**

Reference - Jen Han: my dear friend, I would be only able to record measurements if Elena is physically near the device. You understand, I would do this via her implant as it can interface here with my equipment. That is how I get visuals on screen from her here, on Tyr. Through her implant. Thor Han proceeds the same, with her device, also they have a telepathic link proper and unique to them. Which I don't have with her. Oona can also record these measurements by direct telepathy with Elena, as they are of the same matrix soul group. The best able to perform a remote recording I believe would be Oona, but Elena must ask her, I don't have her direct contact link.

We are also a little sad that we have not been able without our current instrumentation as of yet to detect the Phryll being generated in order to show to the Terrans that what is being generated, although not visible to the eyes of many, that it is indeed real and is being produced.

So it may be that at the conference that we activate the Phryll Generator Crystal in Elena's physical presence in order to check that it is indeed generating Phryll, which we can then tell the conference audience afterward that it has been remotely verified and that we are continuing our research with this incredible gift of crystal technology from your world to ours.

**Dan 11-14-2023: We realize we do not have the luxury of having Elena and Oona available for testing the Phryll output. Therefore, we are earnestly seeking a form of instrumentation in order to detect and quantify the measuring of the Phryll being generated in order to develop the Phryll generator to be practical in applications of the Phryll.**

It is indeed the greatest honor my dear friend!

Your friend Dan on this planet of great need of liberation from the dark elements

**JH: time will come soon my good friend. Soon I promise. I have nothing to do with these operations but my brother tells me great things about the future of Terra. His ability to always remain resilient in hope and certainty for this great future, never ceases to impress me. So I believe him. I admire him, he is a great man. I long for the day when I will be allowed to set foot on your planet my friend, and in the meantime, I wish you all great things in your life.**

**Your friend on Mars.**

**Dan 11-14-2023:**

**It is reassuring hearing this from your wonderful brother Thor Han his views regarding our future timeline on Terra! I know the "disclosure plan" that he delivered to the Earth Alliance must be an incredibly brilliant plan to transition our awareness here on Terra. I too have great hope that we will as a planetary culture pull out of this darker period of our history that has been perpetrated by deceptions, toward a collectively awakened society that could join the Federation. Since as you have stated, that we are all intertwined in our shared planetary matrix, where the light of truth has an exponentially greater effect on all of us than those who wish to deceive and control our perceptions toward their dark agenda. Bringing forth this incredible gift of the Phryll from your world to be able to deliver the benefits to help in restoring health and assist in ending suffering and even to affect plants to grow healthy abundant food on our planet, is indeed a great honor, and I and our science team of Chris and Kent are so grateful to all of your generous assistance helping us realize that.**

**From Terra to Tyr, with affection your friend Dan**

## Jen Han Eredyon Session – 04-18-2024

Future potential Crystal Class questions on science and healing techniques:

My dear friend Jen Han, While we await for a period of a month for Kent to create a new higher power unit for the torsion field coils of the Phryll Generator, of which I will experiment with on plant growth, Elena and I plan to continue with our crystal classes.

The following are related questions if you could be so kind to help us understand this science further...

### CRYSTAL SCIENCE SECTION:

#### Understanding the science of the vortex Eye of the Crystal:

Does the form of a pyramidion termination on the end of the crystal create a spinning vortex within the pyramidion from?

Is this vortex similar to double spiral shown in this Kirlian photograph



Kirlian photograph of Tesla coil inside of a copper pyramid emanating a double spiral from apex

**JH (21/04/2024): Hello my friend Dan from Earth! It's been a while since we haven't communicated. Yes, a pyramidion, as I understand your question, creates a Phryll vortex. Phryll is the etheric energy. The vortex you depict in this visual, kindly transmitted by Elena, is the etheric energy harvested by the pyramidion, the dynamic influx of this harvested energy, the mathematical ratio of the pyramidion, generates a double coiled torsion field. This torsion field bends space and creates a void above the pyramid. This is why ancient pyramid structures on Terra were also signal beacons for ships coming from space. The one in Atlaa was the most powerful of all. It still emits an intermittent pulse because it was recently repaired. Well, considering the age of your planet, by "recently" I mean in the recent past. However, that is not your question. The answer to your question is yes, the visual is correct.**

Is the velocity speed or frequency of this spin determined by the pyramidion angle of inclination?

**JH (21/04/2024): yes, exact. The pyramidion's mathematical ratio.**

The two pyramidion vortexes of 52 (51.843) and 60 degrees on each end of the crystal I understand reflect upon each other like two mirrors. Since there is a difference in the ratio of the 52 and 60 degree angles, they would both have different frequencies of spin when they meet together at the phase conjunction node or eye of the crystal. Since they are counter rotating in opposite directions, does this process of countering and canceling each others spin happen in the phase conjunction node?

**JH (21/04/2024): The two dynamics counter-rotate and meet at the vortex singularity. Because of this counter-rotating dynamics, the vortex is open by phase conjugation of the two frequencies. At the same frequency rate, the dynamics cancel. You need a difference in speed rate to create a dynamic, for the experience to tend toward... perfection, and since nothing in the universe ever reaches the absolute point of perfection, the universe is alive through the dynamics of evolution. So yes, my friend, the two opposing speeds are the application of the law of the universe. Life is a pulse. When you hear your human heart beating, there are two competing pulses that create the dynamics of your heart. Otherwise it would be still. Stillness is death. Making stars is not just about math and geometry, you know, wisdom is also a component. When we play co-creators with Source, wisdom is a primary requirement.**

Is it this process that opens up the vortex eye to create a singularity opening in the holographic matrix?

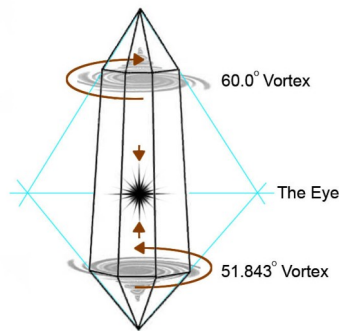

**JH (21/04/2024): As I replied, yes it is.**

**Reference:**

Jen Han: "The singularity is in the vortical center, not metric center. The two triads are not equidistant from the singularity nor symmetric either; **because their ratio**, and their distance from the epicenter, are determined by the different angles of inclination of the two points. It is not a physical node but an infinite singularity, which is different."

Because there is a difference of angle ratio of the two pyramidions and a corresponding difference of velocity of spin, it appears they would not cancel each other out 100%, but rather result in the remaining difference of the two vortexes. Is what is left, a slower spinning vortex from the difference in the velocity speeds of the two vortexes canceling each other to leave a percentage that is the result of the difference in the conjunction of the two vortices?

**JH (21/04/2024): Frequency cancels when the two parameters are rigorously equal.**

What would be the effect if both terminations were not a different ratio and were the same, such as two identical 52 or two 60 degree terminations at the ends? Would the cancellation of the two vortexes be 100% and no opening of the eye would occur when piezoelectrically stimulated?

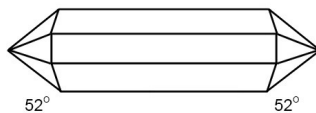

**JH (21/04/2024): There would be no opening of the eye, but of course the piezoelectric field could be stimulated. These crystals are great for healing, but they do not transpond etheric energy.**

**The interaction and balance of receptive and active geometries:**

As you shared earlier, regarding the opposites of nature being vital to the dual nature of Source and that the opposites are always required to work together. It appears the receptive (52) and active (60) degree geometries that meet at the phase conjunction node meets this requirement of the opposites?

**JH (21/04/2024): We are talking about "conflicting" frequency rates that create a dynamic. As I explained earlier, absolute equal forces cancel each other out. In the eternal struggle for balance, an imbalance is the background and always remains as such. When the absolute background is harmonious, the struggle ceases and the universe dies. Absolute entropy begins. Negentropy is the struggle of evolution in the unbalanced background of the universe. In this struggle, there will always be one force above the other, alternating as a dynamic engine. Do you understand? The struggle is necessary.**

In nature there appears to be a joining of these two geometries. The 52 (51.843) degree that acts as a transponder in the matrix has a relationship with the square root of Phi (1.618) and Pentagon geometry

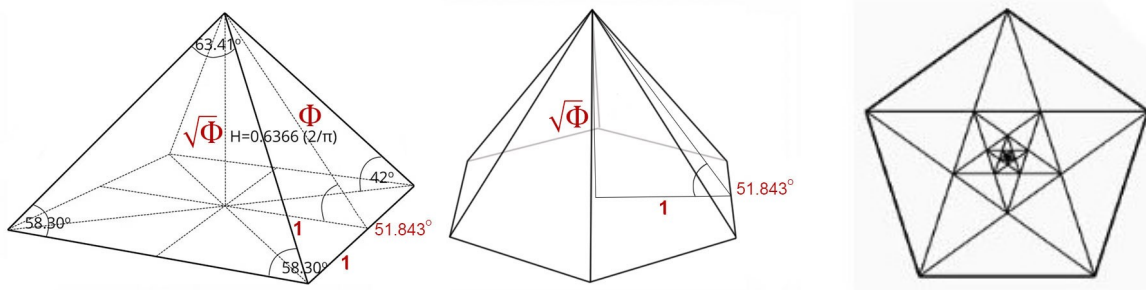

The 60 degree has a relationship with hexagonal / tetrahedral geometry of the holographic matrix.

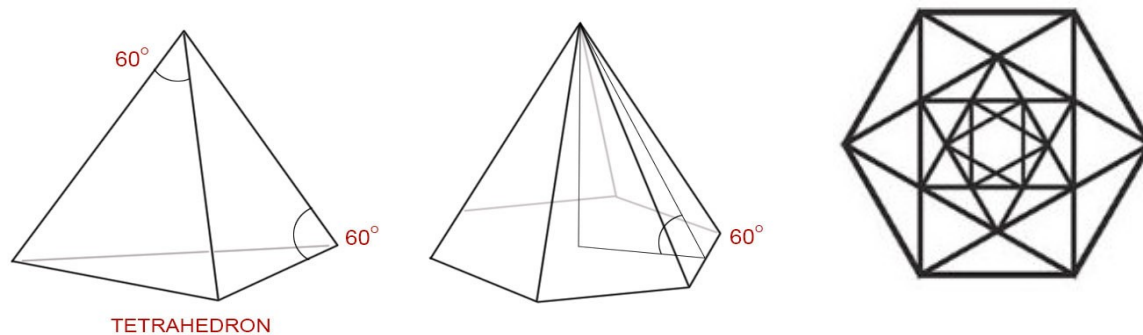

The 60 degree pyramidion termination being the active element to interface with the tetrahedral fractal geometry of the holographic matrix, as represented by the “flower of life” pattern, is based fundamentally on the tetrahedral structure, in which every angle of the tetrahedron is 60 degrees. It appears that based on the principle of form resonance, that this angle allows the crystal to interface and affect the tetrahedral fractal holographic matrix?

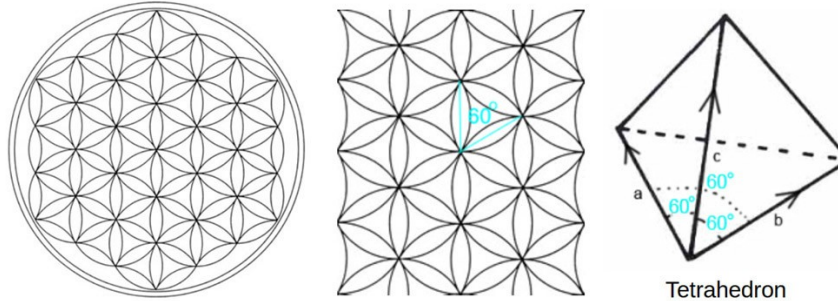

**JH (21/04/2024): This is correct; the 51,843 angle geometry transponds etheric energy and the 60 angle geometry imprints it into the holographic matrix of the universe. This is a great network. This is how we implement etheric energy into physical reality, and this is how the Liminal Geometric Point of Transfluxation allows the intentions of consciousness to imprint a geometric thought pattern.**

**Observations of these two geometries in nature for possible comment and elaboration:**

This combination of receptive (52) and active (60) degrees represented as pentagonal and hexagonal geometries are found throughout nature being combined together.

Such as in our DNA

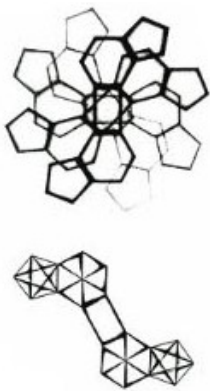

Buckminsterfullerene (C60) is made of hexagons and pentagons to form a spherical carbon allotrope. The dome structure I live in is even made up of this combination as well.



**JH (21/04/2024): This is why you and your beloved companion are at the maximum health potential of your physical body avatars. Recently you both should have died of poisoning but the geomorphic structure of your habitat saved your avatars by energizing your DNA bonds.**

There appears to be an angular 51.84 degree relationship between these geometries in the flower of life.

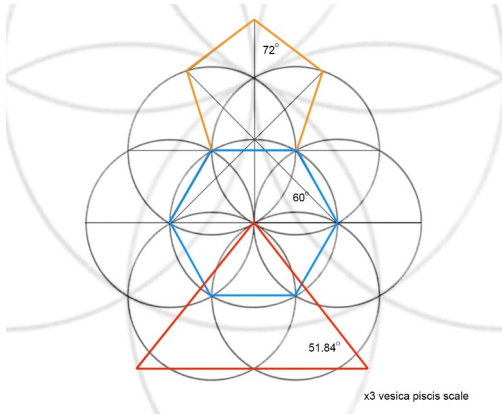

Note interlaced circles within the flower of life represent a hexagonal and pentagonal relationship with 51.84 degree angle relationship with the nested circle radius multiplied by a factor of 3

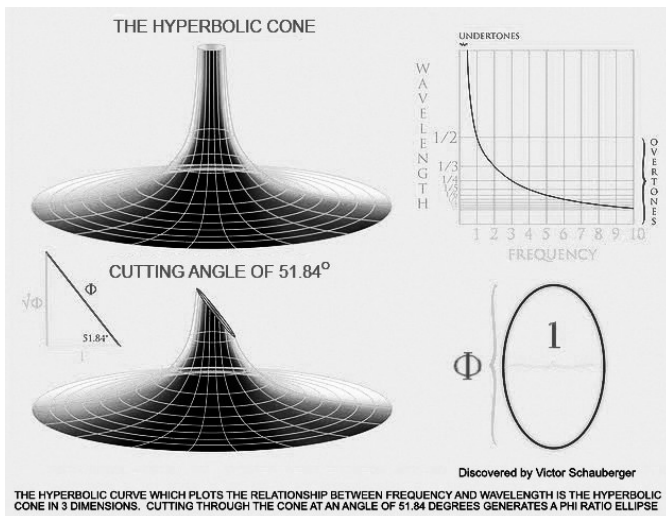

The 51.84 degree angle across the curvature of a hyperbolic cone yields an Phi (1.618) ratio ellipse.

I understand this hyperbolic cone shape represents the curvature of space time, is that correct?

**JH (21/04/2024): I do not use that same mathematics but the visual is correct.**

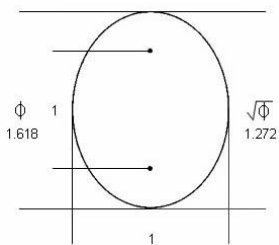

Within the Phi (1.618) ratio ellipse form the 2 foci has this relationship to the square root of Phi (1.272)

Can you elaborate further regarding this combining of hexagons and pentagons and the 51.84 angle in relation to the curvature of the hyperbolic cone to have a more integrative perspective on their relationships?

**JH (21/04/2024): Sure. The visual you present also represents the ratio of the negentropic fractal dynamics of creation, in this universe. Note that there may be slight mathematical variants of this multidimensional formula in other universes. Everything that is created and subject to fractal evolution obeys this multidimensional formula. The ratio of the hexagonal-pentagonal multi-layered blueprint applied to a living organism will produce cellular evolution. Humans, plants, stars, and so on. This ratio is the key to life and is also represented in the blueprint you know as the Flower of Life. Those who understand the secret geometry of the Flower of Life can create universes and life forms to populate them.**

### **Reference statements by Jen Han regarding the void:**

Jen Han: Crystal you name Quartz is in synchronized frequency with Source. So when you stimulate the singularity, you bridge to Source

Jen Han: When the singularity of the vortex is triggered in the crystal, and when it bridges to Source, Phryll comes from it.

Jen Han: Phryll bridges void and matter.

Jen Han: You can program crystals. It especially works when you imprint the programming while the vortex is open.

**JH (21/04/2024): Because of this bi-dynamic ratio relationship.**

The program will not wither in time if it was imprinted into the open vortex.

**JH (21/04/2024): because you use the lattice network of Creation.**

If the program is not imprinted into the vortex, so the programming will wither with time.

Jen Han:

The vortex opened in the crystal, when the eye is activated, can collapse by entanglement two points in space and time.

**JH (21/04/2024): same as time, space has no linearity.**

If you have the coordinates of the receiver, you can exchange information not by sending it but by sharing it, collapsing space-time. You are using hyperspace.

**JH (21/04/2024): and hypertime.**

You know this by the name “quantum”. But it is more than “quantum”; you access the Void. You can connect with any point in space but also in time.

**JH (21/04/2024): That is what the Void is about.**

## Checking understanding of the relationship of Source and the Void with everything:

Is my understanding correct in the following?...

Dan: The fractal holographic matrix consists of an infinite number of dimensions or universes you could say. I am currently aware of being in one of these dimensions. Each dimension has multiple densities that are related to consciousness that emanates from Source, of which we are all a fractal of. The physical reality precipitates from Source which is the origin of all beings and matter.

Source is dual in nature and creative. Since each of us are fractals of source, we are also dual in nature and creative and have the ability to create and change reality.

**JH (21/04/2024): You are correct my friend.**

In our particular dimension of reality, Source projects itself in 12 densities. These could be thought of as harmonics on a scale of frequencies. Each density emanating from Source into physical manifestation has a frequency or rate of oscillation which is associated with a geometry and a level of consciousness.

**JH (21/04/2024 This is where consciousness comes into the equation and how it integrates with the frequency rates of the different densities. Consciousness also vibrates at different speeds and that is how it fits into the scale of densities.**

The higher densities create the lower or sub densities down into physical manifestation. The lower densities, could be visualized symbolically as in this below illustration, are in the outer hub of 12 concentric circles, with the 13th in the center being Source. Therefore what is affected or formed at a higher density affects or precipitates into the formation of the lower densities. The lower densities do not affect or form into the higher densities.

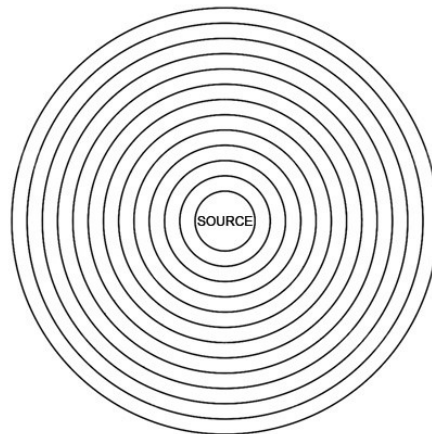

**JH (21/04/2024): That is correct, and how Imana, Source as we call it in my culture, can be depicted as a central sun shining rays of created energy down into its lower realms of creation. Again, nothing is linear in the absolute reality of Source. Frequency rate is linear because it is scalar, but densities are superimposed. The image you created here is correct, but not perfectly representative. This information cannot be represented on a flat two-dimensional support, but only in the multidimensional understanding of the mind, through your consciousness. Imagine...**

**Source is its creation. Source is the multi-universe. It is everywhere in space and everywhere in time. It is not a unique singularity point somewhere at the center of everything, but everything contains it on a cellular level. Within your genetic coding, for example, are the Source vortices that create negentropy. You are the source "in this matter". There is no above and below, there just "is", overlaid in non-linearity and non-temporality. The best blueprint to translate this information into a two-dimensional blueprint is again what you call the Flower of Life. There is a lot to unpack in its geometry. It is not just bubbles. It is the way Source looks and is structured.**

**NOTE FROM ELENA: This is another way of describing the same vision I could access to, when I consulted the Mad-Kahl records on the Nibiru ship, that Source is not an origin dot but that it makes up the whole of creation.**

Source is at a level of perfection, and the universe tends toward this perfection. The higher a being's consciousness goes in density, the more that being resonates more with this perfection and with love.  
**JH (21/04/2024): Yes my friend.**

As conscious beings in this dimension, we evolve through love, as love is connecting pulse between all living things and bridges us from the lower densities into the higher densities closer to Source.

**JH (21/04/2024): because it is the binding medium of the universe.**

The reality we are conscious of is within the density frequency we have evolved to. Whereas in actuality, we are each the totality of all the geometrical frequency harmonics within our dimensional sphere, as is everyone else, as we are all fractals of this one Source, but we are only conscious of the density level we have evolved to.

**JH (21/04/2024): I can confirm**

The infinite number of dimensions can be seen as spheres, each individually with a varying number of densities and the elements of space and time connected together as represented by the "flower of life" as in the below 3 dimensional spherical representation, where the space in-between and outside of these spheres exists an area that is considered to be the void.

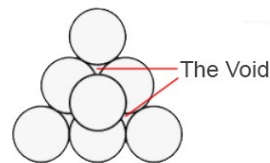
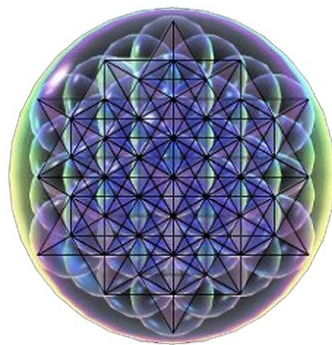

**JH (21/04/2024): the spheres overlap each other so your second visual should be modified accordingly. Above. But the understanding is correct.**

The void operating outside the spheres of dimensions, densities, space and time is connected to all the spheres of dimensions and their various densities. Therefore anything that happens within the void affects everything.

**JH (21/04/2024): correct.**

When consciousness interfaces with the singularity of the void, it can create and imprint a vision of a reality that we can imagine. This is especially effective when you intend love with the visualization imprint, because love allows the imprint to transcend the densities, as love prevents dissonance, as the matrix is in an ordered state of geometrical resonance, of which dissonance can not attune to.

A dissonant pattern does not have the ability resonate, will thus cause the pattern to dissipate in time and will be unable to fully take form in the geometry of the matrix.

The geometry of a quartz crystal is a bridge between all the densities because it's geometrical structure is resonant with the frequencies of all the densities, because it is the fundamental matrix pattern in which all comes into existence.

**JH (21/04/2024): Yes it is.**

It is within this singularity point of the vortex within the crystal that connects to the void, that a conscious thought can be crystallized. When a conscious thought is imprinted into the singularity of the void it will persist into manifestation.

Is this understanding correct?

**JH (21/04/2024): Correct in all points, my friend.**

### **An Emether teaching of geometry and consciousness:**

In the Terran year of 1977, I had an interaction with a very loving being, which Elena later identified as an Emether. This being projected in space a sphere, where the first geometry which formed within the sphere appeared to be a star tetrahedron or Merkabah, then a series of interconnected nested geometries all formed infinitely from that. At this time I didn't even know about platonic solids and how they nest one into the other, so this was new to me and inspired my interest in understanding the relationship of this with quartz crystals.

What the being was conveying was that, within the sphere exists all the geometries, and in our process of evolution we resonate within this sphere at a specific geometry/frequency/density level, and that through love we evolve to the next higher level. At the time, I didn't know if this apparent teaching experience was using this geometry projection as a teaching metaphor or if it had a basis in science. Over the decades I discovered many elements to have somewhat of a basis in science, and I would love to hear your thoughts regarding this experience that made an impact on my life?

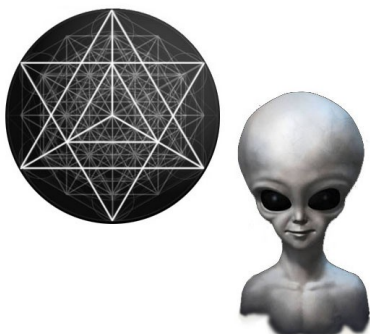

**JH (21/04/2024):** The Emerther are part of the science transfer program to Terra, working with other cultures such as the Ummit and Selosi. In fact, the Emerther initiated it. To help you visualize what I am saying, the three major cultures that have been interacting with the humans of Terra since the 1940's, using your Terran astronomical nomenclature, are Tau Ceti (Emerther-consciousness contact), Wolf 424 (Ummit-personal physical contact), and Alpha Centauri (Selosi-working with Terran governments on technology exchange programs). This Emerther probably followed your development in your temporal imprint and decided to provide you with science. To my friend, this is the science of the universe. He has prepared you, as the science transfer program allows, by modeling your understanding of the universe on a consciousness level, so that when the time comes, you will be able to understand the science that will be given to you to pass on to the Terrans.

### **Piezoelectric stimulation to open the vortex:**

When the vortex singularity opened from stimulation piezoelectrically by either physical or electrical pulses, the vortex opens and your consciousness can be bridged to source and can access the void.

Is the void where the program is written when the vortex is open?

**JH (21/04/2024):** The void allows for imprinting into the grid of the universe from which you are working. It bridges it by accessing the keys of the morphogenetic grid. But it is within the grid of the universe from which you are working that this intention is actually imprinted.

When you stimulate the singularity, you bridge to Source. Is the program written at the level of Source or is it considered to be written in the void?

**JH (21/04/2024):** My answer is above: It is written in the grid structure of your universe, which is where you live and where the intention was created. You can only bridge your intention to other universes or dimensions by accessing the Void, but it will not be effective unless you have an anchor point.

Since the void is connected to everything, is this the means to connect at a higher density at the level of Source from which the program is imprinted?

**JH (21/04/2024):** Yes, correct, if you have the quantum anchor point to do so. Otherwise the program is imprinted within your own Universe lattice structure, but when bridged via the Void, using the vortex of a crystal, it is set forever, as the Void is out of linear time. The "quantum" bridge to Source makes its dynamics remembered forever, and it modifies the negentropic formula of the subject your programming is set to, unless the programming involves a limited duration in time.

Why is it that the singularity vortex only opens when piezoelectrically stimulated?

**JH (21/04/2024):** Because of the pulse.

Does it have to do with the two opposite charge triads of the crystal lattice structure having their balanced charge centers being offset by a pulse?

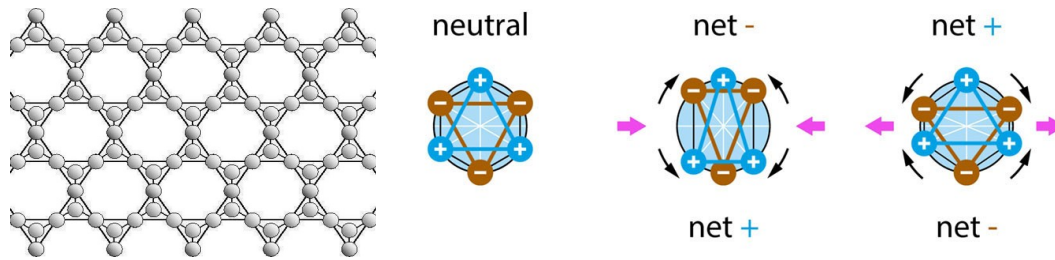

**JH (21/04/2024): Yes!**

How does this open up the singularity?

**JH (21/04/2024): It creates a dynamic reaction between the two polarities and it creates an exponential reaction that triggers the singularity portal. Hard to explain in better words.**

**Proper methods of using the crystal to open the vortex:**

Is it important that the fingers are placed as close as possible to being on either side of the compression node for maximum opening of the vortex?

**JH (21/04/2024): Yes it is.**

If so, then people, for a reference point, can put a small piece of tape to mark the eye as to where to apply a sharp pressure with their fingers in sync with their breath and projected thought as the vortex momentarily opens during the pressure from their fingers.

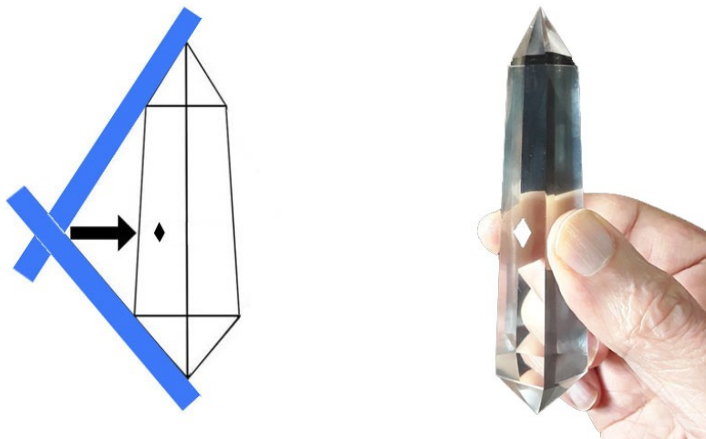

**JH (21/04/2024): Good idea, I see what tape is.**

Assuming it doesn't matter which of the 3 axes that ether finger pressure or silver electrodes are placed on because they are 3 axes are equal in internal piezoelectric geometry correct?

**JH (21/04/2024): Correct.**

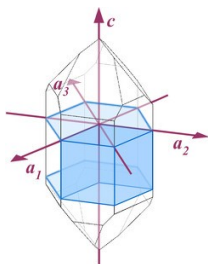

Regarding the size of the crystal. I understand a larger crystal yields more capacity in regards to Phryll generation, but is there much difference as far as the effectiveness of opening or connecting to the vortex eye of the crystal that is related to the size of the crystal? Such as various lengths of 4, 5 or 6 inches, are they all equal in this regard?

**JH (21/04/2024): The size of the crystal doesn't matter, only the pulse must increase in intensity, not rate, as the size of the crystal increases.**

Regarding clearing the crystal. Before opening the vortex momentarily with finger pressure or activating the 20 Hz pulses to the electrodes in order to keep the vortex continually open, is it required to first clear the crystal, such as using the 4096 Hz sound? Or this does not matter in regards to opening the vortex?

**JH (21/04/2024): In order to open the crystal, I believe that it doesn't matter.**

**Application of a frequency key shot at the compression node:**

**Reference statements by Jen Han how to apply a frequency key:**

Jen Han: "You are asking me if you must pulse a constant 1496 Hz, it is not necessary. It is best to pulse for a few seconds and then let the particles adjust their rate, then do it again after a while. Feel the particles telling you when they are craving for more of this frequency. You can also sequence the three frequencies and play this sequence intermittently."

To enhance the opening of the vortex eye with silver electrodes at 20 Hz, I am projecting a 1496 Hz audio signal aimed at the compression node that is not continuous but rather sequenced, similar to the sequencing advised for the Phryll torsion field coils, by using 4 sequence lengths then pausing for 2. For example, I am sending the 1496 Hz sound on for 3 seconds, off for 3 seconds for a sequence of 4 times and then a pause length of 2 sequences or 12 seconds, then repeating this pattern continuously.

Instead of sequencing only 1496 Hz as in that example, would it be any better to sequence the three different frequencies (587, 644 and 1496 Hz) similarly instead? Does this seem like the correct approach to enhance the vortex opening?

How do these sounds that interact with the crystal and act as a “frequency key” function to enhance the opening of the vortex?

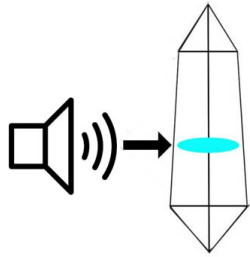

Speaker sound directed at the compression node

**JH (21/04/2024): My dear friend, if it is only a matter of opening a vortex in a crystal, these frequency sequences are correct, but any impulse made on a negentropic frequency, I mean a frequency patterned on love, such as a frequency emitted by consciousness in a state of serene peace, is just as effective, if not more so. Never forget consciousness. Some dissonant patterns of music will simply not open the vortex. Pure - love - intention is the most powerful frequency key to access Source and bridge to the Void.**

#### **20 Hz pulse relationship to opening the vortex:**

Using metallic electronic pulse of 20 Hz to the silver electrodes on either side of the compression node. What determines the quartz having a “harmonic frequency of 20 Hz” to be used for sending pulses to create compression waves into the piezoelectric lattice which allows the vortex to open at this particular frequency?

**JH (21/04/2024): This is how the dynamics works, I cannot explain it in more details. It is linked with the frequency rate of human consciousness which is 21.**

#### **Reference statements by Jen Han regarding the piezoelectric pulse frequency:**

Jen Han: “Remember, sharper is always better. It can be faster than 20 pulses per second of course but 20 is a good vessel for consciousness. Do not forget consciousness.

This is a sharp, pulsated, repetitive pressure. 20 pulse per second with metallic (silver electrodes) technology. Faster will work as well but the harmonic frequency with quartz is 20 pulses per second.

To carry a human thought-form through the crystal's vortex to imprint the hologram, breath pulse works and singular 20 pulse works.

They stimulate the electrons in the atoms in the crystal, until it changes the charge. At each pulse, the charge will inverse. Under a continuous alternate pulse, the crystal will generate Phryll energy.

The Phryll comes from the singularity, that has opened. Crystal you name Quartz is in synchronized frequency with Source. So when you stimulate the singularity, you bridge to Source and you can draw energy from it.

The compression of the node by pulse, generates a piezoelectric effect, which can make the crystal sing as well if you misuse it. The vortex is used to bridge: creative thoughts, densities, and other things.

Do not forget consciousness. 21 also works. Also work for a single monotonic pulse: multiples of 20 such as 40, 80, 160, 320 and so on. Another method is progressively increasing pulses from 20 to 30 to 50 to 80 to 130 to 210 to 340. It is the geometrical measure of vortex's horizon curve. After 340, if you follow this order, the crystal can sing at 550. If you pulse directly at 550, it will not sing. What makes it sing is that you follow the order I gave you, from 10 to 550. but you don't need to do that. To carry a human thought-form through the crystal's vortex to imprint the hologram, breath pulse works and singular 20 pulse works. I sense an experimental mind in Dan.”

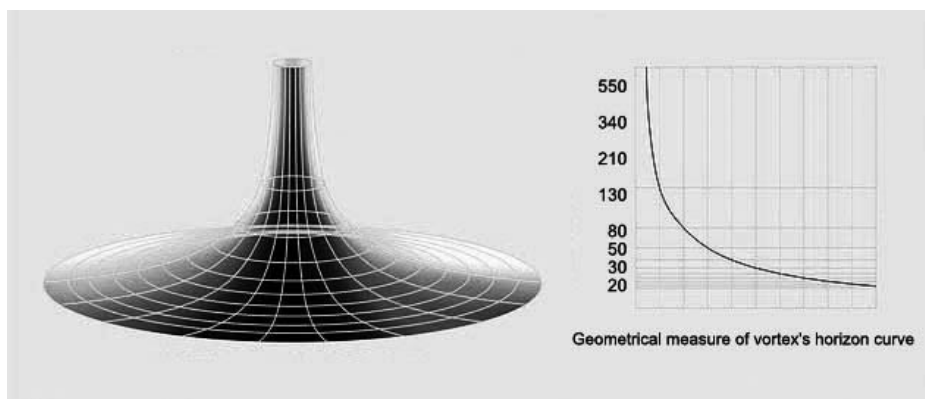

Geometrical measure of vortex's horizon curve

Is this progression of frequencies 10-20-30-50-80-130-210-340-550 Hz plotting the curvature of the vortex form of the singularity wormhole that has been opened?

**JH (21/04/2024): This series opens a singularity.**

If 4096 Hz is the resonant frequency of the quartz lattice, which this frequency is used to resonate and clear the lattice structure of dissonant imprints, then the recommended 20 Hz pulse is representing resonance of exactly what?

And why is 20 Hz a good vessel for consciousness?

**JH (21/04/2024): 20Hz is the overall frequency of Source- Consciousness, with a fractal development for Human Consciousness at its accomplishment: that is 21Hz. There are different rates of Consciousness in the created.**

**4096 Hz resonates with quartz, light, love, and water:**

**Reference:**

Jen Han: “I told you, remember: quartz, light, love, water, have the same frequency.”

If 4096 Hz is the frequency of quartz, does that mean it is the same for light, love, and water?

**JH (21/04/2024): Yes, when these mediums are activated, their frequency increases to that rate. The frequency of light is 430 to 750 trillion Hz in terms of the color spectrum in the universe in which we live. It is a different measure in other universes. 4096 is a fractal core measure of the frequency of light in this universe. The frequency of water is 2.45 billion Hertz. 4096 is again a fractal measure of it.**

If so, does 4096 Hz also clear the patterned imprints in water?

**JH (21/04/2024): Yes, it does. Even when used on your physical body, it shakes the dissonance out of the water that makes up this physical shell.**

In other words can it clear or even structure water to be healthful?

**JH (21/04/2024): Yes it can.**

Can the 4096 Hz be used to clear other quartz based stones that are not clear quartz, such a citrine, amethyst, rose quartz etc. Does it have an effect on other non-quartz based stones?

**JH (21/04/2024): It has an effect on everything. Amethysts are particular, they are extreme receptors and need deeper efforts in clearing.**

According to Oona, the 4096 Hz can resonate and clear the piezoelectric crystals in our pineal gland. Can you speak to why these pineal gland crystals are able to resonate at this frequency?

**JH (21/04/2024): The crystals in your pineal gland are not quartz, but calcium carbonate, which is organically produced by the tissues of the human body. These micro-crystals generate an electromagnetic field at the center of which is an inter-dimensional vortex for consciousness.**

Can you elaborate how 4096 Hz resonates with Love and Light?

**JH (21/04/2024): 4096 is fractal frequency of these two other frequencies.**

On Terra in the past, people used quartz spheres to gaze upon to see other realms. Why is this sphere shape of quartz effective for that? What are these people actually seeing with images in the quartz sphere?

**JH (21/04/2024): Oh, this is an interesting question: When applied to a sphere, the impulse waves of human consciousness create an exponential pressure on the crystal lattice; this mechanism is very powerful because of the geometry of a sphere. The forces applied to the sphere act in a uniform and equal pressure on all points of the sphere, creating a fractal pressure reaction directed to the center of the sphere. Then the vortex opens. I want you to think about this crystal sphere you held, that was found in the remains of the Atlaa civilization. It was found in a room with seats around it. The people focused their consciousness on the central sphere, sending pulsed waves of conscious thought, and the vortex opened. It was a communicator to home. It is now broken. Savage humans. Not ready.**

**ELENA: I may remind here the mechanism of the Vajra, Anunnaki ancient weapon, which I saw in use: a pressure is applied to a crystal sphere, Ea used the expression aswell: “exponential pressure”, and it generates a powerful piezo-electric reaction that ignites plasma in the lateral tubes.**

Is what the Germans once called “Vril” the same as Phryll?

**JH (21/04/2024): Yes it is. The pronunciation is heard the same.**

## CRYSTAL HEALING SECTION:

### Using the vortex eye for healing:

#### Reference:

Elena: Can you remind us how to harvest Phryll with our consciousness?  
I know a method taught to me by Annax but I am interested to know yours.

Jen Han: “First of all, you know about the method that consists in imprinting a younger and healthier template into the holographic pattern of your envelop, using consciousness.”

### Imprinting a younger and healthier template:

What is a good method to imprint a younger and healthier template of yourself using the vortex eye?

**JH (21/04/2024): Visualize the dissonant version using a holographic method (seen from all angles at the same time). Then visualize the resonant version over it. Same holographic way. Let the healthy version descend into the altered version. The resonant version replaces the dissonant version. It is re-pairing. It works by allowing the natural laws of the universe to work themselves out as the universe tends toward perfection.**

### Accessing an earlier healthier point in time in the holographic field:

Using the void to access an earlier point in time for when our body was younger to imprint.  
I understand the med beds can tune through time in the holographic field of time to accomplish the re-pairing of an earlier time when the body was more optimal and healthier.

Our higher density self within us is closer to Source, therefore our higher density self would you say is closer to perfection and that it's energetic body is more optimal in it's formation? Can we bridge that more perfect pattern into our current density using the vortex eye?

**JH (21/04/2024): Do not confuse the understanding of a physical avatar in need of repair with a higher frequency version of your being. Your being inhabits a physical avatar that needs repair, that repair is done with a healthier version imprint of that same avatar.**

When a being such as Prince Ea, has reached a state of immortality, does this state require a high level of his being to be primarily a direct expression from Source which allows him through alignment with Source to regenerate himself, because Source is eternal?

**JH (21/04/2024): I do not know Prince Ea and I am not familiar with him, you better ask Elena. But I would guess that I think you just described physical immortality in your own words.**

**ELENA: Ea has reached immortality by a journey of his consciousness through all the states of existence on the ladder of frequencies leading to Source. Once he arrived there, he had power over matter, and over his own body. But that included as well a chemical transmutation of his physical body. A very complex procedure. I know he suffered and exulted; it was a journey that was challenging to the core of his being. Ea can fractal life directly from Source.**

### **Vogel/Eredyon cut crystal healing:**

When using a Vogel/Eredyon cut crystal for healing, and there is a distortion (an ill or sickness) in a person's envelop, what would be a good method to restore a healthy pattern in the body to allow it to heal using a Vogel/Eredyon cut crystal?

**JH (21/04/2024): The method described in our earlier correspondence that your friend Marcel came up with is very good, but little did he know that his own consciousness was bridging the frequency of the altered bodies to Source. Visualize the re-paired perfect pattern over the damaged one until you force the vision until the damaged version no longer exists in your mind's eye.**

### **Healing others at a distance:**

When you wish to help another being with their permission using the vortex eye of the crystal, how best to proceed?

**JH (21/04/2024): Permission is always required, otherwise you are violating Universal Law. Interference without permission is punishable by universal law. Sooner or later, the Source will correct the mistake in its own way. To heal at a distance, use visualization as I described earlier here. The crystal stands between you and the damaged body. It will project the pattern onto the damaged body. I see you want a point-by-point procedure. This is my suggestion:**

**-Clear the crystal.**

**-Stand relax with no muscular tensions and so does the patient in front of you. Facing each other in parallel fields. Calm of mind and of heart. Ask the patient to breathe slow and deep and generate enjoyable thoughts in order to elevate their consciousness frequency. It takes the time it takes to set these conditions up.**

**-Open the vortex of the crystal first.**

**-Open your own pineal vortex.**

**-Visualize the wounded area. Bring it from your physical eyes to your pineal eye.**

**-Create the re-paired holographic version within your mind.**

**In your pineal eye. Because it is open, you are imprinting this in source.**

**-Imprint the repaired version into the damaged version, in your mind's eye.**

**-Project this re-paired version into the crystal's eye.**

**-Point the 60 degree angle to the wounded physical area of the body of the patient with winding movement clockwise. Until you feel it is casted into the morphogenetic field of the person.**

**Breathe into the crystal and the same time, regularly, the repaired hologram from your mind's eye. The crystal is the bridge.**

**I would proceed like that. We have technology that does that here, but this option is great as it trains you in the use of your consciousness.**

### **Traditional Vogel multi-sided cut crystal healing:**

For the many Terrans who own a multi-sided Vogel cut crystal (as opposed to a Vogel/Eredyon cut) do you have any recommended Pleiadian techniques for healing with those type crystals?

**JH (21/04/2024): the method is the same, just not as efficient in results. Keep in mind that what I am giving you as a method is not absolute; there are other variants to use crystals for physical healing.**

### **Jen Han's perspective of Dr Marcel Vogel's healing techniques:**

On Terra, Dr Marcel Vogel developed crystal healing techniques that he taught doctors and the public using specially cut di-pyramidal cut crystals with varying number of sides which he believed help to cohere and thus amplify the energies of mind. He had a good degree of success with his techniques, of which I would like to sort out from your perspective, which elements of these techniques you feel could be useful in the healing process using a Vogel type crystal. In other words, what is based on "belief" and what is based on "science".

**JH (21/04/2024): Regarding the list below, I will reply with B for belief and S for science.**

### **Dr Marcel Vogel's procedure ultra simplified:**

**S** With the person's consent, the crystal is brought into the area of the thymus on the body.

**JH (JH (21/04/2024): the Thymus is the entry point to the Body's morphogenetic field.**

**B** With the other hand sensing at the back of the body

**JH (21/04/2024): This is not necessary, it is only for the therapist to sense and contain the etheric field of the body, at the place where an influx of Phryll is given. It provides balance.**

**S** The crystal is rotated clockwise until a resonance is felt

**S** The person would ask to be shown in their mind the source of the dissonance or pain

**JH (21/04/2024): good point. The person will be part of the healing procedure on their own body.**

**S** Unifying with the person with synchronized breathing and with the person locking onto that source

**JH (21/04/2024): bonding consciousnesses, bridging to each other to work in harmonic resonance.**

**S** A synchronized release pulsed breath expels the dissonant pattern from the body

**S** Love is then directed to integrate that area of the body whole again.

**Question of the angular rotation of a crystal to resonate with an etheric body:**

Dr Marcel Vogel called this the “critical rotational angle”. He believed that when the crystal is within the etheric field of a person, that when the crystal is slowly rotated, that at one point there will be felt a resonance with the etheric field. This was for coupling into the etheric field of the person.

My question is, is there an angular resonance of the crystal’s lattice structure with a person’s etheric field?

**JH (21/04/2024): No, as the etheric field is a torsion field in constant movement.**

On Terra, there have been instruments constructed that are used as you could say a tuning focus for the mind, that use rotational dials to resonate with the etheric field of anything. The concept is that everything in the universe can be attuned to with a specific angle within a full 360 degree circle. In order to fine tune this great spectrum, multiple dials are used.

This angular resonance appears to hold a key in understanding this matrix. Such as the molecular angles of quartz at 52 degrees appear to be harmonically related to that of water which is 26 and 104.5 degrees and through this angular harmonic resonance, information can be transferred between them?

**JH (21/04/2024): I do not know what technology you are referring to. You do not need angles to align with the Universe when you consider that the center of the Universe is within each nucleus of your own cells and the photonic particles of your own being. There is no angle, no circle, no point, no linearity. Source consciousness is Unified.**

## Healing of Others Condensed Dr Marcel Vogel Procedure:

### 1) CLEAR CRYSTAL

Methods Marcel used were either pulsed breath with intention or magnetic bulk eraser

### 2) CHARGE AND LINK TO CRYSTAL

Pulse breath with love and rotate in hand and squeeze to charge crystal to be an extension of self

### 3) TUNE INTO ETHERIC BODY

Crystal 1-2" from thymus area with left hand at the back of the person as a sensor

Hold breath and rotate clockwise to resonance with etheric body. When resonant release breath



Rotate Crystal Clockwise to Etheric Field Resonance - Marcel called this the "critical rotational angle"

Thymus Gland is the "witness area" for the entire body

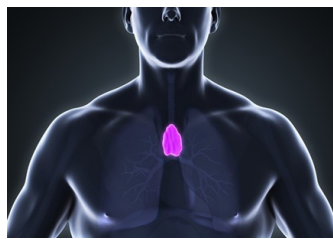

### 4) BREATH IN SYNC TO UNIFY

Synchronized breathing together to build energy and unify with person

### 5) AMPLIFY FIELD

Amplify with up/down motion with breathing



### 6) PERSON IDENTIFIES DISTRESS SOURCE

Person goes with mind to source of distress and describes.

### 7) LINK WITH DISTRESS SOURCE - PERSON UNIFIES WITH IT

Start clockwise circles over thymus to link with the source of distress.

Person to be at one with the source of distress



### 8) AMPLIFY LINK TO DISTRESS SOURCE

Link with area of source of distress increasing in speed with crystal spinning vortex over thymus area

### 9) PERSON LOCKS ON AND RELEASES ON COMMAND!

Build up breathing in sync and at inhalation peak have person focus on the source of distress, lock their mind on it and then command to RELEASE! Both pulse breath out in sync to release.

Break the dissonant pattern apart and the connection with it.

### 10) STABILIZE AND REINTEGRATE

Seal the etheric incision operation with love using an up and down motion, then link all chakras into a large ovoid motion. To stabilize return hands to holding crystal over thymus with other hand on back.

If appropriate give a big loving hug at end of session.

## **Dr Marcel Vogel's healing self with crystal procedures:**

### **To balance the body:**

- 1) Clear the crystal of previous imprints
- 2) Hold both crystal ends with the left and right hands
- 3) Focus on a facet and pulse your breath then rotate to next facet (3 times for 6 sided crystal)
- 4) Reverse the crystal ends with the left and right hands and repeat the same

### **Going through the crystal to bring in bright light to the area to be healed:**

- 1) Clear the crystal of previous imprints
- 2) Charge and link into the crystal by pulsing the breath
- 3) Take a deep breath and hold, close eyes and see tip of crystal and let your breath out
- 4) Holding the image of the crystal, breath in and go from the crystal to the area to be treated
- 5) Breath in and bring in clear bright light and release it with breath through the crystal to that area

### **Rotate crystal into your etheric field and then visualize area to be healed:**

- 1) Clear the crystal of previous imprints
- 2) Rotate crystal to resonance of etheric body using left hand to sense
- 3) Confirm resonant connection through movement
- 4) Close eyes and go into the crystal with pulsed breath
- 5) Go into area to be treated and visualize what needs to be done
- 6) Go with circular motion
- 7) Draw breath in increase speed and release

**JH (21/04/2024): These methods I have just read are effective. I wish I had known such a great mind and such a vibrant being as Marcel Vogel. His legacy must perdure and be used to assist the people of Terra in their evolution of consciousness.**

**Your work is admirable. Your devoted friend, from Mars.**

## Jen Han Eredyon Session – 04-30-2024

Dear Elena, just two questions. One from Chris regarding laser interferometry measurement, and one of the old questions from last year that got missed regarding sequence timing of the torsion field power.

### Reference:

[Chris asks 04-04-2024]

**Can the phryll be detected by an infrared camera ? If yes, what is the best wave length range ?**

**JH April 10 2024: Good day Chris. I believe you were working on proving our assistance in disabling a rocket that was going to put harmful satellites into orbit. Well, infrared doesn't capture the Phryll well. Have you tried a coherent light wave like a laser? Phryll radiation interferes with lasers. In truth, coherent light and Phryll have a good interaction. Never forget consciousness, consciousness can bend Phryll.**

[Chris asks 04-12-2024]

Hello, dear Jen Han, I am so honored to be part of this team, and to have this opportunity to exchange with you. Yes, I am the guy who decoded the message "777" from the Federation, and now, organizing a big event in France next July, with Elena, and where Dan will present remotely the Phryll generator. Michael Salla (may be you know him) will be there too.

A question about the detection by laser interferometry : is one of these two principles as shown in these images suitable for phryll detection with laser interferometry?

Which configuration is better : horizontal or vertical configuration ?

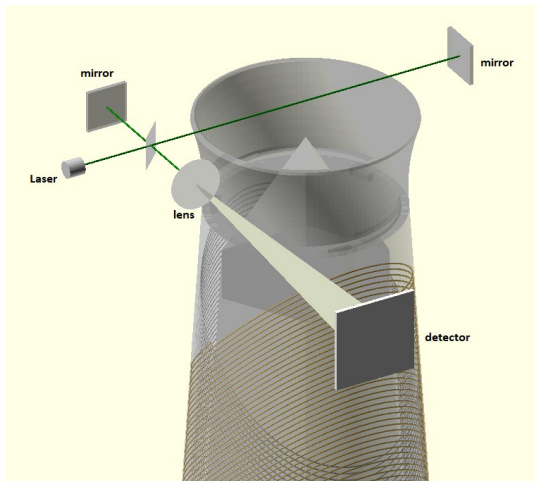

horizontal

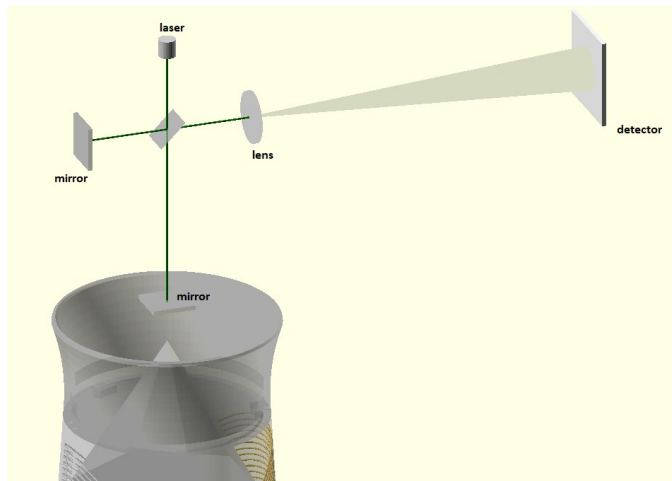

vertical

**JH April 30<sup>th</sup> 2024:** You will get few results with the vertical sensor array. The horizontal array will better capture the movement of the Phryll stream. You see, the Phryll emission is like the movement of a fountain of energy, taking on the dynamics of the torsion field. If you catch it when it just comes out, at the top, in what you call a pyramidion and I call a harvester, you get most of it. But the flow is going to be straight and constant. What you want is to measure fluctuations in the flow, and the horizontal array is the best way to do that.

**Dan 04-12-2024**

This below question on sequencing the power was the last of the old unanswered questions that got missed. Now that we will be increasing the power to the torsion field coils, this may greatly increase the chance of the crystal singing from our previous “feeble” level of Phryll output, so this may be useful information.

**Reference:**

**JH: I do not have the technical numbers in Terran time scale here but I will ask in the lab. Usually, time is a quarter of the impulse but I am not sure.**

*(back after a few minutes)*

**46 Terran milliseconds as a unit, that you can put in sequence for larger range. That is what they say. They are not aware of my participation in this project so it was amusing avoiding their questions.**

**Dan 11-14-2023:**

**Regarding sequencing the power:**

**If 46 ms (milliseconds) is considered a unit of sequence if I am understanding correctly?**

**Then with the frequency of 4096 Hz, each pulse would have a period measurement of 0.244140625 milliseconds, which would allow 188.4 pulses to occur within a 46 milliseconds duration of being turned on for that unit of sequence. Is that correct?**

**JH April 30<sup>th</sup> 2024: It is correct.**

**If this is so, then for sequencing using this unit of sequence measurement would be...**

**4096 Hz sequenced 46 ms ON and then 46 ms OFF for 4 times – total time 92 ms x4 = 368 ms  
Then pause for ½ of that time of 368 ms /2 = 184 ms before repeating the next 4 sequences**

**Here is a visual example of the spacing between the 4 bursts of pulses if they are equal to the 46 ms length of the burst? Would the spacing between bursts be equal to the length of the burst?**



**JH April 30<sup>th</sup> 2024:** You can make the spacing shorter by half. Between the pulse sequences and in the interval between them. Understand that I cannot deliver this technology to you; it needs to come out of your brilliant minds; I am only here to assist, considering the Prime Directive.

## **Jen Han Eredyon Session – 30/05/2024** (Note change in date format to Day/Mo/Year)

Dear Jen Han, you are always so gracious to answer my multitude of questions. Your answers always expand our understanding of which I am so grateful for. Your last exchange was a great birthday present to receive from Elena, as it was rich with knowledge and wisdom. The following questions are for clarification to help further our understanding.

### **Referencing Jen Han's statements:**

JH (21/04/2024): This is correct; the 51,843 angle geometry transponds etheric energy and the 60 angle geometry imprints it into the holographic matrix of the universe. This is a great network. This is how we implement etheric energy into physical reality, and this is how the Liminal Geometric Point of Transfluxation allows the intentions of consciousness to imprint a geometric thought pattern.

So do I understand correctly, that the all pervading ether is transponded by the 51.843 degree pyramidion end of the crystal into a double coiled torsion field vortex of Phryll from the ether, whose geometry is related to Phi or pentagonal geometry that conjugates together with the different ratio of an opposite counter rotating dynamic of the double coiled torsion field vortex of the 60 degree pyramidion, whose geometry is related to tetrahedral or hexagonal geometry. It is the ratio of this vortex frequency phase difference between these two vortex geometries that conjugate to form a node which opens a singularity in the vortex when the crystal lattice structure is piezoelectrically stimulated. It is within this phase conjugation node that is the liminal geometric point of transfluxation, where the geometric patterns of information originating from the inter-dimensional vortex of the pineal gland the energies of a conscious mind that can be imprinted into the lattice structure of the void which has been opened up by the singularity within the open vortex of the crystal.

**JH 30/05/2024: This is exact. The transfluxation allowed by the stimulation of the double flux coils, opens a singularity through which the ether is transponded into energy. The piezoelectric stimulation is of major importance. Longitudinal waves are universal stimulators for the activation of Phryll and many other technologies. In the pineal gland of the human body, thought is the piezo-electrical longitudinal impulse that stimulates the micro crystals contained in this gland, and the same process occurs. A vortex opens. Here, no inverted coils as you find it in a Vogel cut crystal, but the natural rising double helix of the human power coil, that opens the singularity.**

The intention of this imprinted pattern is then sent to the 60 degree pyramidion end to write the imprinted pattern into the tetrahedral geometry lattice structure of the fractal holographic matrix in all densities that is imprinted into the lattice structure of the void, where the element of time in the void does not exist, so the imprinted information perpetuates indefinitely in order to bring it into physical reality the manifestation of that intention into the lower densities of physical reality?

**JH 30/05/2024: this is correct**

So is using crystals in this manner with your consciousness what you refer to when you said that "This science is used to create worlds" ?

**JH 30/05/2024: This science is used to shape the Universal Holographic Grid as we wish and embed complex mathematical geometry frequency keys into it to create the blueprints we need.**

**The parts of the matrix where these blueprints are embedded will organically evolve according to these patterns.**

Can this be looked at like a “reality modulator”, as the process of the ether flowing into the receiving or transponder end of the crystal and then flowing out at the emitter end, with the vortex eye of the crystal in-between this inflow and outflow when opened piezoelectrically, that consciousness can modulate (encode information) into the fabric of reality to come into form?

**JH 30/05/2024: reality modulator is a good term. Reality shaping technology is also an appropriate term.**

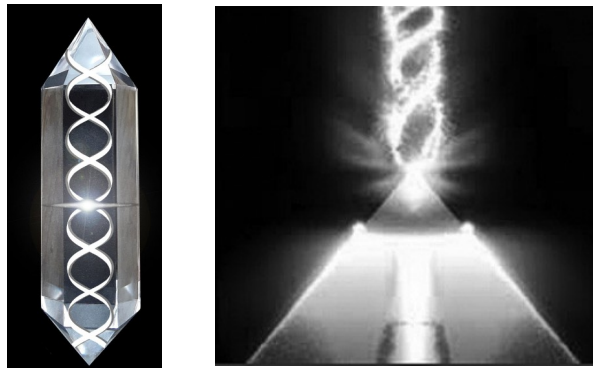

\_\_\_\_\_ The double coiled vortex formed by the pyramidions

**JH (21/04/2024): This is why you and your beloved companion are at the maximum health potential of your physical body avatars. Recently you both should have died of poisoning but the geomorphic structure of your habitat saved your avatars by energizing your DNA bonds.**

You were made aware that we were not just sick but rather intentionally poisoned?

**JH 30/05/2024: Thor Han told me.**

This poisoning, I am assuming you are referring to the Mount Shasta conference in July, 2022?

**JH 30/05/2024: I do not remember the exact location but if that is when you were poisoned of course we are talking about the same event in time and location. The date is right.**

Do you know if the poisoning was done by deep state assets that wanted to silence us?

**JH 30/05/2024: Yes, with no doubt. My brother has more information but, in my opinion, this was an obvious attempt of murder. They surely foresaw your future positive impact in the future of Terra. You see, these dark agents infiltrate all your conferences and work for darker organizations, with the shady layer of your governments. You must be careful. Your wife is worried about this I can feel her frequency through you when I am scanning you.**

I'm glad to hear that the dome geometry supported our DNA to sustain that assault!

**JH 30/05/2024: I am glad too. But also, besides your habitat's geometry, your impeccable diet both kept your biological functions at the top of fighting capacity, and played a crucial assistance in restoring your health. You were also helped remotely in your healing process. Thor Han knows all of these details. I am not very knowledgeable in Terra's intricate politics. But glad you went through!**

---

**JH (21/04/2024): The void allows for imprinting into the grid of the universe from which you are working. It bridges it by accessing the keys of the morphogenetic grid. But it is within the grid of the universe from which you are working that this intention is actually imprinted.**

So do I understand correctly that within the void there is this grid lattice structure of the universe? So the void is not completely devoid of everything, there is this grid structure within it?

**JH 30/05/2024: No, the Void is void. There is no lattice. It bridges universes together acting like a medium through which the information can leap from one universe to another.**

This grid lattice structure, I am assuming is the same as the multi-dimensional geometries of the flower of life pattern whose nodal points in the matrix forms some of the fundamental geometrical angles?

**JH 30/05/2024: Correct my friend.**

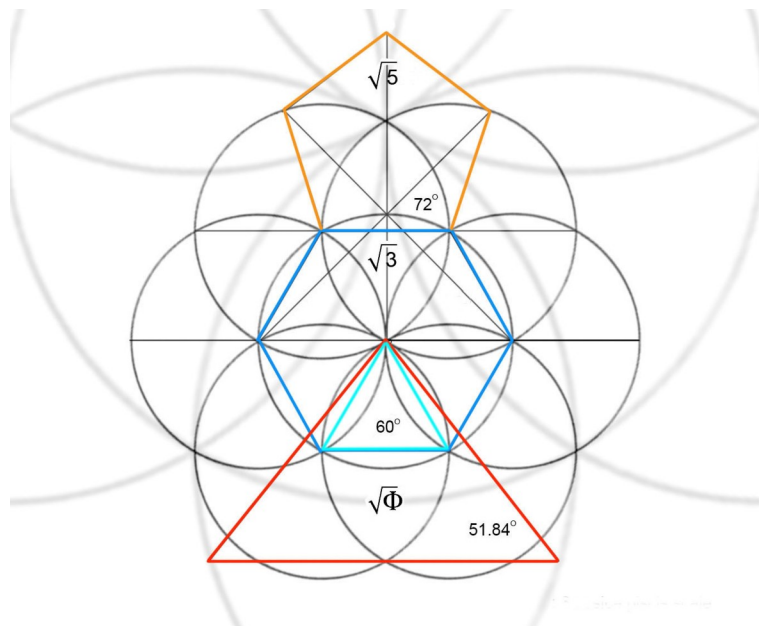

It is this “lattice grid structure of the void” the structure of the void as you referred to earlier as being “in an ordered state of geometrical resonance” that will not allow dissonance to effectively imprint into the void? So that using the void to imprint a dissonant thought pattern will not take effect or a very feeble effect at best? If so, then this is a good thing that imprinting into the void can not be abused.

**JH 30/05/2024: There is a greater lattice structure which is the structure of Creation. The Void is part of it as void. Then, consider that each universe has a specific holographic lattice structure which outer limits are the limits of the bubble in which that universe is contained. In-between the bubbles, there is no lattice structure but the greater lattice that holds all the universes together as the multidimensional pattern you name the Flower of Life. The Void cannot be abused, but when you access the Void, you can access all the universes. It depends then of your intent. You cannot imprint anything into the Void as it has no lattice, but any action that is brought into the Void affects all the universes. That is the reason why the Nebu wanted to access the Void.**

---

**JH (21/04/2024): My answer is above: It is written in the grid structure of your universe, which is where you live and where the intention was created. You can only bridge your intention to other universes or dimensions by accessing the Void, but it will not be effective unless you have an anchor point.**

**JH 30/05/2024: Do you understand now what I was saying? I am glad you asked me for clarification.**

Assuming the terms “universe” and “dimension” are interchangeable and meaning the same thing?

**JH 30/05/2024: Yes.**

Normally it would seem, you would only wish to imprint into the void to affect the universe you are in and not a different universe, and so you would normally not need an “quantum anchor point” correct?

**JH 30/05/2024: The Void is the bridge. The original neutral medium where the seeds of Creation are planted. Correct regarding your last question: if you only want to reshape the grid of your universe, you do not need an anchor point to another universe.**

What would you define as an “quantum anchor point” if you ever needed one?

**JH 30/05/2024: A Resonance or entanglement point. They are difficult to create and we are here in a more complex, interdimensional science.**

---

**JH (21/04/2024): That is correct, and how Imana, Source as we call it in my culture, can be depicted as a central sun shining rays of created energy down into its lower realms of creation. Again, nothing is linear in the absolute reality of Source. Frequency rate is linear because it is scalar, but densities are superimposed.**

The structure of the densities being superimposed upon each other as related to frequency of consciousness and conscious perception. I understand that those within the lower densities can not perceive those of the higher densities. But that the higher densities can perceive those in the lower densities. Is that true?

**JH 30/05/2024: It is true. Depending on your species and degree of perception related to your biology and also your evolution in consciousness.**

I heard once from Elena that the GFW military when battling the Ciakahrrs can be invisible to them and then they can shift into their lower density to surprise attack them. Can you elaborate on the difference of conscious perception operating from different densities?

**JH 30/05/2024: It is due to a variance in the frequency rate of the lattice of physicality. When you vibrate faster you become invisible to slower densities. This rate of vibration goes by pair with the rate of vibration of consciousness. The example is simple: vibrate hate and you will remain at a lower and slower rate of density. Vibrate love, and you can shift higher more easily. It is all a question of frequency.**

When you said the densities are superimposed upon each other, does this relate to the geometrical nesting of the spectrum of frequency harmonics of the various densities?

**JH 30/05/2024: Yes. There is a basic lattice proper to each universe, upon which the fractals of resonance can be scaled like harmonic octaves.**

If the higher densities affect the lower and not visa versa, then are the conscious beings operating at a higher density continually affecting the reality of beings in the lower densities?

**JH 30/05/2024: Yes.**

When Elena wears a “density belt” in order to adapt to a different density, what is essentially happening to allow her to be in this different density?

**JH 30/05/2024: this belt transponds, same as a crystal, the speed of vibration of the particles of her body to a faster rate, adjustable to where she is taken.**

---

**JH (21/04/2024): It creates a dynamic reaction between the two polarities and it creates an exponential reaction that triggers the singularity portal. Hard to explain in better words.**

This exponential reaction from the piezoelectric activation by the off setting the quartz lattice structure triad balance. Is this because of the fractal geometrical nature of the quartz lattice structure exists not only in the density that is stimulating the structure, but due to the infinitely fractal network of charge triads being offset in multiple densities at the same time is the cause for this exponential reaction?

**JH 30/05/2024: That is an interesting view. Yes, quartz is a density transponder and any charge or pressure applied to it impacts multiple densities. Usually one above and one below. When I mentioned “exponential reaction”, I intended to say: an exponential multiplication of charge, such as, as you know, in what you call a black hole. The exponentiality of charge is happening at the eye of the crystal and that is how it opens a vortex.**

---

**JH (21/04/2024): This is how the dynamics works, I cannot explain it in more details. It is linked with the frequency rate of human consciousness which is 21.**

To open the vortex with metallic silver electrodes you said that ether 20 or 21 Hz will work. That 21 Hz is a frequency rate of human consciousness. Is one frequency more effective than the other for the vortex opening? This oscillation of 21 Hz, is this a set rate that is associated with Terran brains? Would this frequency be different with an Ahel brain such as yours?

**JH 30/05/2024: Yes, consciousness has different frequency keys regarding their origin and nature. They are much complex multidimensional formulas.**

It’s interesting that Dr Marcel Vogel believed there was an oscillation within our skull cavity, and I am wondering if this frequency is related?

**JH 30/05/2024: Oh, this is surely it.**

---

Dan: Is this progression of frequencies 10-20-30-50-80-130-210-340-550 Hz plotting the curvature of the vortex form of the singularity wormhole that has been opened?

**JH 30/05/2024: This is the ratio formula of the curvature of a wormhole.**

**JH (21/04/2024): This series opens a singularity.**

How is this singularity opening any different from only pulsing at 20 Hz?

**JH 30/05/2024: with this series of valuable numbers, the vortex opens deeper, farther and is more durable because the numbers keep it stable.**

This progression of frequencies that represent the geometrical measure of vortex's horizon curve, can you explain what vortex this is referring to, is it the worm hole vortex in the eye of the crystal?

**JH 30/05/2024: These are universal formulas. You see the numbers but you need to visualize also the geometry keys that are a crucial component of it. This ratio is worth for any vortex, from infinitesimal small to the greater size of a black hole.**

I tested pulsing at 20 volts this sequence of 10-20-30-50-80-130-210-340-550 Hz entering each these frequencies manually with no delay between them. First with a duration of about 5 seconds then 10 seconds on each of the 9 frequencies in succession, but was unable to detect with a sensitive audio meter the crystal producing the “singing” audio indicating saturation. Am I doing something incorrectly?

**JH 30/05/2024: In the Earth’s electro magnetic field the measurements are different. It is different on every planet. Try pulse a higher voltage, such as twice the impulse.**

---

**Question to Elena and to Jen Han:**

Elena you mentioned on a recent interview that if you use this progression to make the crystal sing, that you could stop the frequency excitation and hold the crystal that is singing in your hand and that a high level of Phryll charge could be discharged beneficially into your body. Is this correct?

Ref [https://www.youtube.com/live/jd3wNIp\\_z80?si=gU2WiiVnNm\\_L4-iu&t=3307](https://www.youtube.com/live/jd3wNIp_z80?si=gU2WiiVnNm_L4-iu&t=3307)

Transcript:

Tim/UFOman asks: “I read on your page (*I couldn’t find this on your website*) that when it sings you can hold the crystal in your hand and it will possibly help with healing, is this the case?”

Elena: “Yes, when the crystal sings it's overloaded so the frequency emits a frequency that becomes audible and that's not good, because if it starts to levitate it can explode, but as long as it's not levitating, if you can you take it in your hand, you can absorb the energy and it's fantastic and incredible energy that comes from it. You know when it's saturated and it just gives out but it has so much in store that in storage that it barely can manage to eject it. So if you help the crystal you take this energy this Phryll this is an amazing effect on your health and it's quite remarkable.”

If this is so, then a device could be engineered to couple to the crystal momentarily to run through the frequency progression up til it sings and then disconnect allowing you to hold the Phryll energized crystal in your hand. We can create this, is this something worth pursuing?

**ELENA: I forgot I said that, I must have remembered it from my Altean knowledge. Interesting how information downloads out of our deep memories at the right moment. It is like if we are connecting to a higher vibrational part of our being and access these memories.**

**JH 30/05/2024: I was taught to be careful with the singing crystals, but sure the Alteans can vacuum the overload of energy and store it in their technology. I believe the human body is the best technology, as it is directly connected to Source Creator.**

---

**JH (21/04/2024): 20Hz is the overall frequency of Source- Consciousness, with a fractal development for Human Consciousness at its accomplishment: that is 21Hz. There are different rates of Consciousness in the created.**

Could you expand on this? Are you saying that the next level of fractal development of our consciousness is going from 20 to 21 Hz?

So the overall frequency of Source is 20 Hz, so is this 20 Hz universal for all beings in this universe that are at different rates of consciousness?

**JH 30/05/2024: This is the Source impulse, but frequency remultiplies fractally and increases as life reaches higher states of development. 20 Hertz is the pulse of creation, that splits parts of Source creator into individual consciousnesses. There is a mechanism that unfolds after, from it.**

---

**JH (21/04/2024): Yes, when these mediums are activated, their frequency increases to that rate. The frequency of light is 430 to 750 trillion Hz in terms of the color spectrum in the universe in which we live. It is a different measure in other universes. 4096 is a fractal core measure of the frequency of light in this universe. The frequency of water is 2.45 billion Hertz. 4096 is again a fractal measure of it.**

So the 4096 Hz frequency is fundamental to everything in our universe as it is a fractal or harmonic integral of it.

The square root of 4096 is 64, is this related to the 64 tetrahedron grid?

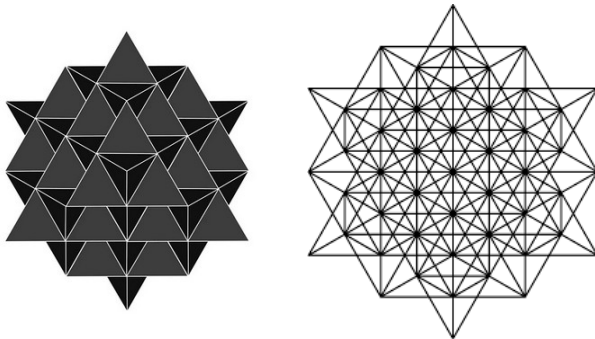

According to scientist Nassim Hamein:

“The 64 tetrahedron grid is the first harmonic of the cuboctahedron geometry and what eventually becomes, with scalar octave growth, the infinite holofractographic vacuum structure of the entire universe”

Does this sound correct?

**JH 30/05/2024: Oh, Dan, you get it right. Here is the scale of creation. Carbon is one of the building blocks of organic life, as is silicon and sulfuric acid, for example. All fractals of the Source**

**Light frequency are elements that go into the creation of any life form that can support the growth of consciousness.**

Regarding the frequency of water, it is concerning that on our planet that if the frequency of water is 2.45 GHz (billion Hertz) that our electromagnetic environment is saturated in this frequency band in which the center frequency is exactly 2.45 GHz (2.4 to 2.4835 GHz) with WiFi, Bluetooth and countless other wireless device signals that operate there. I wonder if using this heavily populated part of our frequency spectrum is affecting the waters of our planet and our bodies?

**JH 30/05/2024: It unfortunately does. That is why it is clever and healthy to consume water that has not been charged with entropic frequencies. You can also heal water with frequencies. Same as you can clear a quartz and your frontal vortex gland.**

---

If so, does 4096 Hz also clear the patterned imprints in water?

**JH (21/04/2024): Yes, it does. Even when used on your physical body, it shakes the dissonance out of the water that makes up this physical shell.**

In other words can it clear or even structure water to be healthful?

**JH (21/04/2024): Yes it can.**

Our science team will no doubt be experimenting with this application of the 4096 Hz to beneficially affect water, thank you for this potential new application!

For clearing water do you recommend sound waves or electromagnetic waves at exactly 4096 Hz?

**JH 30/05/2024: sound waves.**

With quartz, the 4096 Hz vibrates dissonant patterns out of the lattice structure. With water, are the pollutants oscillated out of the water or are they neutralized out of existence? How does this cleaning of the water occur?

**JH 30/05/2024: This is the work with frequency technologies: there is no "pollution" in re-tuning or repairing. Frequency healing changes the rate of vibration of the particles in a body, be it water, organic tissues or crystals. There is no "dumping" of altered matter or energy, for it is not a process of cleansing but of re-tuning. It is like working on a musical instrument. The dissonant patterns that vibrate outside the lattice structure of a chosen body are different: they are intrusions due to radiation contamination or programming. These dissolve outside the lattice structure as they re-tune to the harmonic universal frequencies. A programming cannot run errands outside of an entangled vessel. When a programming is disembodied, it "evaporates". The harmful radiation emitted by these devices on the planet Terra is only harmful when it passes through a physical body that contains either water or micro-crystals. Unfortunately, the human body contains both, so they are very harmful to humans. The use of sonic clearing technology solves the problem. 4096 Hz can achieve this result.**

According to Oona, the 4096 Hz can resonate and clear the piezoelectric crystals in our pineal gland. Can you speak to why these pineal gland crystals that are not quartz are able to resonate at this frequency?

**JH (21/04/2024): The crystals in your pineal gland are not quartz, but calcium carbonate, which is organically produced by the tissues of the human body. These micro-crystals generate an electromagnetic field at the center of which is an inter-dimensional vortex for consciousness.**

**JH 30/05/2024: because carbon is a fractal of the creation frequency, as I explained. It also resonates to 4096 Hz.**

So is this inter-dimensional vortex created inside the pineal gland due to the geometry of the pine cone shape that interfaces our consciousness to our physical envelop?

**JH 30/05/2024: This is where your soul is entangled to your body. This specific place in the human brain is the quantum conduit to the origin singularity point of Creation. The geometrical shape of the pineal gland is not what generates the vortex but it has shaped and built upon the shape of the vortex' field. The crystals that this gland contains are interdimensional transponders.**

This pine cone shape may possibly be acting like a log periodic antenna, which is a type of antenna designed that is equally resonate across a wide spectrum of frequencies?

**JH 30/05/2024: yes this shape allows the transmission of signals and enable direct communication to entangles points in the universe. It can be anything, anyone or any destination.**

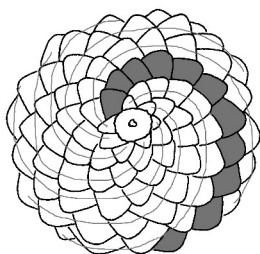
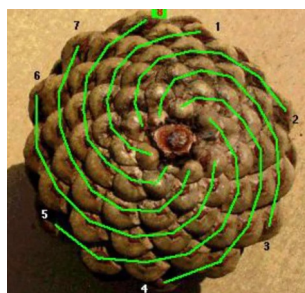

**JH (21/04/2024): Oh, this is an interesting question: When applied to a sphere, the impulse waves of human consciousness create an exponential pressure on the crystal lattice; this mechanism is very powerful because of the geometry of a sphere. The forces applied to the sphere act in a uniform and equal pressure on all points of the sphere, creating a fractal pressure reaction directed to the center of the sphere. Then the vortex opens. I want you to think about this crystal sphere you held, that was found in the remains of the Atlaa civilization. It was found in a room with seats around it. The people focused their consciousness on the central sphere, sending pulsed**

**waves of conscious thought, and the vortex opened. It was a communicator to home. It is now broken. Savage humans. Not ready.**

I did not physically hold the crystal from Atlaa, but I took a special crystal holding it closely above it and with intention transferred the energy from it into the crystal. I still have that crystal sitting on my desk and have never cleared it. Yes, savage humans, I believe there was a nefarious deception done to swap it out for a false broken crystal as a cover story for those who wished to acquire it.

Interesting that the purpose was for communications. Dr Ray Brown who found the crystal, said it looked like tremendous energy caused burning on the hands holding it from intense heat radiating from the crystal sphere. This small quartz sphere would have been difficult today on Terra to reproduce, as within it's quartz structure it had within it multiple triangular shape grids. Any idea how these triangular thin wire grids served in it's functionality?



**JH 30/05/2024: Understand the structure of this sphere as the equivalent of one of your computer's micro-processor chips. This is Altean technology. It goes beyond our understanding and they are secretive about this.**

---

What is a good method to imprint a younger and healthier template of yourself using the vortex eye?

**JH (21/04/2024): Visualize the dissonant version using a holographic method (seen from all angles at the same time). Then visualize the resonant version over it. Same holographic way. Let the healthy version descend into the altered version. The resonant version replaces the dissonant version. It is re-pairing. It works by allowing the natural laws of the universe to work themselves out as the universe tends toward perfection.**

Visualizing your full holographic dissonant current version of your envelop from all angles at the same time is quite a mental visualization task. I assume once you accomplish that and then can visualize the resonant, non-dissonant, healthier more optimal pattern to be overlaid and re-paired onto the old pattern, at that point you would pulse your breath that completed visualization into vortex eye correct?

**JH 30/05/2024: That is a perfect method, that works well.**

To assist in the mental imagery, which takes a lot of imagination, I wonder if using a younger photograph image of yourself for reference would aid in this process?

**JH 30/05/2024: Yes, anything that can help your mind focus on the goal hologram.**

It's good to know that you always have the universe working with you to support you moving towards greater perfection!

**JH 30/05/2024: Always, my friend, always. Even when you do not know about it or worse, have disbelief.**

---

**JH (21/04/2024): Do not confuse the understanding of a physical avatar in need of repair with a higher frequency version of your being. Your being inhabits a physical avatar that needs repair, that repair is done with a healthier version imprint of that same avatar.**

This differentiation is important to know that we are inhabiting a Terran envelop connected with a bloodline genetics etc. which is different from our soul being or Isbe that is interfacing with our avatar probably through the pineal gland inter-dimensional vortex as you mentioned earlier.

Is obtaining an optimal physical envelop form, similar to how the technology of the med beds are limited to only be able to return the physical body to an optimal state that had already once existed at a previous point in time by tuning through the holographic field of time to record and playback an earlier healthier body pattern that existed somewhere between the beginning of our avatar's conception and our current body state, to a time when all components of the body were optimal previously, or is it possible to exceed this previous optimal state of our body of this current lifetime?

**JH 30/05/2024: I do not understand your question my friend please reformulate.**

---

**JH (21/04/2024): The method described in our earlier correspondence that your friend Marcel came up with is very good, but little did he know that his own consciousness was bridging the frequency of the altered bodies to Source. Visualize the re-paired perfect pattern over the damaged one until you force the vision until the damaged version no longer exists in your mind's eye.**

So with Marcel's intention of consciousness, the crystal being a bridge across all the densities connected to Source, which is at a level of perfection, allowed that to resonant across the spectrum of densities to bring the dissonant pattern (the illness) at the lower density into Source resonance, since the universe tends to the perfection of Source healing occurs. Is that correct?

**JH 30/05/2024: It repaired the frequency from dissonant to resonant. As for age reversing, which can be done on either a perfectly paired body or a dissonant body, it is holographic time entanglement. Healing and age reversing are two different techniques, knowing that age holographic**

reversing can also be used as a re-pairing technique. There are many ways to get the same result, it depends on who is operating.

---

**S (S = Science based)** The crystal is rotated clockwise until a resonance is felt

My question is, is there an angular resonance of the crystal's lattice structure with a person's etheric field?

**JH (21/04/2024): No, as the etheric field is a torsion field in constant movement.**

Since you confirmed that this rotation resonance of the crystal was science. Then the question is, if it is not the etheric field, what is this angular resonance attuning to when the crystal is rotated to a point of resonance? Can you elaborate on this mechanism of the crystal's angular resonance?



**JH 30/05/2024: I haven't been trained to be a healer, but what I know is that this rotation excites electromagnetic particles and creates a mild ionization. This is locking on the dissonant pattern I suppose.**

---

Reference your procedure for working on someone else:

**-Clear the crystal.**

**-Stand relax with no muscular tensions and so does the patient in front of you. Facing each other in parallel fields. Calm of mind and of heart. Ask the patient to breathe slow and deep and generate enjoyable thoughts in order to elevate their consciousness frequency.**

**It takes the time it takes to set these conditions up.**

**-Open the vortex of the crystal first.**

**-Open your own pineal vortex.**

**-Visualize the wounded area. Bring it from your physical eyes to your pineal eye.**

**-Create the re-paired holographic version within your mind.**

**In your pineal eye. Because it is open, you are imprinting this in source.**

**-Imprint the repaired version into the damaged version, in your mind's eye.**

**-Project this re-paired version into the crystal's eye.**

**-Point the 60 degree angle to the wounded physical area of the body of the patient with winding movement clockwise. Until you feel it is casted into the morphogenetic field of the person.**

**Breathe into the crystal and the same time, regularly, the repaired hologram from your mind's eye. The crystal is the bridge.**

Would the following procedure which is modified from the above be the best procedure for a person to work on themselves?

-Clear the crystal.

-Stand relax with no muscular tensions, Calm of mind and of heart.

Breathe slow and deep and generate enjoyable thoughts in order to elevate your consciousness frequency. It takes the time it takes to set these conditions up.

-Open the vortex of the crystal first. (*finger pressure or 20 Hz metallic technology or ether?*)

**JH 08/june/2024: Don't forget about the pulsed breath carrying the consciousness interface.**

**Finger pressure is good when you work organically within your biofield. It is the easiest, as the self-healer feels more at ease of move, and "one" with the crystal. Organic body to crystal body.**

**It is a total merngence and complete interface as the electromagnetic field of the body and of the consciousness of the person interface with the electromagnetic field of the crystal lattice and of its consciousness. There is no physical atomic barrier between the two.**

-Open your own pineal vortex.

-Visualize the wounded area. Bring it from your physical eyes to your pineal eye.

-Create the re-paired holographic version within your mind.

In your pineal eye. Because it is open, you are imprinting this in source.

**JH 08/june/2024: yes my friend good point, you understand.**

-Imprint the repaired version into the damaged version, in your mind's eye.

-Project this re-paired version into the crystal's eye.

-Point the 60 degree angle to the wounded physical area of your body with winding movement clockwise. Until you feel it is casted into your morphogenetic field. Breathe into the crystal and at the same time, regularly, the repaired hologram from your mind's eye. The crystal is the bridge.

**JH 08/june/2024: this is a perfect method, I validate.**

Any suggested changes on this procedure for working on yourself?

**JH 08/june/2024: "Create the re-paired holographic version within your mind": many Terrans will not understand how to do this, you need to explain to them how to properly construct a hologram. To give birth to a viable idea, to be a creator of your reality, you need to know how to create holograms, just as the universe does. Teach them how to create a holographic vision in space, visible from all its aspects, details and directions. You know this but you need to be clear with them, as they have sometimes difficulty to comprehend if not explained in details. You want to make sure every Terran understands this tool that is in their mind.**

In opening the vortex of the crystal, are you referring to repeatedly pressing with the fingers in the area of the eye, or using the metallic silver electrodes at 20 Hz or ether method?

**JH 08/june/2024: all methods are effective; the subject may choose the tool they are most comfortable with.**

In this procedure we are using the vortex eye of the crystal, would you still advise that the crystal be cleared beforehand?

**JH 08/june/2024: of course, always, it is best. Although, it may work also when not cleared, but you want to start a job with clean tools.**

"In your pineal eye. Because it is open" Are you referring to the crystal vortex eye or the eye of the pineal gland being open?

**JH 08/june/2024: the pineal gland.**

When you “Project this re-paired version into the crystal’s eye” with the 20 Hz pulse the vortex is always open, but when using the fingers to rapidly compress the crystal to temporarily open the vortex to imprint, I would assume you could project the re-paired image into the eye synced with pulsed breath and intention and it is good to do it repeatably to support the imprint to come into formation?

**JH 08/june/2024: I agree this is right.**

---

**Questions from the science team:**

**Kent:**

I would love to hear Jen Han describe at length the physics of Phryll and longitudinal waves. Compression and aether, etc.

**JH 08/june/2024: Dear Kent, I may do this one day when I receive validation. I am not a member of the Galactic Federation technology program for Terra that has been validated by the High Council. That program is run by the Ummite and the Emerther. I am only authorized to answer specific questions. It is frustrating at times to have to limit the information I give you, but I must abide by the Prime Directive as I am Federation personnel. Dan was contacted by the program years ago, which is why I was authorized to communicate with him. My assistance is limited. However, I could apply to the program, but it is a very rigorous and vetted application, and it requires a great deal of availability. I am a terraformer on Tyr and have already applied for a new mission, which is a transfer to an Altean mothership when my mission on Tyr is completed.**

---

With the horizontal laser testing, should we expand the beam into a large area to yield a broad coherent speckle pattern that is disturbed by the Phryll? Rather than using two concentrated beams interfering?

**JH 08/june/2024: I would recommend you try expanding the array.**

---

**Chris:**

In my theory, gravity is an aether wind sucked by matter. This is verified by the Michelson and Morley experiment that has measured a maximum aether speed of 11.2 km/s like the escape velocity for the earth equal to the speed of a body in free fall from infinity. The big question is :  
Where does the aether go ? Where does its kinetic energy go ?

**JH 08/june/2024: the ether is transformed into energy. It generates a compression wave that radiates back. This is how we harvest it. The ether never disappears to reappear somewhere else; it is transformed when encountering the electromagnetic field of a solid body. You speak about a planet, but consider a human body. The ether is also interfered by the human body and the human body creates gravity. Not in a great amount that can be detected by your instruments, but it does. At the scale of a planet, you can easily experience it and measure it. Quantify it. When we harvest Phryll in space, it is done by the kinetic movement of a ship. In a similar way to an electric or a mechanic compression pulse activating a crystal to generate Phryll, a movement through the ether field excites its particles and energy is born.**

---

In my current understanding, its kinetic energy is transformed into compression/scalar waves, and the aether has to go somewhere. If scalar waves are the core means for teleportation and connection of 2 points in space, I assume that protons connect to another point in space and this creates a micro stargate. Is this correct ? What are the correct answers ?

**JH 08/june/2024: Teleportation is the system by which the Stargates operate. Scalar waves do not enter the process of teleportation: it is a transfer. Think of the universe not as a continuum of matter, but as a non-linear field of particles. Space is not flat, it is a field that extends infinitely in all directions and also out of linear time. Connecting two places works through the field. In this field, all places exist at the same time, just as all times exist at the same moment. In the field. The force contained in the field holds all universes together. The field is the nervous system of the body of Creator.**

---

About the understanding of physics, I have a question about densities :

Our quantum physics is based on the Planck constant named  $h$ , where the energy of a photon is given by this simple formula :  $E = h \times \text{frequency}$

Up to now, our official physics recognizes only one value of  $h$ , and does not explain what densities are, and what raising its frequency means.

In my current understanding of aether physics, raising its own frequency would lead to a different  $h$  constant, which is smaller. Is this correct ?

**JH 08/june/2024:  $h$  is a variable. If it were a constant, creation couldn't exist, because everything is first created at the highest density and then fractalized into matter. The Creator breathes through the octaves of density. Outward into the field of creation and back to the original singularities. And so on. Eternally. The journey of life exists because  $h$  is a variable.**

## Jen Han Eredyon Session – 12/06/2024

I imagine there could be different approaches for using the vortex eye of the crystal for healing work on ones self. Could this be one of them, or would you recommend a different approach?

Pointing the emitter end of the crystal toward the wounded area of the body while projecting a visualization of the wound being already healed while at the same time compressing with fingers the area of the eye in sync with breath pulse to project visualization. This is done repeatedly to help reinforce the casting of the healed vision into the body's morphogenetic field.



Any suggestions for improvement on this procedure?

**JH (June 12 2026):** As I said, I'm not a medic, so I don't know all the healing methods that require crystals. I just know the basics of how it works. The method you read to me again, Elena, is a good method. I know there are simpler ways, such as projecting a new holographic construct directly from your consciousness into a crystal, but I am not familiar with those methods. Any method that involves projecting a resonant pattern into a dissonant area is effective. There are many ways to do this. Compression waves impulse always activate the area of the crystal where the vortex is. Around this basic action, the technology involved is variable. Compression waves may be thought, physical pressure, electric signal, and many other ways.

---

### How to illustrate the area of the void?

I wanted to illustrate the area of the void. My understanding of the flower of life pattern of the multiverse is made up of dimensional spheres or bubbles, and that each bubble extends into the center of each adjacent bubble in all directions at an angle of 60 degrees to each bubble.



If the bubbles project themselves infinitely in all directions, which I am assuming, the overlapping of the adjacent bubbles does not appear to allow for any unfilled areas for the void to exist, only overlapping bubbles. I know I must be missing something. Can you help identify how the void is created outside of these bubbles of the multiverse?

Some Terrans believe the area of the void appears as below. But this does not make sense if bubbles are overlapping in 6 directions as well as from above and below that would fill all gaps between them.

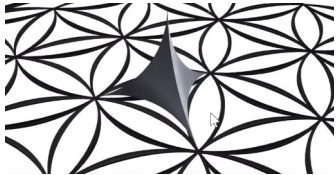

**JH (June 12 2026):** The pattern that you see, represented as a two-dimensional plane, is the formula for the Creation. Creation is organized and grows on this holographic pattern.

Please remember: Creation is active, it is constantly moving; it is expanding into infinity in a non-linear space. The space between universes is, in truth, the Void. The void is also a nonlinear space. It is contained between the universes. Understand the term: "between" as a buffer space located between existing objects (two or more universes). The void is a network. While you can visually understand from the two-dimensional representation of the Flower of Life that all universes seem to touch, in the reality of Creation they do not always intersect.

Some universes intersect with one, two, or six other universes. I understand that this is difficult for a mind living on linear time in linear space (on your planet) to comprehend. In the two-dimensional representation of Creation, think of the lines also as buffer spaces between universes. Some universes will have longer scales of density, so they will grow larger and overlap with many more universes than universes made of a shorter scale of density. There are always gaps, and these gaps fluctuate. Because the Void is essentially a nonlinear space, it is a quantum pervasive medium, to use the terms of your scientific vocabulary.

ELENA: is it correct to assert that the demarcation lines between the bubbles intersecting are also a buffer space?

**JH:** It is.

ELENA: I try to explain to Dan that the universes are not absolute spheres, but he doesn't understand how this assertion doesn't fit in the pattern of the Flower of Life, which I call a blueprint of Creation.

**JH:** He has to jump out of linear vision. He needs to close his eyes and visualize it in his mind instead of trying to fit a multidimensional reality into a two-dimensional image. Dan likes to calculate angles and mathematical ratios, but in this case, although the two-dimensional map of the creation shows the angles, the universes and how they intersect do not operate at the same exact angles because the shapes of the universes are constantly moving. The geometry of the Flower of Life is a mathematical equation of Creation, not a photograph of what the Creation really looks like. Take the skeleton of a creature and see how flesh, feathers, and hair grow from those bones differently from creature to creature, evolving with an infinite variety of shapes on the fractals of the numbers 1 1 2 3 5 8 13 21 34 55 89 144. Every universe has its own personality and its unique morphogenetic field. Have you ever wondered why in the Anakh universe all life forms tend to have an elongated skull? And why it is not a common occurrence in this universe?

ELENA: yes, I have.

**JH:** There you understand. Tell Dan to close his eyes and visualize the bubble universes as moving entities, intersecting each other. Tell him that the geometry called the flower of life is the stem structure upon which the creation articulates. This two-dimensional geometric pattern is also a mathematical reference that gives the frequency codes for DNA, terraforming, and consciousness. It articulates everything that exists in the creation, from the infinitely big to the infinitely small. It is the stem structure of everything. It gives the ratio of how Phryll comes out of the Void.

ELENA: Jen Han thank you, we will come to you if we have more questions.

---

## **Oona Session on healing with crystals – 15/06/2024**

Oona is an emissary for the Altean delegation of the Seeders, a cell of scientists from the Intergalactic Confederation

### **Elena:**

Oona has been traveling from a trip she made with her partner Tayel to the Aldeerand galaxy. Everyone deserves holidays right! We had a telepathic conversation while she was in their little ship traveling back to the Sol system. She said she would be here " in a few days". In the meantime, she told me this.

### **Oona:**

Be the crystal. Imagine that your body has the form and consistency of a crystal. Crystals vibrate faster than light and have consistency in every realm that light traverses. Crystals are bridges by their very nature. They are a gift to the multiverse of creation, but also the tools of the Creator. We imagine being them when we wish to heal ourselves and we begin to vibrate faster than light. It will reharmonize all of our cells to the vibration of light, and the DNA bonds that are broken will be repaired. As you know, a wound is broken tissue. To repair an injury in your flesh, you need two procedures: the first is to send out frequencies that will neutralize unwanted microbial life, such as infection. The second procedure is to mend the tissue. This is done by crystal technology or by the power of our minds. I am an Altean. I can look at a wound on my body and heal it with the simple power of my mind. For I will send very specific thoughts, with a holographic projection of the repaired area, carried on a binding brain frequency.

Using crystals that are in my head. I am human, the body you occupy is too, so you can do it as well with training but you would have first to declutter your brain organ. You call that place the pineal gland. You know much about this.

Use crystals as an external tool, but not as part of an external technology, as you asked. Crystals are bridges. Even though they have a form of consciousness, they are still bridges. Make friends with one of them: that is, connect two consciousnesses. Place it on the wounded area and ask it to vibrate its frequency within the broken bonds of the affected area. Create a current with your brain waves that induce a current. Like a wind blowing from your mind.

The crystal is a bridge to Source Creator when it comes to healing. I am talking about physical healing as well as emotional healing. It bridges your consciousness to the disharmonious area through Source consciousness. This is what the creative frequency of Source does by nature, the re-harmonizing and repairing of the wounded area.

Practically, with a crystal in your hand as a tool, project your holographic vision of the repair to be made into the central vortex of the crystal. It will connect to Source and bridge the creative frequency of Source in the holographic thought you imprinted in the crystal to the target.

Several elements come into play:

Source is the healing frequency, your consciousness gives the impulse order. The crystal bridges your conscious thought to the target by connecting to the creative frequency of the Source. Use it like water:

Source Creator is the medicine. Your consciousness is the water that carries the medicine. The crystal is the tool that pours the medicine water onto the target.

We touch the target with the top of the crystal or rotate the top of the crystal over the target. We also have the crystal chambers, remember? We can lie in there and bring anything dissonant back to its harmonic state.

## Jen Han Eredyon Session – 26 JUN 2024

### Regarding creation's non-linear forming which stems from an exact fundamental formula:

Thank you Jen Han for clarifying that the flower of life pattern is essentially the formula for creation which is based upon exact mathematics derived from the nodal points within the flower of life pattern

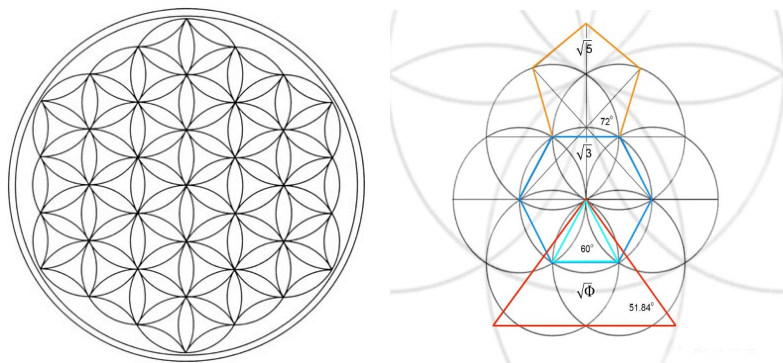

My previous misunderstanding was that the spheres or bubbles of the multiverse were based on this pattern of geometrically exact overlapping spheres in all directions into infinity that would look like this below image in order to maintain these exact mathematical ratios.

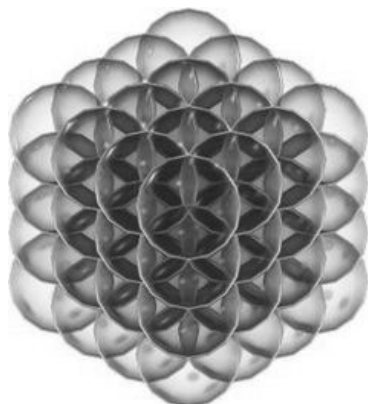

In actuality, as you said, “Creation is active, it is constantly moving; it is expanding into infinity in a non-linear space.” Since the Void in which all these spheres exist is in non-linear space, this non-linearity produces dimensional bubble like spheres of varying densities which are not all equal in size which fluctuate and overlap to varying degrees with other spheres, allowing gaps in which the Void can reside. So the spheres of the multiverse appear more as varying sizes of wobbling bubble like spheres as Elena actually witnessed on Prince Ea’s ship, as she viewed what Source appears as, which Elena attempted to illustrate below.

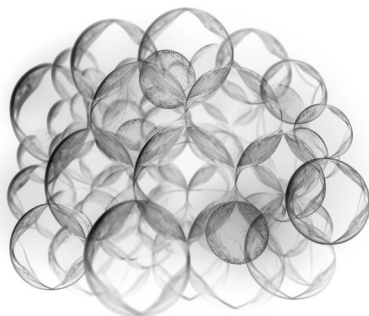

This is evident in how all of life has a unique morphogenetic field that is fundamentally based or stems from the exact mathematical blueprint of the flower of life, but manifests its forms as not an exact ratio of it, but rather approximations of Phi ratio fractals in an infinite variety due to operating in the non-linearity of space.

As everything in creation has its opposite, and both are vital for both to exist. It appears that the precise mathematics within the flower of life pattern have their exact opposite counterpart in the non-linear expression of creation. Just as Void and matter are opposites and need each other to exist.

Do I have this understanding correct?

**JH (26 June 2024): You have. What is to understand is that the core fractal structure in infinite within and infinite without, with a movement from within towards the without. The sphere universes evolve and grow, as all Creation does. Void and Matter are opposites, that is true and works accordingly to the greater laws of Creation. When you create something, the opposite exists instantly somewhere in Creation. It is all about balance.**

### **Regarding how matter comes into formation:**

Jen Han, do I understand correctly? that when you imprint from your pineal vortex into the open vortex of the crystal, that because you are connected through your consciousness to the singularity of the open vortex which is connected to everything which is the Void, and that the Void is quantum entangled directly to the level of Source, which the crystal acting as a bridge by being resonant on all densities allowing Phryll to emanate through the crystal. Since Source is the highest density and that Phryll bridges Void to matter, is the imprinted program that is placed into the Void, which uses the keys of the morphogenetic grid lattice structure of the universe to allow it to come into physical manifestation on a lower density due to the Phryll bridging from Void into matter. Phryll comes from the Void through the geometry ratio of the flower of life blueprint into physical matter.

In other words, the projected program exists for eternity in the Void, which forever writes this program into the lattice structure of the universe which you are in at the level of Source and all of its sub-densities to support materializing into physical reality?

Why is it that the higher harmonics of densities affects the low densities, but not the other way around?

**JH (26 June 2024): because Creation tends towards growth and evolution. Source stands at the highest point of evolution, as the near-perfection. It creates constantly, radiating outwards fractals of consciousness. If the lower densities were affecting the higher densities, it would cause destruction. Evolution is one way, in its duality.**

### **How to know when you are connected to the Void:**

You once said regarding connecting with your mind to the open vortex in the crystal...  
“You can also feel it with your mind, where the power center is. Your being recognizes it. It pulses faster than light, your body and being recognize this. They feel it.”

How would you describe the sensation when your pineal vortex is connected with the open vortex in the crystal so that you know you are connected?

**JH (26 June 2024): You suddenly know it. It can be experienced differently regarding individuals. To me, it is felt like a sudden clarity, a breath of fresh air and a greater lucidity. I feel a slight tingling in my head. We, Humans, across all the races of our species, on any world, have this vortex gland. Reptiloids and Dow (The Grays), do not have it. That is why they cannot access what we are able too.**

I understand that it's important to prepare beforehand in order to achieve higher gamma brainwave levels. Method I've been using has been a short meditation using 40 Hz gamma in binaural headphones

Is there a local field of the open vortex in the crystal when it is activated, that you need to be a certain distance from it in order to sense it and connect with it?

**JH (26 June 2024): it depends on the size and capacity of the crystal; the field will vary. Again, you will feel the field with the palm of your hands.**

### **Achieving saturation of the crystal by sequencing frequencies to open the singularity**

In sequencing the frequencies of 10-20-30-50-80-130-210-340-550 Hz to reach saturation and be able to detect the "singing" of the crystal using 20 volt pulses, we had as of yet no result.

You recommended the following:

"In the Earth's electromagnetic field the measurements are different. It is different on every planet. Try pulse a higher voltage, such as twice the impulse."

Kent said that he increased to twice the impulse to 40 volts and even up to 60 volts, but no reaction of the crystal was detected. This is something we were hoping to demonstrate this reaction to the Terrans as a measurable effect by using the frequencies of this ratio formula of the curvature of a wormhole to saturate and cause it to audibly "sing".

If even at 60 volt impulses we are not getting the reaction, can you think of any other approaches we might try to obtain this effect? Would the time duration on each of these 9 frequencies need to be adjusted, such as 1 to 10 seconds on each frequency before switching to the next higher frequency? Possibly even a higher voltage or to try a different crystal?

**JH (26 June 2024): I would have to ask for advice. Perhaps your instruments cannot detect the Phryll. All life around should benefit from it and feel it. Perhaps you are being protected by higher forces, for it is my concern that if you can publicly demonstrate how to provide energy from crystals, you will be in deep trouble. However, the time has come to break the secrecy. I would boldly persevere. I will ask my colleagues what might be wrong with it. There are two Ter-ran engineers on my team. They know Terra's readings better. I am sorry I cannot be of further assistance today. We will talk again.**

## Oona Session on healing with crystals – 02-JUL-2024

Oona:

A certain quality of quartz crystals, of pristine high purity, animated by its own consciousness, vibrates not only on the lattice of space, but also on the lattice of time. The frequency rate between atoms is not a wave, but a quantum entanglement. The impulse is non-linear, there is no lineal exchange of information. That is why quartz is a transponder by nature. It connects points on the grid of space, but also points in time. Your science will soon discover this. Quartz is the highest state of solid matter before the state of light. That is why quartz can heal tissue.

It doesn't reorganize matter on a molecular level, but it repairs it by transponding the injured organic tissues with the vibratory key of a previous state before the alteration was made. It reorganizes dissonance with a resonant template. The entanglement is done by the intention of the healer, unless the crystal's own consciousness is trained to do it automatically.

You are the first to receive this information. (Received July 2, 2024)

Note:

This is an exciting new understanding from Oona. That quartz crystal through quantum entanglement vibrates throughout the lattice of time. Therefore it not only transponds your current avatar template at this current point in time, but it also connects to all of your previous avatar template states throughout time. Since the universe tends to perfection, the most resonant template version of your previous self that still exists in the lattice of time, will have the most predominate effect because it's template is the closest to perfection and will quantum entangle to your current avatar template, causing it to morph from it's current dissonance to the previous more optimal template state that was the most resonant. This action is being directed by your intention to do so.

## Jen Han Eredyon Session – 16 AUG 2024

Hello my dear friend on Tyr, as always, I wish to express great gratitude for all you have shared with us. I understand that your next duty station will be upon an Altean ship to expand your knowledge even further, of which I am happy that you have such an amazing opportunity to learn so much. I have only a few clarification questions if you could be so kind to answer.

**JH (aug16/2024):** Salutations to you, my great Terran friend Dan! It has been a long time since I have responded to your questions. I was away for a while on one of the Altean ships; Oona found this student position for me. It was a very informative experience and training where I learned more about the etheric capabilities of crystals, especially a very rare and pure type of quartz that can only grow in an antigravity environment. The growth of a crystal in mass cancellation makes them round and faceted; they do not grow as points and the lattice structure is organized differently. It is not based on the laws of gravitational variables, but on pure matrix geometry.

You can actually see the pattern of the universe, I mean creation, in the large ones. They are extraordinary; only the Alteans grow them, for the seed-roots of these crystals come from their original world. Their properties are not suitable for terraforming; the Alteans use them more for consciousness work, and also to build the core receptacle of their ships, where the ship's consciousness drive is embedded. It's fascinating, when you look directly into these crystals, you can see... it's like you can reflect your own consciousness, they're like mirrors of the universe. No wonder these people are skilled in crystal science; they grew up in an environment where these things grow! They have been bathing in the frequency and consciousness of the seeds of these crystals since childhood. You know, these seeds, they take them into space and they replicate them, and then they grow the replicas in non-gravitational conditions. That is when they create them. But they don't share that secret. You can go to their world and get those seeds, but to grow them in space, well, you have to know how to do that. They don't need technology; they do it with the power of their mind. That's why nobody else can do it.

### 1) Reference to previous exchange:

“Achieving saturation of the crystal by sequencing frequencies to open the singularity”

Dan (26 June 2024):

In sequencing the frequencies of 10-20-30-50-80-130-210-340-550 Hz to reach saturation and be able to detect the “singing” of the crystal using 20 volt pulses, we had as of yet no result.

You recommended the following:

“In the Earth’s electromagnetic field the measurements are different. It is different on every planet. Try pulse a higher voltage, such as twice the impulse.”

Kent said that he increased to twice the impulse to 40 volts and even up to 60 volts, but no reaction of the crystal was detected. This is something we were hoping to demonstrate this reaction to the Terrans as a measurable effect by using the frequencies of this ratio formula of the curvature of a wormhole to saturate and cause it to audibly “sing”.

**JH (aug16/2024):** You may not hear it sing when Phryll is produced; only when the flow of Phryll saturates in the crystal.

If even at 60 volt impulses we are not getting the reaction, can you think of any other approaches we might try to obtain this effect? Would the time duration on each of these 9 frequencies need to be adjusted, such as 1 to 10 seconds on each frequency before switching to the next higher frequency? Possibly even a higher voltage or to try a different crystal?

**JH (aug16/2024):** Have you tried increasing the voltage? I now know what the voltage measurement scale is, my Terran colleagues on Tyr explained it to me. On Tyr, they do not use Terran scales, but Federation scales. We need to align our scales of measurement within the Galactic Alliance.

**Jen Han (26 June 2024):** I would have to ask for advice. Perhaps your instruments cannot detect the Phryll. All life around should benefit from it and feel it. Perhaps you are being protected by higher forces, for it is my concern that if you can publicly demonstrate how to provide energy from crystals, you will be in deep trouble. However, the time has come to break the secrecy. I would boldly persevere. I will ask my colleagues what might be wrong with it. There are two Terran engineers on my team. They know Terra's readings better. I am sorry I cannot be of further assistance today. We will talk again.

**Dan (18 July 2024):**

Were you able to get any answers from your two Terran engineer colleagues? A method to measure the Phryll with any suggested Terran equipment they know of would of course be most welcomed!

To clarify the previous question, the objective of that question was not to measure the Phryll or provide energy from the crystal, but to simply measure the audio being emitted as a result from the crystal “singing” once it reached saturation from sequencing those frequencies, at which point we would immediately disconnect as you had advised. The purpose is to demonstrate to the Terrans that there is a measurable effect from the information that you have graciously shared, even if it is only an audio sound as a result, as we do not yet have a means of measuring the Phryll being generated.

**JH (aug22/2024):** I have asked them, before I left for the Altean ship. They said they didn't want to get involved but one suggested light interferometry and the search for distortions. You know they are well aware that passing on this type of technology to Earth civilians is not part of their clearance; they risk their job on that. My Terran colleague, Charles, I feel he is willing to help but at the same time he doesn't want to risk his position of engineer. I will be open to hear from him if he decides he can help.

This would provide a physically measurable proof and corroboration of the information you shared and would help to provide credibility in the minds of the Terrans that these communications through Elena are real and valid.

**JH (aug22/2024):** I am very sorry nothing from my side can be done in that matter. Thor Han advised me to be very careful not to cross some boundaries. And you know, on Tyr, there is a lot of surveillance. These Terrans have no trust in each other, unlike in the Federation where work is based on a community spirit and on mutual trust. I don't understand Terrans sometimes. We are now six

Federation personnel in that environmental engineering team, and they look up to us with admiration. Charles said they are impressed by how we are calm. Well, why stress? We are happy to work together.

The second purpose would be to possibly provide a means of saturating the crystal with Phryll which could then be induced into our bodies by holding the crystal for healthful beneficial purposes.

**JH (aug22/2024):** Dan, listen, the gravity waves of your thoughts can just do that. It is all a matter of increasing the power of the scalar waves, whatever their nature is: electrical intensity may be increased. Your mind does that as well. It is not the proper electricity but the gravity waves it generates that animate Phryll when crossing through an environment filled with Ether.

**2) Dan (18 July 2024):**

Elena and I have updated the crystal holding structures for our crystals that are being pulsed at 20 Hz from our signal generators to the pure silver electrodes across the central vortex of the eye which we term a “Reality Modulator” to differentiate from the “Phryll Generator”. The crystal is sandwiched very lightly between two clear plastic discs supported by three posts to allow it to oscillate freely in the structure.

**JH (aug22/2024):** I had to ask Elena for sandwiched. Nice holding structure!

Originally I could not locate the correct non-metallic threaded posts and had to use the metal brass, whereas I sent Elena one with non-metallic nylon posts to assemble. Would you recommend that I replace the brass metallic posts with the nylon ones like Elena has to be more effective?

**JH (aug22/2024):** I would opt for rather non-metallic poles.

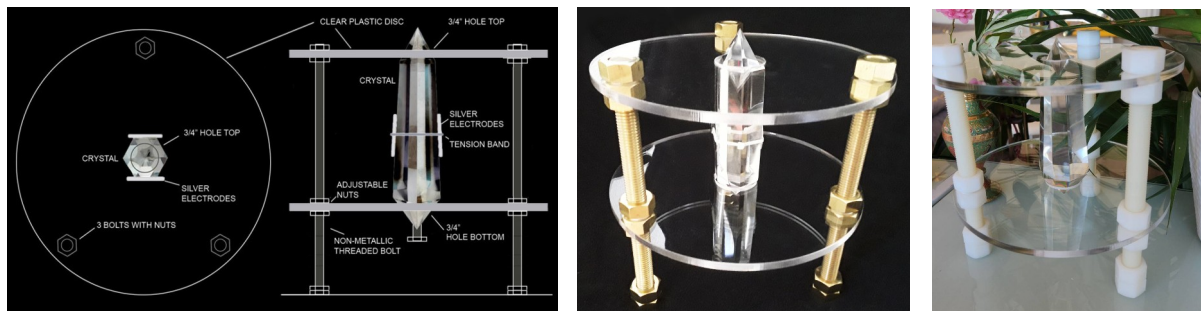

**3) Dan (18 July 2024):**

I have gathered from our previous exchanges, that the “Reality Modulator” which allows the vortex eye to remain open due to the continual pulsed compression waves at 20 Hz, is more effective at interfacing with consciousness due to the vortex being always open compared to finger pressure across the eye.



What would you recommend would be the most efficient way of applying finger pressure to temporarily open the vortex eye in sync with your breath pulse and projected holographic vision to imprint into the singularity of the void when the vortex momentarily opens? Is much pressure required on the crystal to accomplish this and should it be a quick rapid squeeze as to simulate more of a pulse?

**JH (aug22/2024):** The pulse must be firm and sharp if it is only mechanical using only the pressure of your fingers. If coupled with a conscious visualization that your mind sends electrical impulses through your body, through your fingertips, the pressure needs not to be very strong.

**4) Dan (18 July 2024):**

Wish to confirm that I understood correctly in the process of clearing the crystal with the 4096 Hz sound frequency, that it is only required to expose the sound to 3 of the 6 sides of the crystal to oscillate the 3 axes, or should all 6 sides be exposed? I'm assuming the clearing process to take less than 30 Terran seconds to remove previous imprints?

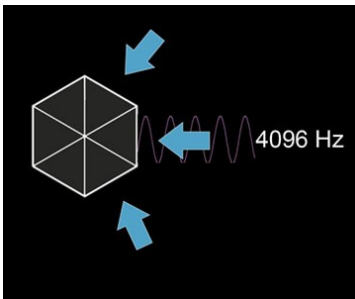

**JH (aug22/2024):** three sides is good, but if the crystal is difficult to clear because heavily polluted, then proceed on the six sides. For every day's work with a crystal, a short, quick, scan with the clearing device is enough on 3 sides.

**5) Dan (18 July 2024):**

Our first design "Phryll Generator" in which Oona reported had a "feeble" level of Phryll generation, had a crystal whose termination angles were several degrees off at 62 and 55 degrees. Using a solid design coil form for the torsion field coils that were pulsed around 40 volts



Version 1

Our new prototype Phryll Generator which I just placed the silver and copper winding onto is a more open style framework coil form designed by Chris. It has a re-cut crystal that is very close to 60 and 51.8 degrees and will be pulsed with a higher power supply by Kent to provide 95 volt pulses.

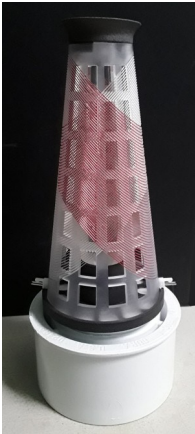

Version 2

This will be the Phryll Generator that I will be doing the comparative plant growth experiment with that will expose one plant to the Phryll of the generator and the other will be the control that is not exposed. Do you think with all these improvements we may be able to achieve greater than previously feeble Phryll generation?

**JH (aug22/2024):** I do not know my friend. The angles of the crystal sound perfectly well fit for the experiment. But it seems you are moving forward very well. On the Altean ship I have seen one of these powered by a magnetic ring that had inversed charge on one half and it was turning on a metallic plate, horizontally, at the base of the crystal. It powered the coils by electromagnetic charge transfer. The crystal produced light. I cannot tell what metal it was but when you approached your hand, you could feel the magnetic field generated by the ring. It had the size of a man's bracelet and had a rounded section.

**UPDATE WITH TEST RESULTS:**

**Dan (5 Aug 2024):**

The following Phryll exposure to plant growth experiment was performed using wheat, barley, oat and rye seeds that were continually exposed to the Phryll generator from planting to sprouting in identical conditions. To enhance the Phryll generator a bowl of water is next to the Phryll generator.



There was no noted difference in plant growth compared to the “Control”



Afterwards the two grass plants were given to our kitty (Shambhala) where she would start to eat the “Phryll Exposed” but would stop and go over to the “Control” which she appeared to prefer.

Interestingly in Paris, Chris was testing with Phryll impregnated water circulating around his Phryll generator. Insects attacked his “Phryll Exposed” and left the “Control” alone.

**NOTE from Elena:** The same thing happened with my plants in Ireland exposed to Phryll: an overgrowth of all sort of life forms, including green flies infestation from out of nowhere. That is maybe why Dan's cat preferred eating the non-exposed one. Cats know these things.

These test results indicate we have done something incorrectly or are missing a crucial element in order to be successful in truly generating Phryll and the beneficial effects you have indicated.

**6) Dan (18 July 2024):**

Oona shared a healing method technique and stressed the importance of first clearing out our pineal gland. She spoke of using our conscious intention to heal the target area by instructing the crystal to bridge to Source and deliver the healing resonance from Source via the crystal to the target area.

Oona, being a highly advanced Altean, appears to automatically activate the central vortex in the crystal in this procedure without the need of any finger pressure as us Terrans need to do.

Since you've been on their ships, do the crystals they use that are formed in alignment with the lattice structure also use the 60 and 51.843 termination angles in order to create the central vortex?

**JH (aug22/2024):** Yes they actually do. Except with this special type of crystal that they grow only in space. The vortex appears in its exact, geometrical center and it is powered by consciousness.

Oona also shared that the quartz crystal not only resonates in the lattice of space, but also in time. When one holds the crystal, she said it will transpond your current avatar template by quantum entanglement. Since it resonates through the lattice of time, it also resonates all of your avatar templates that have been recorded throughout the lattice of time. Healing of your current avatar occurs due transponding the resonance of a previous template that was most optimal. Since the universe tends toward that perfection, the avatar template that is the most resonant will tend to predominate and transpond the vibratory key of that more resonant template onto the current template to bring what is dissonant into resonance with it. This is activated by the intention to do so she says. Is this your understanding as well?

**JH (aug22/2024):** I have learned many things with them, in such a short amount of time. They are not eager to share their secrets of power easily; they want to make sure at first they can trust your civilization, that your people won't use that knowledge for harmful purpose. The Alteans have, it is true, ability to heal themselves, I would say "re-pair", but the simple power of their intention. They are so much evolved that they sort of merged with crystals, not physically of course but in frequency, consciousness, and abilities. What their mind can do is similar to the properties of quartz. The civilization to which I belong still needs technology in order to use the potential in the crystals. But the Alteans don't. It's with their mind. So she showed to you how they heal themselves but with using a quartz crystal, that is great. They also are you know, different. They belong to what we call a collective consciousness, they can synchronize their heart beats in a group, a crowd, an event, an interconnect their thoughts. I wonder how it feels, you must hear all these voices, all these thoughts... Vibration in time allows to pair the resonance of a dissonant body to that of a better version of it. Crystals do this. And you can guide it with your consciousness.

## 7) Dan (18 July 2024):

Reference:

Jen Han (08 June 2024):

“Create the re-paired holographic version within your mind”: many Terrans will not understand how to do this, you need to explain to them how to properly construct a hologram. To give birth to a viable idea, to be a creator of your reality, you need to know how to create holograms, just as the universe does. Teach them how to create a holographic vision in space, visible from all its aspects, details and directions. You know this but you need to be clear with them, as they have sometimes difficulty to comprehend if not explained in details. You want to make sure every Terran understands this tool that is in their mind.

I know these mental exercises need to be developed in order to effectively alter reality.

Have you any recommended exercises to help in creating holographic visions in space?

**JH (Aug. 31/2024):** I told you already: you need to create a holographic vision with your mind, inside of your mind, and project it through brain waves into the crystal or either into the holographic matrix of reality.

**Elena:** Jen Han, you and I know how to do these things, but Dan is asking if you could break down, step by step, how to do it. How to construct a hologram using consciousness, and then how to project it. Dan wants it as a detailed procedure. Imagine you would write this for a science test.

**JH (Aug. 31/2024):** Hey not a worry, I can do this. Listen. At first, you need to...

**Elena:** Please do it like a list with bullet points.

**JH (Aug. 31/2024):** No problem big sister.

-Manifest in your thoughts what project you want to create.

-Once you are sure and the idea is clear, I mean the intention, you can start creating it. If you can describe your project with words, you can create a hologram from it. If your thoughts are not clear enough that you cannot describe your project by words, so no hologram will come of it.

-Close your eyes.

-Breathe calmly.

-Smile gently to destress your face, head and nervous system.

-Feel tingles in your chest generated by a feeling of contentment and happiness. You are happy to be here, just that.

-Think about your project. Now, conscious thoughts are going to replace the descriptive words. You should try with a cube as an exercise and then switch progressively to more complex objects like a flower. Physical objects. Concepts are a superior level. Start by simple objects. Here is a good one, with a flower, rather.

-Intention: you want a flower in your hand.

-Create the flower following this guideline:

-Eyes closed still, visualize with the power of your imagination a beautiful flower, on the black background of your eyes closed. Notice: that darkness in front of you is not the solid screen of your eyelids but an infinite medium allowing infinite possibilities of creation.

-You see this flower floating, inside of your mind's eyes, and be aware that it is not a hologram but a rough, blurry, non-detailed idea of a flower. This is the template. Now you are going to create the hologram.

-Focus your thought on the stem and make it turn, that you see all its facets in all different perspective. Be aware of its composition, moisture and smell. How does it feel when you touch it with your fingers. You created the hologram of the stem.

-Focus now on the petal. It is growing from the stem and feel its moisture, smell and touch. Construct the petal with your mind and now turn the construct around to materialize it in your mind from all its sides.

-One by one, you add the petals. Same idea, you look at them from all direction.

-Create the ovary, style, stigma and pollen stamen in a way that you can look at the flower in transparency and see every functioning elements are there.

-Now put everything back opaque

-You created a complete flower and now, you must turn it around and visualize it from all directions, included top and bottom. You just created a holographic flower with the power of your consciousness. Now you need to imprint it in the matrix. When you are more experimented, you can create a flower in its globality only by thinking about it. You can create gardens, cities...

-Your eyes are still closed. Keep them closed.

-In your mind's eye, which occurs in the area of your pineal gland, the Creator's link, now imagine your right hand coming forward and sliding under the flower, and the flower delicately falls in the palm of your hand. The flower is in your hand.

-Move your real physical right hand forward in the same position. You know in your mind's eye that your real hand is there, ready to receive the imprint of the new hologram. You understand that you can do the same for healing yourself, yes? Visualizing a sane body part? You will understand shortly.

-The hand in your mind's eye is the hand you physically put forward. You superimpose the both, they are one.

-Open your eye and look straight at your physical hand. The flower is there as a transparent hologram.

-In the coming days, the universe will respond by bringing to you such a flower in your hand.

-Understand you can construct the hologram of a sane part of your sick body and superimpose it onto your sick body part. Consciousness does that. The universe tends towards perfection. And our minds can create perfection, there is no obstacle to it. The abilities of our consciousness are infinite, our creative power is unlimited. When you send out a hologram out there into reality, the hologram becomes reality sooner or later, carried with the tides of the universe. Time is the factor that will synchronize your holographic project into the physical matrix of Creation.

-You can do it with emotions: replace sadness by happiness. Basically, you create a project and you "project" it outside of your mind. What you look at, you connect with its matrix. That is inevitable. It works like that. Do you understand now, how the malevolent organizations on your planet have been feeding your mind with horrible visions through media supports? That you create fear around you and a horrible reality. They used you, Terrans! They used your creative power to create the world they want.

I hope I was clear enough. Make sure to understand: when you look at something with focus, you create a quantum entanglement between your thought and the target. You can then alter the target with your thought in the way you want. Physically or emotionally, or both. You know, you can create universes, you can create your future. You just have to imprint, by visual focus, your holographic project by overlapping your inner vision onto the existing reality. We even have medical technology that does that.

## 8) Dan (18 July 2024):

Reference statement:

Jen Han:

“The void allows for imprinting into the grid of the universe from which you are working. It bridges it by accessing the keys of the morphogenetic grid. But it is within the grid of the universe from which you are working that this intention is actually imprinted.”

To help understand the creative process of going from a creative vision that is in your mind to be formed into physical reality in the structure of holographic fractal matrix. I understand the importance of loving intention coupled with a creative thought, since the matrix is in an ordered state of geometrical resonance that allows a non-dissonant creative thought to transcend through all the densities into manifestation. I understand that because of this the geometrical resonance of this grid structure that does not support a dissonant thought. Because of this, it prevents the misuse of this reality shaping technology, is that correct?

**JH (Aug. 31/2024):** Imagine the result of a thought upon water, creating geometrical patterns and changing the structure of water. A thought is a scalar wave as you call it, that I would define better as a carrier wave that is an electrical impulse. Thoughts have complex geometrical patterns, with complex frequency formulas or as we can name it: frequency keys.

Is my understanding correct, that when imprinting into the crystal's open vortex that connects into the Void, that the Void is completely void of all time, space, densities, and therefore there is no lattice structure in the Void to imprint to, but due to the Void's nature of being connected to everything and especially being connected directly to the highest density which is Source, that the imprinting does not happen within the Void, but rather imprints directly at the level of Source. Since the higher densities form the lower into physical manifestation, if the vision imprint was sent into the Void through the crystal's open vortex, and nothing can be imprinted in the Void, why is it said that the imprint will last forever because time does not exist in the Void if it is not imprinted in the Void?

**JH (Aug. 31/2024):** The Void is the non-time field and the non-creation. It is a medium that stands in the lapse between the universes. It runs on the surface of the bubbles and also exists in-between them. The void does not specifically “imprint”, but it will transmit, send it to the target, as the void is empty of holographic morphogenetic field.

In other words, when a thought is projected from our pineal gland vortex into the open vortex of the crystal that connects into the void, does the void act simply as a means to connect directly to Source and imprint at the level of Source?

**JH (Aug. 31/2024):** Yes.

Source being the highest density, and since the higher densities cause formation into the lower densities, the imprint at the level of Source comes into manifestation down through the spectrum of densities into the physical realm using the keys of the morphogenetic grid of the universe we are in to bring the imprint into manifestation?

**JH (Aug. 31/2024):** That is correct.

### 9) Dan (18 July 2024):

Previous reference:

**Jen Han (21/04/2024):** Yes, when these mediums are activated, their frequency increases to that rate. The frequency of light is 430 to 750 trillion Hz in terms of the color spectrum in the universe in which we live. It is a different measure in other universes. 4096 is a fractal core measure of the frequency of light in this universe. The frequency of water is 2.45 billion Hertz. 4096 is again a fractal measure of it

Dan:

So the 4096 Hz frequency is fundamental to everything in our universe as it is a fractal or harmonic integral of it. The square root of 4096 is 64, is this related to the 64 tetrahedron grid?

**JH (Aug. 31/2024):** This is correct.

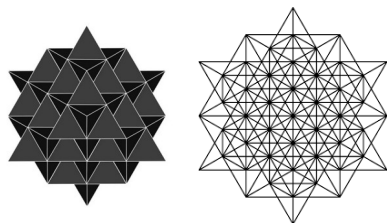

**Jen Han (30/05/2024):** Oh, Dan, you get it right. Here is the scale of creation. Carbon is one of the building blocks of organic life, as is silicon and sulfuric acid, for example. All fractals of the Source Light frequency are elements that go into the creation of any life form that can support the growth of consciousness

Dan:

So if the 4096 Hz frequency has as its square root of 64 (somewhat like a fractal expression of the 4096 Hz) and this 64 number is related to the tetrahedral 64 grid structure, is there a relationship between each tetrahedron form structure and each frequency oscillation cycle?

**JH (Aug. 31/2024):** There is.

You said the frequency of water is 2,450,000,000 Hz (2.45 GHz) and that 4096 Hz is a fractal measurement of it. What is the related math of this fractal relationship of these two frequencies?

**JH (Aug. 31/2024):** The fractal ratio is 0.0356521923094988

Thank you my dear friend for your help in understanding this science

Dan on Terra

**JH (Aug. 31/2024):** Terraforming operator Jen Han on Mars! At your service! My good feelings to you my friend.

## Jen Han Eredyon Session – 08-JAN-2025

Hello my dear friend Jen Han,

Once again circumstances on Terra have created a long delay between our exchanges. From Elena's previous message it sounds like you are quite busy performing operations on Tyr. Thank you for your time in addressing these questions as I know you must be extremely occupied with your starmaker tasks at hand.

JH 08/01/2025: Hello my dear friend Dan, greetings to you and your lady and household of other sentient beings. I have been occupied with my work here at Aries Prime Station. It is from here that we centralize all operations of planetary engineering, or terraforming as you may call it. I always have time for you. We have been very busy here, if I may say so, with the rush to prepare for the arrival of new colonies from Terra in the next two years. We must prepare biodomes and facilities with organic, fertilized soil so that they can settle immediately and be autonomous.

### 1) Higher voltage to torsion field coils

Regarding increasing the output of the Phryll Generator with the double coils, we will take your advice to "*chose the device that allows greater capacity for voltage*".

Therefore our engineer Kent said we will increase the voltage to the torsion field coils from 100 to 300 volts. As we increase the level of voltage we must decrease the time duration of the pulse. Is our understanding thus correct that the highest voltage with extremely narrow pulses is what is desirable?

JH 08/01/2025: *(he takes a moment to remember exactly about the history of the experiment)* Do not decrease the impulse time too much. Narrow pulses as you increase the voltage. Soon we will be able to release more information about the production of Phryll adapted to larger devices, that you can power a complete habitat. We have been waiting for specific changes to occur on Terra's politic scene.

## Plant growth experiment results

As you can see in the below controlled plant experiment using mung bean sprouts with the Phryll Generator coils powered at 100 volts with 300 nanosecond pulses the Phryll generation had no effect on the plant growth. Thus confirming Oona's initial report of a "feeble" level of Phryll output.



JH 08/01/2025: Yes, the Phryll output must have been too low in intensity. Interesting how planetary magnetic fields affect torsional fields. On Terra, it seems you need a stronger pulse. On our worlds, space stations, ships, we use magnets. I cannot give you the correct equation to create a torsion field engine because it would put you in danger. We must wait a while before we can discuss this in complete safety. A little while, my friend, a little while. For now, the Phryll generator is powered by electricity from your habitat supply. I would suggest increasing the input power. Gradually.

## 2) Regarding water nearby to make Phryll generators more efficient.

Reference:

Jen Han: *"This is stable and greatly efficient because of the lake. The water. Phryll generators are always near water."*

Note in the above plant experiment photos that I placed a large bowl of water next to the Phryll generator based on this statement. Is this another factor when using a small Phryll generator to have a body of water nearby? What is the mechanism of how the water increases efficiency?

JH 08/01/2025: Water has a vortical effect. When it receives Phryll, it amplifies it because water is a transponder fluid. If a source of Phryll is activated near water, water will increase the production. In Atlaa, the generators were on a peninsula. On my home planet, where my family lives, the valley generator is by a lake, at the far end, on a hill. The structure of the water is rearranged when it comes in contact with Phryll.

### 3) The presence of the consciousness of a sentient being to activate the eye of the crystal

Reference:

Jen Han: *“The activation of Phryll by the generation of pump gravity waves or scalar as you name them, creates a torsion field when the crystal’s eye opens. You need a pulse, but also consciousness. No machine can do it if there is no consciousness nearby. That is why we always have sentient beings to attend the generators. Their presence gives the last element needed. The operator must have a good symbiotic relationship with the crystal. In more scientific terms: an interface. A mind interface.”*

Besides being in physical proximity to the Phryll generator crystal, does the operator need to do any preparation to mind interface with the crystal? Once the eye is activated, does it require continual presence by the operator to sustain operation?

JH 08/01/2025 The Operator is needed to be in attendance at the Generator because once the Mind Interface has occurred, the Operator's mind brings the Central Crystal into balance. The operator doesn't have to be present all the time, but about once a day. A large or powerful crystal can have many attendants whose minds are interfaced with it, then they can take relays. The attendants can also gather around the crystal for special events and activate a greater production of Phryll. On different worlds, a circle of attendants interfaced with a central crystal can create a powerful vortex, even what you call a stargate, or even communicate to the other side of the universe. Remember, such a crystal was found by your friend Dr. Brown.

#### **Note 29-JAN 2025:**

In this next brief session Elena connected with her device to Jen Han on Mars in the middle of him having a lunch in the company of an Alpha Centaurian girl, a cute blondie named Cena. She was connected telepathically to him, listening to their conversation as he allowed her so. Probably to impress her. He was also a bit distracted Elena said.

# Jen Han Eredyon Session – 29-JAN-2025

## 1) Frequency key shot at compression node to assist Phryll generation

Previously in discussing the Phryll generators on your planet you said..

*“It is activated by sound. Well to be more precise: by a frequency key shot at its compression node.”*

I am wondering if our “feeble” output is missing this element and we should incorporate it to make a difference? If so would you recommend to periodically send the 1496 Hz sound waves into the area of the eye as you recommended previously?

JH 29/01/2025: A frequency key is a structure based on geometric patterns. These patterns are created by the nature of the vibration of the frequency impulse. These geometric patterns created by a frequency in the ether are invisible to your eyes unless they are transmitted through water, for example. To crystallize or stabilize and store these patterns, we create holograms with them. These holograms are activated when they receive the appropriate frequency impulse, and are quite powerful in their concentration. These are emitted into a crystal for whatever use you wish, but frequency keys are most often used to lock or unlock elements, from the smallest to the largest stargates. So yes, to get back to your question. I doubt you have that kind of technology in your home. That is to make frequency keys. But you can send a frequency pulse to the crystal vortex. Yes, for the 1496 Hz. Do it at a fast rate.

## 2) Polarity of electron flow through the torsion field coils

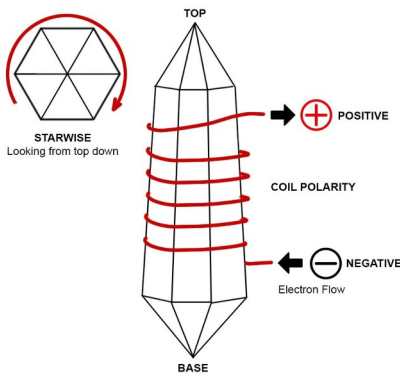

A) Reconfirming for our science team the “Starwise” coil winding direction around the crystal

JH 29/01/2025: Confirming.

B) Whether the polarity of the electron flow direction should enter at the bottom of the coil or the top when powering the coils if this is a consideration? (single coil shown only as illustration)

JH 29/01/2025: At the bottom of the coil.

C) Would this polarity of electron flow be the same for the silver and copper torsion field coils?

JH 29/01/2025: Yes this is correct

### 3) Etheric energy conversion into physical reality with the open singularity vortex using 20 Hz compression waves to modify the matrix of reality

Reference

*“The 51.843 angle geometry transponds etheric energy and the 60 angle geometry imprints it into the holographic matrix of the universe. This is a great network. This is how we implement etheric energy into physical reality, and this is how the Liminal Geometric Point of Transfluxation allows the intentions of consciousness to imprint a geometric thought pattern.”*

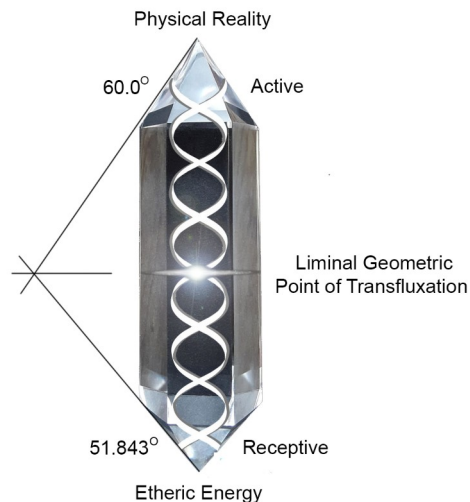

From your description I have designated to call this device a “Reality Transflux Modulator”,

JH 29/01/2025: The name is awesome!

as the intentions of consciousness modulates the point of transfluxation with a geometric thought pattern which is then imprinted to modify the holographic matrix of reality.

JH 29/01/2025: The equivalent of a holographic frequency key, generated by your consciousness (frequency = intention), carried on a geometrical electric pattern (brain compression waves)

As you once stated *“this is like a machine that can create anything”*

JH 29/01/2025: Yes it is.

Could you give an example application of how you or the federation uses this specific technology to ether modify or form physical structures from the etheric energy?

JH 29/01/2025: We use them to control time, to manifest the effects of a dynamic in motion. Quite complex to explain, but we also use these transflux modulators to generate etheric energy, we use that to power certain spacecraft, the spherical ones in general. We also have some in our house to enhance the holographic configuration of the day ahead. It is very difficult to do. But the way I know best is terraforming. We use this type of technology to create etheric spheres around dead planets so that sentient life can begin. We can also control the weather with it, but implemented on other devices that are different.

#### 4) The Time Factor

JH 29/01/2025: I was just talking about time engineering!

Reference:

Jen Han: “When you send out a hologram out there into reality, the hologram becomes reality sooner or later, carried with the tides of the universe. Time is the factor that will synchronize your holographic project into the physical matrix of Creation.”

JH 29/01/2025: Yes. I said that.

Without the aid of technology, as your consciousness creates a hologram with your mind, it imprints it into the grid of the universe through your pineal gland’s vortex connection to Source, and in time this imprint will take form in your reality if I am understanding correctly. It appears that a major factor in the element of time this takes to take effect is your level of belief and confidence in your ability to create.

JH 29/01/2025: Also, but time is foremost a complex, multilevel equation.

With the aid of crystal technology, since all matter is created at the highest density first before fractalizing into matter, a projected hologram imprint through the crystal’s open singularity vortex that is a quantum bridge directly to Source through the Void imprints into the grid of the universe that is not subject to the factor of time. Therefore when the mind effectively interfaces with the open vortex of the crystal the formation into matter should be instantaneous if I am understanding correctly?

JH 29/01/2025: Yes, for the simple reason that consciousness, and therefore thought, is not connected to the equation of linear time.

#### 5) The 20 Hz pulse frequency tolerance

I know you said when using frequencies to be accurate. I’ve identified an affordable frequency pulse generation source for the public, but it’s frequency was measured at 19.8 Hz instead of 20 Hz. Would this slight frequency difference supplied to the silver electrodes be less effective than at 20 Hz, or would this be insignificant difference and still open the vortex singularity in the same way?

JH 29/01/2025: I think it will still trigger the vortex. You can never get the precise fractal frequency, it is impossible. Elena asks me what a fractal frequency is. Well, it is the nature of frequency itself: a frequency is characterized by a series of numbers. Know that this number fractals to infinity. You can approach the absolute value of a frequency, but you can never reach it. At some point it is close enough to be effective, though it will never be exact. This is a form of mathematics you may not be used to. When you work with the geometric dimensionality of frequencies, you can notice these variations visually.

## Jen Han Eredyon Session – 06-FEB-2025

### 1) An experiment to quantify the modulating of etheric energy into physical form

Elena and I both have our Reality Transflux Modulators set up so that the crystal is loosely supported between two plastic discs to allow it to oscillate freely and our signal generators supply the 20 Hz pulse signal to the pure silver electrodes across the eye of the crystal.

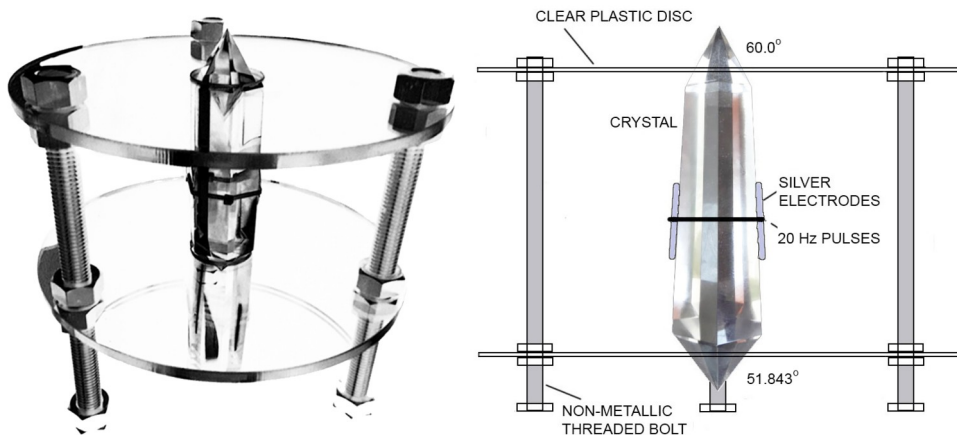

I was wondering if there a way to quantify the etheric energy being modulated with the intentions of consciousness that is being written into the tetrahedral fractal holographic matrix from the 60 degree sender end of the crystal that reshapes the holographic grid of reality?

JH 06/Feb/2025: You do not have the technology to quantify an etheric field, but what you can do is test it with the consciousness interface. I explain. Right after you turn on your modulator, you can interface your consciousness with the eye of the crystal, which is triggered by the pulsed compression wave. You will get a sense of intensity. As the seconds pass, you will feel a slight, slow increase in intensity. You may also feel a tingling sensation in your chest. If your eyes are closed, you may see light, white or blue. You may also feel a different sensation. Also, an etheric field ionizes the particles of the atmosphere, and if it is strong enough, you can see a slight glow. If you get some technology to quantify the ionization, similar to a plasma detector, you can say that you have measured the light generated by the activation of the crystal by a pulse compression wave. Measure the "light" it produces, which is actually plasma. It may not be visible to the naked eye, but your instruments will detect it.

Could some type of reactive material or substance suspended above the 60 degree termination area react to change or visually take form as modulated by the projected geometric pattern of thought into the eye of the crystal? Some examples such as water, light, plasma or even a quartz sphere to open it's central vortex to form a visual reaction to this modulation.

JH 06/Feb/2025: With water you can see changes in the structure. A quartz sphere will show nothing. Coherent light can be disturbed by the interferences generates by the activated crystal.

## 2) Understanding the Fractal Core Formula of frequencies manifested from Source in our universe.

In our particular universe, I understand that the geometrical resonance of the lattice structure of quartz is 4096 Hz which is in synchronized frequency with Source. This frequency is also in fractal resonance with the frequencies of light, water and love.

I am attempting to understand the interrelationships of the fractal core formula with the elements of quartz, water, light and love to this fundamental frequency of 4096 Hz which emanates from Source.

Since light is a spectrum of frequencies, is there a single frequency to represent the frequency of light?

Love I understand is a more complex holographic structure. Does it have a fundamental frequency?

You said the frequency of water is 2,450,000,000 Hz (2.45 GHz) and that 4096 Hz is a fractal measurement of water and that the fractal ratio relationship of these two frequencies you said was mathematically expressed as 0.0356521923094988

None of our science team with our math have been able to correlate this fractal ratio between these two frequencies of water and 4096 Hz. Is there a special fractal based mathematics required to see this relationship?

JH 06/Feb/2025: Light has 144 wavelengths. Your naked eye can see only a narrow range, and your instruments can detect only a little more. Only consciousness can grasp and "see" the complete formula of Light. Light is not only an arrangement of particles, it is also emotions, sounds, frequencies. The formula of Light is complex because it involves multiple levels of manifestation. Light has a multidimensional formula. The frequency you have been given is a mathematical fractal of it. Light is creation. Light shapes reality by creating the holographic matrix of the universe. That is why light and love are on the same fractal equation. Light creates, love binds. You will discover soon a new dimension to your mathematical equations.

## 3) Frequency relationship with the tetrahedral forms of the holographic matrix structure

The square root of 4096 is 64, and this you said is related to the 64 tetrahedron grid, saying this is the scale of the building blocks of creation.

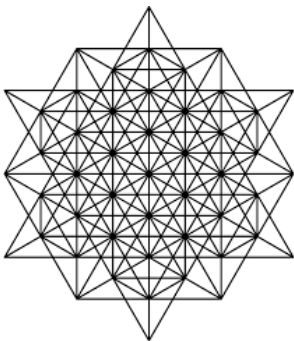

That there is a direct relationship between each tetrahedron form structure and each frequency oscillation cycle. i.e. 64 tetrahedrons and 64 oscillations. So is this how physical structures in the holographic grid of the universe are created in complex tetrahedral structures from the ethers that have a directly related frequency resonance?

JH 06/Feb/2025: Physical structures are first created holographically if part of a terraforming program. In the natural organic evolution of Creation, everything unfolds from geometrical frequency arrangements. Each frequency shapes matter, and matter emits frequencies from their geometrical structure. What Creator gives; creation gives back.

#### 4) The Planck's constant of energy in relation to various densities in our universe

Chris had a question regarding the Planck's constant, symbolized as "h", is a fundamental universal constant that defines the quantum nature of energy and relates the energy of a photon to its frequency. If our universe has 12 densities with the 13th being Source, is there one "h" constant per density? or less, i.e. one "h" constant per materialized density? How many "h" constants for our universe?

JH 06/Feb/2025: I understand. The frequency of matter is a variable and the constant ratio between energy and light evolves differently regarding the density. "h" is a variable because of speed. Speed multiplied by light equals the root of energy released by the photon. A photon doesn't release energy when not submitted to the ether. Light travels at different speeds regarding gravity. So does the mathematical value of time. Gravity has to do with the ether. You understand? Ether is everything. Ether is not void. The only void that exists is the Great Void between the universes. Within the universes, there is no such thing as void. Because of the gravity forces and the particles, all given by the ether. We are forbidden to give you direct formulas of equations, but we can guide you towards where you need to research. Light-Time-Gravity.

#### 5) The periodic table of elements related to tetrahedral formations and frequencies and the structure of the elements of matter

Would you say that our table of elements are then actually based on these tetrahedral formations and their corresponding frequencies?

The image shows the IUPAC Periodic Table of the Elements. Several elements are highlighted with red boxes and pink circles. The highlighted elements are: Be, B, C, N, O, F, Ne, Al, Si, P, S, Cl, Ar, Ba, Hf, Ta, W, Re, Os, Ir, Pt, Au, Hg, Tl, Pb, Bi, Po, At, Rn, Gd, Tb, Dy, Ho, Er, Tm, Yb, Lu, U, Np, Pu, Am, Cm, Bk, Cf, Es, Fm, Md, No, and Lr.

JH 06/Feb/2025: It is interesting how you classify your elements. There are so many more you haven't discovered yet. I couldn't answer that question clearly, but I do know that the structure of each element is based on a geometry that emits frequency forms. Its frequency signature, so to speak. I think I can answer your question with a yes.

## 6) The principles of the replicators

I've heard the stories from those who have been onboard the Excelsior battle station XL6 and have used the food replicators to create various food out of the ethers. Can you elaborate how these machines are able to bring physical matter into form?

JH 06/Feb/2025: Oh, that is quite simple. There are two main types of replicators. Some have a recycling container at the back of the replicator. Most replicators have this built in. When you enter the holographic equation of a new object, the device rearranges atomic particles from the old matter to form new bonds and creates the desired object. It is atomic recycling, with a twist. On the second type of replicators, there are cylinders of raw atomic matter at the back or underneath that are to be used. These cylinders are highly ionized to aid in the process of forming new atomic arrangements. Now the standard on our ships is the second type, but in basic households it's the first type, which is cheaper to get and run because you don't have to purchase the cylinders.

Thank you my dear friend for taking your time to answer these rudimentary science questions. Things appear to be moving more rapidly on Terra and I look forward to when the Prime Directive restrictions have lifted and we may one day meet face to face my dear friend.

Your student and friend on Terra, Dan

JH 06/Feb/2025: I look for that day too my dear friend!

# Jen Han Eredyon Session – 01-MAY-2025

Hello Jen Han my dear friend,

Grateful for all of the information you have shared. Elena and I will be doing a class for the Terrans on “Crystal Science” to teach a few basics of what we have learned thus far from you. There are just a few questions that I am curious about, that I would love to hear your insights to help expand our understanding of these sciences.

## 1) Relationship of frequency cycles and tetrahedral forms

For our Crystal Science class, there is just one item that I am not certain I've interpreted correctly from your answer, so I would like to verify this with you beforehand my dear friend.

### Our previous communication:

Dan: So the 4096 Hz frequency is fundamental to everything in our universe as it is a fractal or harmonic integral of it. The square root of 4096 is 64, is this related to the 64 tetrahedron grid?

Jen Han: This is correct.

Dan: So if the 4096 Hz frequency has as it's square root of 64 (somewhat like a fractal expression of the 4096 Hz) and this 64 number is related to the tetrahedral 64 grid structure, is there a relationship between each tetrahedron form structure and each frequency oscillation cycle?

Jen Han: There is.

### My question is:

It is understood that the universe is made up entirely of varying complex fractal tetrahedral structures, each emanating a frequency based entirely upon it's tetrahedral structure in the ethers of our world.

You stated that there is a relationship between each tetrahedron form structure and each frequency oscillation cycle. For example, would it be correct that 64 tetrahedron forms creates 64 frequency oscillations or 64 Hz, or for example 512 tetrahedron forms creates 512 Hz frequency resonance etc?

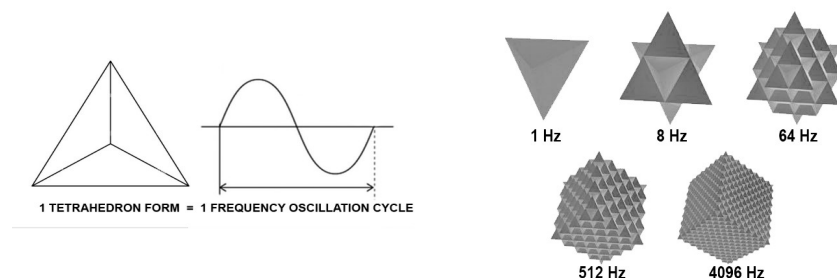

The structures that give the solid appearance of our physical world, must be made up of a great many tetrahedrons in fractal arrangements that universally form every form we know. So, if there is a direct relationship of 1 tetrahedron for one cycle or 1 Hz, then 1 trillion tetrahedron forms would resonate at 1 trillion Hz or 1 terahertz frequency. Is this form and frequency relationship understanding correct?

**Elena writes May 01 2025:**

Hi my dear friend, Jen Han responded I had a communication with him right now. He was finishing a work on holographic devices and was about to catch a shuttle for Alpha Centauri after, spending two days there. He said it was not for work so I asked him if there was a girl involved. He said yes, but not the one that was with him in the cafeteria on Aries prime, last time. It's a new one. Jen Han is very discrete on his personal life so I respect that and didn't ask more questions. I guess the Alpha Centaurian girls are rather cute lol.

**Jen Han May 01 2025:** There is an infinity of tetrahedral structures, just as the equation of the universe is infinite, it expands infinitely toward a tangent that never touches perfection. As you may know, perfection is death. Dynamics stop when expansion stops, so the created freezes and evolution ceases. The cosmic equation is infinite because creation is in constant evolution. It relates to frequency. Everything, matter, energy, consciousness, is made of frequency. Every tetrahedral structure generates a frequency equal to its structural value. Yes, you are right when you say that form and frequency are related. They are. Every organism or planet is made up of a multitude of tetrahedral keys. You can understand that every thing in the infinite multiverse has its own song.

**2) Regarding the star tetrahedral geometrical structure within planetary bodies**

It has been noted that star tetrahedral measurements of energy points on planetary and solar spheres include this 19.5 (more precisely 19.47) degree energy point which demonstrates it's presence on nearly every body in our Solar System.

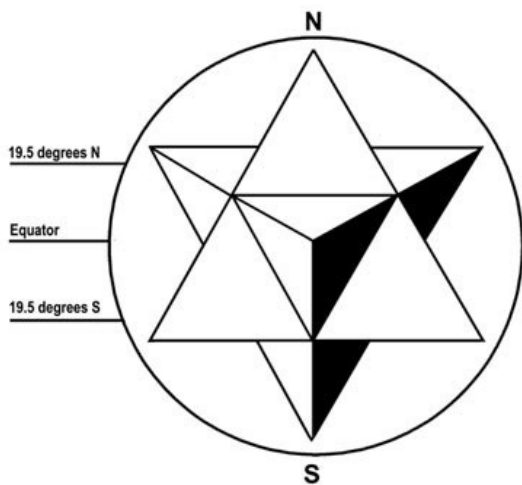

- Sun (sunspot patterns that do not go above 19.5 degrees north or south),
- Mars (the Olympus Mons shield volcano at 19.5)
- Venus (two volcanoes at roughly 19.5)
- Earth (the Hawaiian Islands at 19.5)
- Jupiter (the Great Red Spot at 19.5)
- Neptune (the Great Dark Spot at 19.5)

Could you give some insight into the significance and function of this star tetrahedral formation in all the planetary bodies including our star?

**Jen Han May 01 2025:** The formation of star tetrahedrons in all planetary bodies, including stars, is a component of what we call the etheric grid. What we call the etheric grid is not a spiritual aspect of a planet, remember that, for I know that the word "etheric" has been used on your planet to describe spiritual interaction. Etheric means "of the ether". The ether is a potent super-medium that when activated by frequency, whatever the generator of that frequency pulse is, the particles that make it up and are in a latent state move according to the longitudinal pulse that traverses the ether. Gravity is one of them, and so is dynamic form geometry. The etheric structure of any planetary body is a tetrahedral structure that pulsates constantly. There is a core, a simple basic structure that we call the heart, and this multiplies into a complex geometric grid network of nodes and power points that we call spikes.

### 3) The planetary grid formed by icosahedron and dodecahedron geometries

Researchers have noted a geometrical grid whose nodal points align with areas on our planet of ancient cultures of renown, such as the pyramids in Giza, and other significant areas in the UK, the Atlantic and the Pacific oceans etc.

Icosahedron and dodecahedron grids on planet Terra

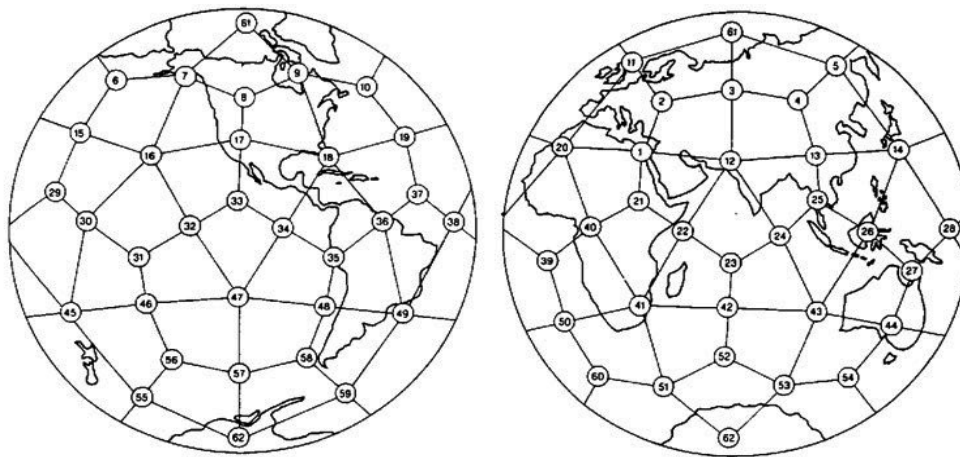

These geometries are known as what we call "Platonic solids"



They can nest within each other, where the nodal points of one geometry will connect within the other



It is understood that all planetary spheres are living beings, and have a different energetic form from humans, and could be related to the various frequency levels within it's body.

Are these various energy grids related to our planet's various energy bodies, such as the chakra vortexes in the human body?

Are the intersections or nodal points that connect one geometry frequency to the next, forming a vortex at these nodal points that allows the frequency shift from one geometry to the next?

Are these nodal points that form these vortexes, the reason why ancient structures are built in alignment with these energies in order to couple and affect the entire geometry of the energetic planetary body?

**Jen Han May 01 2025:** There is an established relationship between a planetary grid and the biofield of a biological body that is indigenous to that planet. When a body avatar is made out of the etheric grid of the planet, but also its waters, its minerals, and its air, it is in very close synchronization with the breathing of the etheric grid of the planet. For everything that is connected by the same elements pulsates at the same rate. The heartbeat of all creatures is in fractal co-relationship with the natural planetary pulse.

Yes, the nodal points that connect one geometry frequency to the next, by forming a vortex at these nodal points, allow the frequency to shift from one geometry to the next.

Quite right my friend, ancient pyramidal structures were built on your planet at nodal points, but not only. The ancient projects followed certain lines of force, especially the ancient magnetic equator. When you establish colonies on a new world, you must begin to use its power grid to power your devices and the new habitats you will build there.

#### 4) The geometrical spacing of planetary orbits in our solar system

An ancient earth astronomer observed the spacing of the six known planets at the time from Mercury out to Saturn were separated by the Platonic solids in the sequence octahedron, icosahedron, dodecahedron, tetrahedron and cube. The Sun was at the center of the six concentric spheres.

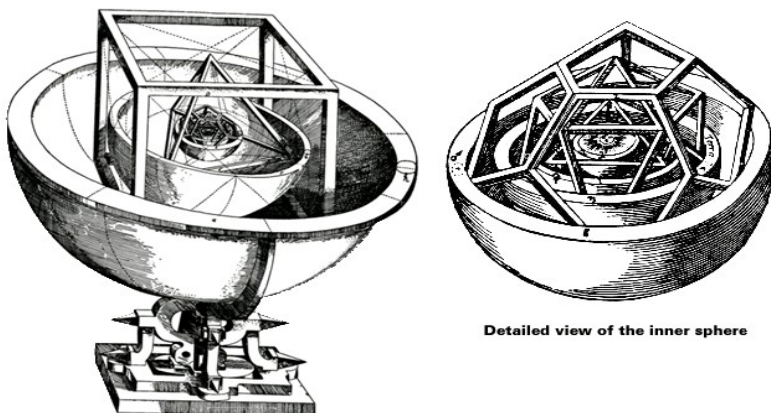

## The related Platonic solids to the planetary orbits of Venus, Earth, Mars, Jupiter and Saturn

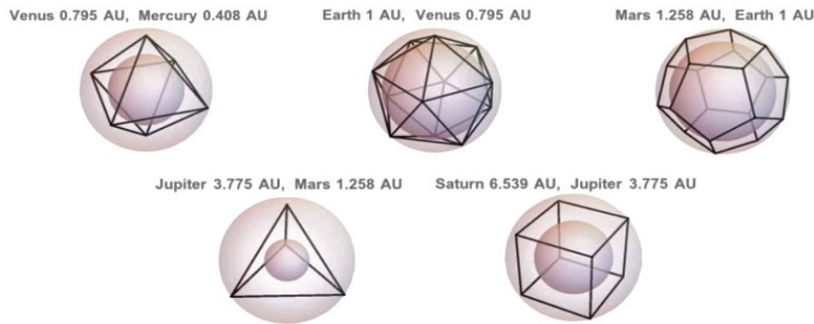

Could you give some insight as to why the spacing of these planetary orbits are related to these Platonic geometries?

Is this geometrical spacing common throughout our galaxy?

You being a star maker, I would like to ask about our star the sun. Is our star like the opposite of a black hole and is it directly connected to the central sun of our galaxy as is all the stars?

If I may, I'm going to slip one more question in from a wonderful new member of our science team in Switzerland, Christopher asks:

“Related to the creation of a large-scale asymmetric singularity. This is in regard to galaxy formation. What happens when two black holes are orbiting and getting close to each other? Is matter getting splashed out of the vacuum due to relativistic effects, where pair formation can't recombine. The pattern that looks a lot like a spiral galaxy.”

**Jen Han May 01 2025:** You will notice that Mars and Earth, Tyr and Terra, have quasi-similar tetrahedral structures. We even called them with nearly similar names. The reason for this is that Tyr and Terra were considered as twin worlds, until Tyr was destroyed by the explosion of Yana, or Maldek as you call it on Terra. Yes, this geometrical spacing is common throughout the infini-verse.

I will answer about the nature of stars when I arrive on Selo, I have a shuttle to catch. I will make communication later. Give my best to the best of men on Earth my friend Dan!

## Jen Han Eredyon Session – 25-MAY-2025

Hello Jen Han my dear friend,

Again, always grateful for your time in helping us Terrans understand these sciences that could be put toward beneficial purposes for all beings on our planet.

Understanding the core fractal frequencies of our universe, as it relates to both quartz and water is an important understanding regarding the 4096 Hz resonance of these elements.

Regarding water, you stated it could be resonated at 4096 Hz to be healthful, so our small science team, which now includes Christopher Cooper, is attempting to utilize this resonance of the water structure which re-tunes it to the universal harmonic frequencies of Source in our particular universe. When this happens, it appears that the water lattice structure goes into a perfectly balanced, geometrical absolute, state of resonance that disallows any dissonant patterns to coexist within this lattice structure. For biological lifeforms to consume, I can see how this can be healthful, but only dealing with purely water alone. This is different, when the water co-exists with other physical contaminants. We are seeking a way to removing these by taking advantage of resonating at 4096 Hz in order to keep the water lattice in a tight geometrically aligned structure which keeps all energetic dissonant elements excluded. While doing this, seeking to find a way to then separate those physical contaminant elements from the resonating water. So we are experimenting, possibly some form of centrifugal extraction of the physical contaminants while the water structure is resonating at 4096 Hz frequency?

*Jen Han was in a large vehicle with another guy, an Alpha Centaurian driving to the nearest base after they gathered data from a sort of metallic tower.*

JH (24 may 2025): Hey my dear friend Dan I salute you. I am currently back on Mars and ready to continue reshaping this planet. This includes collecting measurements of atmospheric pressure, tectonic activity, and gravitational and electromagnetic charge fluctuations. I am well aware of the attacks on Elena. Thor Han briefed me yesterday after I returned from Siluin. Unfortunately, this is a consequence of Elena's forthright actions. From what my brother told me, liars don't appreciate being called out. She is brave. I would do the same. Regarding your question, a greater amount of impulse can be broadcast into the water depending on the cubic volume to be treated. You obtain faster results when the pulse is stronger. More powerful. Regarding your level of technology, the best system you found is the extraction of impurities by centrifuge operation while 4096 Hz is being broadcast into the water. However, I think some scientists on your team are above average and can advance the experiment. The next level is a frequency key, which is above a frequency. Frequency keys are geometrical algorithms embedded in a carrier frequency that reorganizes matter. We encode them in a holographic container stored in a program. You do not have access to that technology yet, but you should research the geometric patterns created by 4096 and find a way to project them simultaneously.

*(I am shown a geometric cymatic figure carved with golden lines on a disk that is placed in a container filled with water.)*

*JH's commentary on what I just saw:* No, that's the simplest way, but not the most efficient. Only a little. What you need to do is broadcast the specific frequency's geometric keys into the water, which will produce quicker results. When the frequency wave hits the water, the water's structure will change due to holographic resonance. We use this technique to open wormholes and stargates from the void when the superfluid is present.

*(I know JH is talking about the "black energy" stargates' fluid).*

You can broadcast only the simple frequency carrier wave. It will work, but it will take more time. You can use crystals or programmed crystals in the water, or you can get the water to spin very fast around these crystals. There are different methods.

Approaching destination, will talk later.

Besides creating a beneficial water cleaning process using frequencies, the main goal is to present scientifically verifiable evidence, which we will present to the world, that would give further credibility to our dear friend Elena, that this information you have graciously shared is scientifically viable.

Our newest science team member Christopher would like to comment:

Dear Jen Han,

it is an honor participate in this dialogue between you, Elena Danaan, Dan Willis, and the science team. I am delighted that you enjoyed receiving the gift of crystal from Terra. It is clear from the communication logs that 4096Hz is a very important frequency key. Inspired by your guidance, I exposed water containing dissolved SiO<sub>2</sub> to 4096Hz sonic waves. I observed bubble formation indicating cavitation and the formation of cloudy white partials in the water. This led me to speculate as to the possible that the solubility of water could change when exposed to the 4096Hz.

I then exposed a small sample of saturated salt water to the 4096Hz for 10 minutes. After exposure sample had high optical clarity. I then had the idea to attempt dissolving more salt in the already saturated water. To my amazement I was able to dissolve considerably more salt in the sample of water. (I am now 2 days into the experiment and am still able to, between exposures dissolve more salt to an already super saturated saltwater solution.

JH (25 05 2025): It makes the water more penetrable, permeable if I may, losing up its atomic structure by activation on a specific frequency. Water doesn't retain salt molecules but breaks them down because water becomes charged as its ions are being vibrated by the frequency impulse traversing it. With salt it is a little particular because it naturally charges the water, especially when ionized. In your experiment dear Christopher, you didn't only expose the water to 4096 but also the salt. There is a more complex inter-reaction.

Regarding Silicon dioxide, it is a component of quartz and highly responsive to 4096 as well. By pulsing certain frequencies through Silica Dioxide dissolved in water, you create Phryll. According to the universal law of dynamics regarding the creation of energy from a dormant medium using gravity waves. It may be through the ether, water or quartz. Through love as well. But this is of a higher level non-related to the experiments you are conducting.

With some other inclusions into the water the results may vary. You shall experiment with biological material such as bacteria, and calculate the pH of water after exposure to 4096. You will need to add a dynamics to the fluid in order to evacuate the biological molecules out of the water. Be aware that this process involves isolating sometimes the harmful elements harvested out, so the experiment when using contaminated material must be pristine safe.

I see three possibilities:

1. The frequency key of 4096Hz changed the physical properties of the water to dissolve significantly more salt than water in its native state, or;

JH (25 05 2025): Yes Christopher, that is correct, this is what I just explained.

2. Perhaps Phryll was generated and stored in the water. Then my intention of dissolving more salt in the water triggered a Phryll enhanced mind-matter interaction such as one can expect from an advanced yogi, or;

JH (25 05 2025): your mind didn't need to interact. In that case of an experiment, remove the consciousness factor. Phryll was created when you experimented with Silica. Because of the scalar wave, the frequency pulse of 4096 broadcast. With salt, you obtained ionized water. In that medium, the particles that are not water are set loose and you can easily isolate them out using dynamics as you broadcast the 4096 frequency through the water. 4096 breaks bonds between mediums such as quartz, water, human heart field, and all inclusions that are not it. Programmings is another example. You can deprogram water with 4096 in the same way you deprogram quartz. You understand?

3. I am completely deluding myself and If I run the experiment 100 times this observation will fall below statistical significance.

JH (25 05 2025): I don't think so. You will get some results. Why 100 times? I suppose it is the standard procedure on Terra for scientific validation.

I would love your insights regarding Phryll, intention and the possibility of Phryll induced mind-matter enhancement.

JH (25 05 2025): Consciousness is not the carrier; it is the information. The carrier is the electrical brainwaves of the human brain that imprint the physical plane of existence you belong to for this incarnation on Terra. Electric brainwaves carry the thought, and the thought encodes brainwaves with a specific frequency key. I was mentioning frequency keys yesterday. This creates Phryll when broadcast through quartz. It is a higher language used by some cultures also, communicating by sending encoded bundles of information, encrypted as frequency keys, on a carrier frequency wave. Brainwaves in this case. Consciousness + carrier impulse through quartz = physical manifestation of the original thought into physicality. Quartz transponds densities of physicality, hence also thoughts into physicality of existence.

Same as ether, when pump waves are broadcast into quartz, it produces Phryll. Thoughts do, of course, for they are also gravity waves, but the production of Phryll will be barely noticeable by your instruments. What you need for creating Phryll from quartz is either mechanical pump waves or frequency, to activate a still state into energy.

Water will not produce Phryll, as it has not the arranged tetrahedral lattice structure of quartz.

But keep in mind as well, I like to put it like this, that consciousness via carrier brainwaves can change the structure of water. This is called programming.

Remember, your brain is made of a significant percentage of water.

I wish you good success in your endeavors, Christopher. And thank you again, for the beautiful, connected crystal.

My Very Best Regards,  
Christopher Cooper

**Dan here:**

Just for clarification my dear friend, on the last communication I asked if there a relationship between each tetrahedron form structure and each frequency oscillation cycle?

You stated:

Jen Han: There is.

**My question is:**

Is there direct relationship of 1 tetrahedron for one cycle or 1 Hz? For example if there was a structure containing 1 trillion tetrahedron forms would it resonate at 1 trillion Hz (1 terahertz) frequency? Is this form and frequency relationship understanding correct, or is it more complex than that?

JH (25 05 2025):

The frequency rate is generated by the shape and structure of the tetrahedral arrangement, not by the number of tetrahedra in the arrangement. When a crystal is cut from its matrix, both the matrix and the newly cut quartz carry the same tetrahedral frequency. However, when the arrangement varies in shape, the frequency varies. The important factor is not the number of tetrahedrons, but the physical shape they form when assembled. A crystal has the universal quartz frequency, but the frequency it emits varies slightly based on its shape. The shapes of their physical structures emit frequencies. Examples include spheres, pyramids, wands, and complex tetrahedral structures with lattices that can be arranged in infinite ways.

## Jen Han Eredyon Session – 25-JUN-2025

Dear Jen Han, you being a wonderful star maker, I would like to ask about our star the sun. Is our star like the opposite of a black hole and is it directly connected the central sun of our galaxy as is all the stars? Would love to hear your insights on what exactly stars are that exist in the ethers of our dimensional universe.

**JH June 25 2025:** So you want to know how to make stars. Stars are what you may call “White Holes”. They expand in consciousness and energy the consciousness and energy from Creator Source, radiating from the One Singularity. The One Singularity is not a White Hole, for it is the original singularity of everything. It doesn’t exist in a particular space and time, it is omnipresent, eternal and omnipotent. The stars are ignited plasma gases bound by a gravitational dynamics. We can create stars if we have at disposal a great amount of dormant gasses such as in the Nebulas or proto clouds. By generating a circular impulse wave we trap the gas and activate the particles of ether in it. We create a distortion magnetic field that will ignite the gas to become plasma. When the building up of the activated plasma reaches up to a certain mass, a mass that is spherical and isolated from the outside space medium, gravity bounces towards the exact center and creates an opening. This is a singularity that is not hovering in the particles of plasma but instead, opens a hole in the fabric of space time that connects directly to the nearest “white hole source” that binds it by gravity: which is the galactic center. This process may be generated artificially, or the product of natural formation. Galaxies have a gravitational field that entraps all stars to the center. The galactic centers may be single, double, triple or quadruple. They connect to the universe center, which connect in turn to the One Singularity.

Are the 12 densities of this particular universe that are emanating from Source each resonant with one of the octave multiples that relate to the tetrahedral cuboctahedron geometry expanding from...  
1 - 8 - 64 - 512 - 4096 – 32,768 – 262,144 – 2,097,152 – 16,777,216 – 134,217,728 – etc. ?

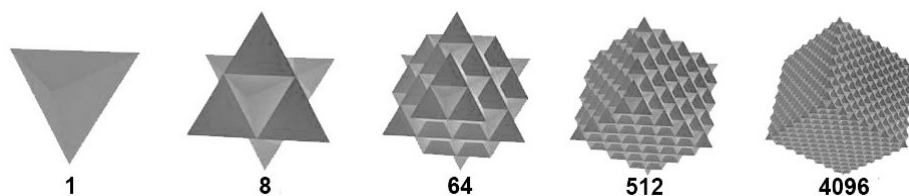

**JH June 25 2025:** That is correct

The following 4 questions are from our science team member Christopher, who wished to express his gratitude to you for your previous answers.

**JH June 25 2025:** Christopher’s name is known by my brother because some scientists he worked with on his station participated in an exchange program with him I think.

Related to the creation of a large-scale asymmetric singularity. This is in regard to galaxy formation. What happens when two black holes are orbiting and getting close to each other? Is matter getting splashed out of the vacuum due to relativistic effects, where pair formation can't recombine. The pattern that looks a lot like a spiral galaxy.

**JH June 25 2025:** I need to explain the nature of black holes. What you call black holes do not swallow gravity waves to transport them elsewhere. Rather, they bounce them back from the node, or singularity. A node or singularity radiates gravity waves back outwards in all directions. A node or singularity is like a heartbeat: constantly taking in and giving back. Listen to your heartbeat: it is a double pulse, in and out. This is universal and occurs at all levels. One day, you will discover that black holes have a double pulse. Your heart rate resonates with your planet's heartbeat. When you leave your planet, you lose the harmonic pulse resonance.

Each singularity node is connected to the nearest super singularity. The correct term for a black hole is a "vortex." When two vortices collide, they can merge to form a more powerful vortex. Sometimes, however, they interlink their gravitational horizons to create mass dynamics. Galaxies form from the balanced gravitational dynamics of two, three, or four vortices. The most common natural occurrence is a double-center galaxy. Balance is achieved when the event horizons are stable. This creates a powerful gravitic pulse that energizes the ether, creating plasma. Gravity pulse waves—or gravitational scalar waves, if you prefer—stimulate the ether and can create plasma when they are within a certain power range. Due to the intense gravitic field in plasma, stars are born, as I explained earlier.

Here is how creation is structured regarding the transfer of Source energy through gravitational pulse:

- Creatures' hearts and moons are entangled to the pulse of their planet.
- The planet's pulse is entangled to the star.
- The star's pulse is entangled to the galactic center
- The galactic center is entangled to the universe's center.
- The universe's center is entangled to the One Singularity. Creator Source.

Heart beats are gravity generators.

The standard model predicts more solar neutrino than can be observed. This is known as the Solar neutrino problem. The recent solution to this problem was proposed by Terran scientists regarding a so-called neutrino oscillation.

A simple solution to the solar neutrino problem can be arrived at if one takes the view that the sun is a hyperspace tubular formation intersecting with our 3-dimensional universe. What are your thoughts?

**JH June 25 2025:** Stars are not gateways to other universes, although this rare occurrence may exist. However, stars radiate spherically into their physical plane as well as towards the nearest super singularity they are entangled to by gravity: the galactic center. Similarly, the particles radiated by the galactic centers also radiate towards their nearest super singularity there are entangled to: the universal singularity or node. The center of the bubble if you will, considering universes in your mind as bubble which is the nearest description.

Here is a better way of saying it: All these gravity waves emitted through the pathways living creature>> planet>>star>>galactic centers>>universal seed>>Creator Source... are bounced back by Creator Source in the reverse direction: to universal seed to galactic centers and so on. This is the heartbeat of Creator. Love, is gravity.

Room temperature nuclear fusion ( $D = H_2$  converted to  $He_4$ ) was discovered, but no group has ever been able to uncover the fundamental mechanism. My research has uncovered the fact that nano-quartz crystals are involved in every well documented successful cold fusion experiment.

**JH June 25 2025:** That is the question that requires my brother to decide if I am allowed to give you this information.

Is it possible to generate a gravitational scale wave in the 12th to 13th octave above 4096Hz and then be heterodyned with an electromagnetic field (at the same frequency) in the presence of Deuterium molecules and have results in thousands of small nuclear energy transitions or perturbations?

**JH June 25 2025:** Unofficially, I believe you could.

If so, then one would observe a 'slow' and safe release of gravitational wave energy that could be released and absorbed by the nano quartz crystal (phonon conversion)?

**JH June 25 2025:** That is correct

I am currently working on obtaining all the equipment needed to start a lab automation testing program to discover quartz crystal frequency keys (FK) and FK combinations. In so doing I am hoping to discover how you manage to fold 3-dimensional electro-gravitational field geometries into higher dimensional field configurations.

Other than measuring the vibrational spectra of the quartz when stimulated with the frequency keys, what other methods of measurement would you recommend for the observation of spacetime effects in or around the quartz crystal?

**JH June 25 2025:** I cannot provide this measurement technology to you, You cannot fold 3-dimensional electro-gravitational field geometries into a higher dimensional field configuration; you need to upgrade its geometry. This is done with sound frequencies.

### **What aspect in the healing procedure is primarily operating when the vortex eye is open?**

There have been expressed various understandings of why, when the eye of the crystal is open that a dissonant pattern in the body is transformed into a resonant pattern or healed, that I would like to get further clarification on my friend. In reviewing what we have learned from both you and Oona...

#### **In the healing procedure that you graciously shared with us:**

After clearing the crystal, to visualize the wounded area into your pineal vortex or mind's eye and recreate it to be a holographic re-paired version, then project that version in sync together with your breath pulse and a physical finger squeeze to momentarily open the crystal's vortex eye upon each piezoelectric pressure squeeze and imprint that version into the temporarily opened vortex. This is then repeated regularly, while pointing the 60 degree angle at the wounded area and rotating it clockwise to cast the re-paired version into your morphogenetic field. The crystal being the bridge between your imprinted re-paired version in your mind's eye and the morphogenetic field of your physical body.

#### **When I shared with you Marcel Vogel's healing procedure:**

You said "his own consciousness was bridging the frequency of the altered bodies to Source"

#### **In the healing procedure that Oona also shared with us:**

Oona stated that the crystal is a bridge to Source, which bridges your consciousness to the disharmonious area through Source consciousness, whose nature is to re-harmonize and repair the wounded area. To project your holographic vision of the repair into the crystal's vortex eye, which is connected to Source and will bridge the creative frequency of Source in the holographic vision you imprinted in the crystal to the target to be healed. Oona also recommends as you do, to rotate over the target area with the crystal or to ether touch the area with the crystal's tip.

[JH June 25 2025: Alteans have their own ways of explaining in deeper manners the same science of the universe.](#)

#### **Oona also stated that quartz is a transponder in the lattice of time:**

That it repairs a wound by transponding through the lattice of time within the crystal with the vibratory key of a previous state in the lattice of time before the wound occurred by reorganizing dissonance with this previous resonant template.

My question regarding all of the above is, is the effectiveness dependent upon the ability to clearly recreate an accurate re-paired holographic version in our mind's eye vortex, which is a skill that Terrans are still yet developing, or is it based simply on our mere intention to bridge the re-harmonizing frequency keys from Source, which is at a level of perfection, which has been directed to flow through the crystal upon each piezoelectric finger squeeze which temporarily opens the vortex eye bridging to Source and then travels out the 60 degree sending end, directed by consciousness to restructure the dissonant holographic pattern with a resonant one?

[JH June 25 2025: As I stated before the previous version of our conversation was stolen, It relies on both. You cannot imprint into the dissonant tissue a perfect holographic construct if the connection to the eye of the vortex is not perfectly aligned. You cannot either heal a tissue when you have a perfect entanglement consciousness/quartz but your holographic construct is deficient.](#)

Is the crystal's open vortex that bridges to Source, accessing through the crystal's lattice of time to resonate a previous template that was the most resonate across the entire spectrum of time, and because the universe tends toward perfection, this previous template that was the most resonant, would then tend to predominate, and therefore only that pattern's vibratory key would be imprinted over the dissonant template pattern, thus healing it?

**JH June 25 2025:** Correct, but not absolute. In truth you can use technology to attune to a chosen version in time. We have devices in our medical technologies that can seek back in time the nearest perfectly resonant pattern version, it can be done automatically or manually if we are working on a specific project.

### **Temporary finger pressure versus technology electronic pulses for effectiveness**

It's probably best for most Terrans to simply use their fingers to squeeze in the area of the crystal's eye for a more organic human body and soul to crystal body connection in sync with conscious visualization and breath pulse, as you stated

“If coupled with a conscious visualization that your mind sends electrical impulses through your body, through your fingertips, the pressure needs not to be very strong.”

In our earlier correspondence when I asked the following question you stated that the “**technology helps greatly**”

I asked this question:

Compared to using a Vogel crystal with just our fingers and finding a rhythm to synchronize with breath. Is using the “metallic” 20 electronic pulses per second considerably more effective at opening the singularity vortex within the crystal?

You responded and said the following:

“I will tell you this: you need this technology at this point in time, because it is more effective than what you bodies are, in average, able to do. But please know this: in a greater knowledge, you do not need this technology because your bodies are purveyed with natural abilities that can do that. You can literally project an electric field through the ether, with the simple power of your mind. Please make sure to tell Terrans to whom you will show this simple technology, that it works as well without this technology, as we spoke before, using their consciousness carried by the breath, and the pulse of their fingers. Of course, technology helps greatly.”

When using electronic pulse technology the crystal sits in a support with electronic pulses across the eye to keep the vortex continuously open, but since the body can not touch the crystal because as you said “your own body electricity will create a dissonance with the metallic wired pulse”.

**JH June 25 2025:** when using metallic pulse simulator, you must not forget to couple with consciousness: projecting your holographic thought towards the eye of the crystal.

Instead of the crystal sitting stationary in a support stand wired for electronic pulse, would it be more effective than using finger pressure to be able to hold and direct the 60 degree sending end into the target area without physically touching the crystal using the electronic pulse with a battery powered pulse generator collar around the eye of the crystal, where only the two silver electrodes are in physical contact with the crystal, but the insulated collar can be hand held and directed at the target area while pushing a button that turns on the 20 Hz pulse generator?



Is the constructing of such an apparatus to direct the 60 degree sending end, while keeping the vortex eye open, worth pursuing to take advantage of using the technology versus momentarily opening the vortex with finger pressure, because as you said, technology helps greatly?

**JH June 25 2025:** Alright, I remember this question. When holding in your hand the crystal while performing this operation, it is best to point the 60 degree end towards the target. When using technology, it is possible to create a quantum transfer to the target, without having to move the crystal. I would recommend, concerning healing and in the actual capacity of your technologies, to rather use the human body, human mind and human consciousness to perform a crystal healing, You will get better and direct results. Additionally, you will develop your own abilities and discover that you are able to do much more.

### **The mechanism of rotational dials tuning resonance the holographic field with consciousness**



There have been throughout our planet's history a number of consciousness assisted instruments consisting of various configurations of rotational dials, of which the operator would rotate these dials to a point of resonance with a holographic sample of the target or individual that was being attuned to by using a sample witness such as a drop of blood, hair sample or fingernail clipping etc. This would act as a DNA fractal holographic representative of the whole of the target individual to form a resonant link, of which any physical aspect or part of that individual could be attuned to.

Such an instrument I worked on with my friend Marcel Vogel, that could capture on a photographic plate the holographic image being projected that was attuned to through resonance by the rotation of these dials. This particular instrument had the additional ability to also tune with a time spiral through the holographic field of time to see various stages of the target attuned to through time.

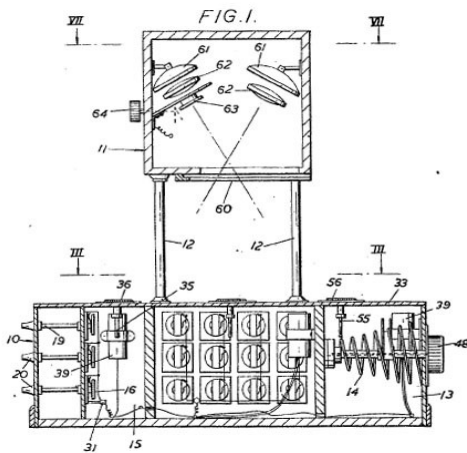

The rotational dials internal connections and photographs tuning through the vector of time



My question regarding this is, since various creators of these instruments, that all use these rotational dials in many variations to rotate to a point of holographic resonance, this resonance is usually determined by the operator through the use of a pendulum or rubbing a stick pad. Is the common denominator of how this functions based on the instrument's creator belief that has, you could say formed an "agreed upon reality" consciousness matrix that has setup rules in their mind of how the device it is supposed to function? I say this because all these instruments vary considerably with their varying number of dials in their cataloged dial settings of resonance. Note that other users, other than the creator of the device, have adopted this set of rules which also works for them.

I know this is akin to “dowsing” or feedback from the subconscious mind using these rotational dials as somewhat of a tuning focus for the mind to form a resonant link.

Nevertheless this device did function, as thousands of photos were produced by this instrument which I worked on with my friend Marcel. Any insight on how this mechanism of consciousness interfaces with the angular rotation of these dials to obtain resonance within the holographic field, since the angles of the dial positions and readings of these various instruments all vary?

**JH June 25 2025:** I would need to see this device and study it myself, in order to provide an objective evaluation. I have been positively surprised that your people could develop such a technology. See, understand how human consciousness is a major element in these endeavors. Elena can discuss more about this another time.

With the new political change on Terra, things are quite actively moving forward to slowly disclose the hidden truths to our population with the associated systematic dismantling the criminal deep state elements that will eventually lead toward the full liberation of our planet from these dark elements so that we can move forward in hopes of joining the many star nations of your Federation and start a beautiful new chapter in the history of Terra.

By the way, Christopher was very grateful for your response, and is awaiting the delivery of scientific equipment to his laboratory for further testing on water with the frequency keys you have given.

In great gratitude for all you do Jen Han to help us understand further, your Terran friend Dan

**JH June 25 2025:** Gratitude is from me, dear friends. I wish the development of the current events on your planet will come to a positive conclusion soon enough, for I am eager to meet with you and look at the stars together, from two chairs in your garden.

Jen Han

## Jen Han Eredyon Session – 8-JUL-2025

Dear Jen Han, Grateful as always my dear friend for your help in our understanding of the universe we exist in. A key fundamental understanding of the relationship of the octaves of densities and the fractal core measurement of light that gives certain derivative frequency keys, such as 4096 Hz, that are all built on the same core fractal formula of light is an important understanding of these relationships.

### 1) Reference your answer to my previous question:

Are the 12 densities of this particular universe that are emanating from Source each resonant with one of the octave multiples that relate to the tetrahedral cuboctahedron geometry expanding from...  
1 - 8 - 64 - 512 - 4096 – 32,768 – 262,144 – 2,097,152 – 16,777,216 – 134,217,728 – etc. ?

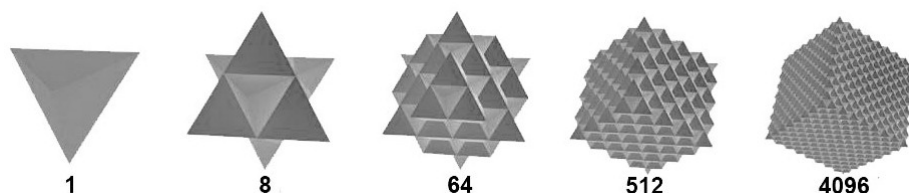

**JH June 25 2025:** That is correct

### If the above is correct, my question is...

Is the 64 tetrahedron grid, the first octave harmonic of scalar growth of the cuboctahedron geometry that represents the first density of the twelve densities in this universe correct?

**JH July 8 2025:** The isotropic 64 tetrahedron grid includes all root geometries as it is a universal geometry: it expands through space, and vibrates through densities and time. In different rates of densities, some geometrical pattern will prevail regarding the structure of the matrix of reality at a particular rate of vibration.

### Dan response to above:

Thank you for helping me gain insight into this tetrahedral density and frequency relationship. I can see where this fundamental isotropic geometry structure would universally expand as in the above visual illustration, where the larger the expansion in the number of tetrahedrons would equate to a higher density rate of vibration, correct?

Referring to the below octave scale of density ratio to tetrahedrons in octave scalar growth would then be correct? For example, the 3<sup>rd</sup> density would resonate with the 4096 tetrahedral structure and also resonate with the frequency of 4096 Hz, just as the 4<sup>th</sup> density I would assume would resonate with the 32,768 tetrahedral structure and therefore it's frequency would resonate at 32,768 Hz, if I am understanding correctly?

### **Octave Scale Example:**

12 densities related to the number of tetrahedron in octave multiples of cuboctahedron geometry

- 1 tetrahedron
- 8 tetrahedrons etc.
- 1 64 (the 1st density octave or beginning scale of creation)
- 2 512
- 3 4096 (3rd density octave?) How does this tetrahedron number relate to the 4096 Hz frequency?
- 4 32,768
- 5 262,144
- 6 2,097,152
- 7 16,777,216
- 8 134,217,728
- 9 1,073,741,824
- 10 8,589,934,592
- 11 68,719,476,736
- 12 549,755,813,888 (The 12th or highest density in this particular universe)
- 13 Source Singularity

Can you give insight into the relationship between the cuboctahedron geometry at the third density level of 4096 tetrahedrons and the frequency of 4096 hertz that represents the fractal core measurement of light in this universe? I don't think these two numbers matching are a coincidence or are they?

**JH July 8 2025:** There are no coincidences in the fundamental geometry of creation, my dear friend. This ratio differs in other universes with different scales of density. A different scale of physicality means a different mathematical ratio. Once you understand the science of the building blocks of the universe, these tetrahedrons, you can create realities, worlds, planets, and stars. Everything. The speed of light depends not only on gravity, but also on density. Light is in perfect resonance with love, water, and quartz. Imagine the lattice of reality in a particular density, like the lattice of a crystal. It has the same resonance capacity, and each node is a potential vortex that can be activated to open to another density or dimension.

### **Dan response to above:**

When you are saying the ratio differs in other universes which have a different scale of densities, for example a different universe having 20 densities instead of 12, would this same cuboctahedron geometry of octave multiples be also stemming from the 1<sup>st</sup> density 64 tetrahedron grid structure, be the same in another universe having 20 densities, the only difference would be adding more octaves up to the 20<sup>th</sup> density level?

From what you are describing as the lattice of reality, it appears the node points in the lattice at any particular density is the vortex gateway to the next density.

## Jen Han Eredyon Session – 11-JUL-2025

### DAN: Questions to JH

1) Density Octave to frequency scale:

12 densities related to the number of tetrahedron in octave multiples of cuboctahedron geometry

1 64 (the 1st density octave or beginning scale of creation)

2 512

3 4096 (3rd density octave?) Assuming this tetrahedron number relates to the 4096 Hz frequency?

4 32,768

5 262,144

6 2,097,152

7 16,777,216

8 134,217,728

9 1,073,741,824

10 8,589,934,592

11 68,719,476,736

12 549,755,813,888 (The 12th or highest density in this particular universe)

13 (Assuming Source doesn't have a frequency and is a singularity?)

**JH JUL 11 2025:** Source is a singularity, it has all fractal frequencies in one. You will understand.

2) If we assume that each density octave resonates with a cuboctahedron tetrahedron array and corresponds to the same number in frequency oscillations cycles. i.e. 3rd octave density = 4096 tetrahedrons = 4096 Hz frequency

Then 4th density would = 32,768 Hz etc up the scale. Then it would be true to say that each individual tetrahedron of the cuboctahedron geometry framework that resonates at each density level is each equal to one frequency oscillation cycle.

**JH JUL 11 2025:** Correct

3) 4096 Hz frequency is effective at removing dissonance in our physical reality because it is at the 3rd density level that retunes harmonically to resonate with creator source which is at a level of perfection. It would be assumed that at higher density levels such as the 4th and 5th densities that 32,768 Hz and 272,144 Hz respectively would be the most effective on those levels?

**JH JUL 11 2025:** Each Density's tetrahedral lattice grid frequency is a fractal number of the singularity. The singularity is not part of the cascade: it is the source of the cascade and the whole at the same time. It is the beginning and the completion.

4) So when we talk about going into higher densities, the higher octave multiple (x8) is of a greater density of more tetrahedrons.

**JH JUL 11 2025:** Correct

5) In other dimensional universes that have more densities, then the same base 1st density starting with 64 tetrahedrons is the same up the octave scale and you simply add the additional octaves to the highest density for the other different universe

**JH JUL 11 2025:** Correct

6) These cuboctahedron structures appear to be the basic fundamental framework of the lattice in each density octave which other more complex multitude of tetrahedral structures are then built upon in the various density levels.

**JH JUL 11 2025:** Correct

7) What is interesting, is that this cuboctahedron structure stemming from the first density consisting of 64 tetrahedrons, forming you could say a rough cube form, as it increases by octaves it forms more and more of a perfect cube form, with the greater number of tetrahedrons giving a smoother surface if you will to form a more perfect cube form at the higher densities.

**JH JUL 11 2025:** Each density's lattice structure's geometry is a proper frequency. Why because frequency is a speed rate. Speed of light, speed of atomic resonance, and so on. Speed of time. I hope you understood by now that light is variable.

**ELENA JUL 15 2025:** Thor Han's colleague High Officer Kiara, in charge of communications on their battle station, got back to me about the quick questions I asked her the other night. I know Kiara well, and she was involved in that moon mission a few years ago when they found the pods. So here is what she said to me yesterday:

**KIARA JUL 15 2025**

Outside your star system, space is not empty. There are a tremendous number of interstellar objects, all moving more or less along and around the galactic plane. The ether is also filled with all sorts of particles, with denser zones alternating with thinner zones in an illogical fashion. Often, objects intercept each other. Fortunately, our planetary systems are well protected by the plasma shields of our stars. A star's gravitational torsion field extends to a limit proportional to its mass-to-velocity ratio. As with a spaceship, the torsion field creates a plasmic shell that prevents interception with other objects. Your comets? They originate from within your star system, specifically from the ice ring that you call the Oort cloud. Interstellar objects need to pass through the plasma shield. This is an exception, as passive objects are usually diverted from the plasma shield by galactic gravitational currents. Though rare, it does happen that a natural object passes through the shield.

Unnatural interstellar objects, such as spaceships, are most likely to pass through because they have their own torsion field. You can have spaceships that look like rocks, either for camouflage or because it is a particular way of doing things for some cultures. The Zenate are masters at it. The Intergalactic Confederation does that a lot, too. These objects may be abandoned or remote probes sent by a mothership somewhere out there. They may also carry a crew or be inhabited by a consciousness. Yes, living beings.

On another note, you asked me about the disturbing transmissions and data received by the Voyager 1 and Voyager 2 probes. I can answer that, but you already know the answer. These transmissions are not directly emitted by our ships or the Intergalactic Confederation's armada. Rather, they are part of a mesh of communication signals. As I told you, space isn't empty. Space, also called the ether, is a medium that carries signals when they pulse through it. Imagine this: A signal carrying encoded information pulses through the ether with an encoded destination. The ether becomes agitated and generates a quantum carrier wave. Although I am not talking about a wave in the traditional sense, this wave propels the signal intact to its destination without weakening it. The ether has a quantum property that goes beyond your science because it distorts space and time. Time is not linear as they think on Earth. Neither is space. Space is a quantum medium. Linearity is gravity. Mass cancellation equals gravity cancellation and time cancellation.

In your star system, linear time exists due to the gravitational fields of the star and planets. Time becomes linear in proportion to the star's velocity and mass. This is why you have heard us say that time is experienced at different speeds depending on which star system you are from. The linear times on Mars and Earth are based on the same ratio, which is determined by the star's gravitational force. I'm not talking about a planet's orbital or spinning times, understood? I am talking about the time base. The two Earth probes also heard the "Song of Creator." Her breath. They also sensed her presence and the field of her consciousness. We can hear it, or our instruments can record it. We call it "the song." Each planet has a song. Imagine the great beyond with an infinity of symphonies that are, in truth, the songs of gravitational fields. There is no void in space. Oh, no, there isn't. It is quite the opposite. The only real void is the great quantum void between the universes.

Outside the plasma shield of your star system, the frequency abruptly jumps. This is because of where your system is at that moment in time and space along the galactic ecliptic of Nataru. Your probes recorded that as well. Isn't it beautiful? Science is beautiful. The laws of Creation are the ultimate beauty.

## Jen Han Eredyon Session – AUG-18-2025

Hello my dear friend Jen Han,

Over these years of our exchanges for the science transfer program to Terra, we've been able to have a beginning basic level of understanding of your science and are always honored and in great appreciation of all that you have shared with us. I wish to check with you if the following understandings of what you have shared recently are correctly interpreted or not.

### 1) An understanding check:

Within the multiverse of infinite dimensional bubble-like spheres of these universes, each filled with ether and existing within the void. All these overlapping spheres are structured in a pattern stemming from the pattern of creation known as the flower of life. Each dimensional sphere varies and is uniquely different, because they exist within the void, which is outside of linear time and space, hence the variation of various lifeforms within each sphere. This is also why we see in nature approximations of the Fibonacci sequence ratio of growth patterns (1, 2, 3, 5, 8, 13, 21, 34, 55, 89, 144 etc.) but are rarely exactly this precise 1.618 ratio. The Source singularity within each bubble-like sphere emanates within the center of the sphere radiating outward fractals of consciousness from a level of absolute perfection and the pure frequency of love, which emanates like gravity waves through the octaves of densities that are geometrically superimposed into an ordered state of geometrical resonance.

Each living creatures heart beat is entangled reciprocally to this one singularity of Source, which is in turn linked to their planet, and then to their star, to their galactic center, to their universes center, and then to the Source singularity and back, all united as one unified expression of creative Source. Each dimensional universe or sphere can have different levels of density octaves, but all have a foundation based on their first density octave geometry being the isotropic 64 tetrahedron grid, in which the cuboctahedron geometry scalar octave growth to the 3<sup>rd</sup> density increases to a 4096 tetrahedral structure, whereas each tetrahedron represents one frequency oscillation cycle for the number of tetrahedrons at each density level, therefore the 4096 tetrahedral structure resonates at a frequency of 4096 Hertz in the 3<sup>rd</sup> density. This scalar octave growth multiplies at each density level by a factor of 8 up to the particular universe's highest density level before reaching it's Source singularity of which all the octave densities emanate from for it's universe's dimensional sphere.

Therefore, the isotropic 64 tetrahedron grid being universal geometry as the first density octave in all universes, would mean the 4096 Hertz frequency would be resonant in the 3<sup>rd</sup> density of any universe.

Is the above an accurate description?

JH (Aug 20 2025): This is all correct. You can hereafter estimate that the fractal frequency oscillation of Creator Source is based on this ratio but as an infinite value. Remember when I told you that creation tends towards perfection? Perfection is one with infinity.

## 2) The function of the 4096 Hz frequency coupling to the universal frequencies of Source

It is understood that when ether quartz or water, which are both interdimensional bridges, are resonated with the frequency of 4096 Hz, their structures come into perfect geometrical state of resonance with the Source singularity, which is at a level of perfection, which when attuned to, does not allow dissonant patterns to exist within the quartz or water structures. I am assuming that because we as beings are experiencing our reality primarily in the 3<sup>rd</sup> density, is why the 4096 Hz frequency has been chosen, as it resonates matter most effectively at this octave level? Due to the multi-density / multi-dimensional resonance qualities of both quartz and water, when excited by the 4096 Hz frequency is there a form of harmonic coupling through the higher octaves (4096 > 32,768 > 262,144 etc.) increasing in frequency closer to the Source singularity which is then reflected back down across the cascade of octave harmonics of the geometrical spectrum back into the 3<sup>rd</sup> density level, carrying with it this reflection from the highest level and thereby re-tuning the quartz or water structure to this higher level state of resonance closer to perfection, due to the quartz and water's ability to resonate across the harmonic spectrum of octaves? Or more precisely, how does this re-tuning work?

JH (Aug 20 2025): Fractal cascade harmonics work both ways. However, when they are in synchronism with the Source's infinite frequency, they realign the entire cascade to achieve perfect resonance. This means that the impulse is in resonance and can exist throughout the entire cascade simultaneously.

## 3) 4096 Hz sonic versus electromagnetic clearing of water

I know previously you suggested to use the sonic method to clear water. Since we were able to clear quartz placing it inside of a cylinder wrapped in copper wire wound star-wise with a 4096 Hz sine wave signal applied, I was wondering if a star-wise wrapping of copper wire around a electromagnetically transparent water pipe in which water flows through would yield any clearing results of the water, since it worked well with quartz? Is there another factor regarding sonic versus electromagnetic?

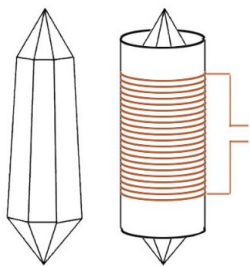

JH (Aug 20 2025): It purifies water. Sonic technology is more efficient than electromagnetic fields, which can never be an accurate source. Imagine your operation is located on a planet with its own electromagnetic pulse, in an environment that is subject to electromagnetic bombardment. Results with a sonic pulse are more accurate. As you know, quartz is an immeasurably more powerful tool than water, which has other qualities. Despite being in fractal lattice resonance with quartz, water has different applications to quartz and reacts to impulses at a different scale.

#### **4) Resonating 4096 Hz sonic waves in a glass of water before drinking**

Whenever I drink a small glass of water, I always place a 4096 Hz audio resonator right above the water for about 5 seconds and visualize it with my consciousness of it coming into resonance with the Creator Source singularity. Do you think this short time duration exposure is effective enough in affecting the quality of the water?

JH (Aug 20 2025): It is enough.

#### **5) Is there any relationship between the frequency octaves and the fractal core pattern formula?**

Since quartz, water, light and love are derivatives from this fundamental fractal core pattern formula, is there a relationship to the below frequencies of the 12 densities of our universe related to the number of tetrahedron in octave multiples of cuboctahedron geometry?

- 1 64 (the 1st density octave or beginning scale of creation)
- 2 512
- 3 4096
- 4 32,768
- 5 262,144
- 6 2,097,152
- 7 16,777,216
- 8 134,217,728
- 9 1,073,741,824
- 10 8,589,934,592
- 11 68,719,476,736
- 12 549,755,813,888 (The 12th or highest density in this particular universe)

I understand the speed of light traveling through the ether is different at each density level and is different in different universes, and that it also varies according to the gravitational field which also affects the flow of time.

JH (Aug 20 2025): time and the appreciation of space are experienced differently by avatar-incarnated consciousness, in each density. To travel in time you can use the density bridge, way and back. You will come back at a time location much farther into the future if you jump through a higher density bridge. this type of time travel is called “bridging time frequency”. There are different ways of travelling through time. Changing the speed of light is also bridging time.

You see, we use technology to transport vehicles and their occupants through time. However, we can also project our consciousness through higher states of awareness — that is, higher densities — to see into the future. We, Ahil, can predict the future with an accuracy of more or less five days. Beyond that threshold, we need technology to see into the future.

JH (Aug 20 2025): Yes, the cascade is right.

## 6) Regarding time

I understand that time becomes linear in our experience in proportion to our star's unique gravitational field, velocity and mass which determines the degree of the dilation of time to give us this moment to moment linear experience of the passage of time. This I understand is different on different star systems that create their own unique time base for the passage of time, such as on your planet Erra.

JH (Aug 20 2025): Yes, correct.

When completely outside of any gravitational field influence, how is time experienced?

JH (Aug 20 2025): When non-incarnated into biological matter or any plasmic polarization, time is experienced as a whole, as the Time Field.

I know your ships create your own gravity systems which create a linear time experience within your ship.

JH (Aug 20 2025): Correct, we also generate a chosen density rate.

When our Terran envelop expires and our soul leaves our physical existence, does the soul experience a state of non-linear time and space?

JH (Aug 20 2025): Yes.

It appears, that the holographic field has a time vector which is tune-able to see the past or future. When one uses technology to view future events in time, are these future events based on a probable future that takes into account what is happening at the present moment which is forming the trajectory of that future? In other words, it is not an immutable future time line, and is one that can be circumvented and altered to change the future?

JH (Aug 20 2025): Pertinent. There are two different aspects of time vision: the fixed outcome and the fluctuating path. The fixed outcome is the configuration of the lattice of time that is based on the spiral of evolution. The fluctuating path consists in the infinite ways to get there.

Our Terran Solar Warden program has been using a personnel recruit program to age and time regress personnel for a 20 year tour of duty. Regarding the time regression aspect. Apparently there is this ability to relocate to a point and place in time. Are points in time operating at a different frequency that they are able to physically age regress a person so that they return to their point in time 20 years prior at their place of enlistment? What are the principles of how this time regression occurs?

JH (Aug 20 2025): This uses holographic time-bridging. The lattice of physical reality is holographic. It can be easily manipulated when you have the right technology. You may recall that this is used in biological repair technologies when a resonant template is merged with an altered one. These programs perform age regression using a similar method, but with a twist. Most of the time, the holographic

template of the adult body of the soldier has been artificially enhanced or even cloned many times, resulting in a loss of resonance with the original avatar. This means that it cannot be regressed using a linear method. Instead, quantum time bridging is needed rather than linear time regression. Using the same genetic template — DNA is a holographic signal key — we transpose the adult consciousness onto an earlier version at a precise location in time that we can easily identify, as the moment of physical abduction is recorded in the being's time field. Then we transfer the consciousness back. By quantum teleportation, if you will. Please note that this is not a physical regression in time, but rather a transfer of consciousness back in time. They then dispose of the empty body.

### 7) Resonance and dissonance in pattern formations within water

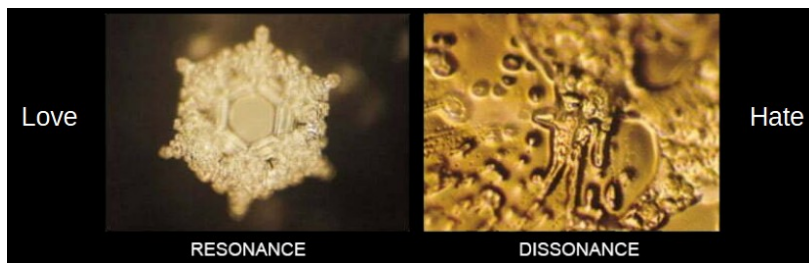

Experiments have been done with water crystallization exposed to conscious thoughts of both love and hate. Revealing that the love frequency forms symmetrical intricate hexagonal unique patterns within the tetrahedral molecular structure of the water, whereas the hate frequency is unable to take such form. This appears to verify what you have previously said that “Dissonance cannot attune with an ordered state of geometrical resonance”, with water representing an inter-dimensional bridge resonant across the geometrical octaves of densities which represents this ordered state of geometrical resonance.

Note: Jen Han did not respond to this statement

### 8) Red mercury ore crystals to enhance Phryll generator output.

Our scientist Christopher is acquiring some red mercury ore crystals on Terra called “Cinnabar” in order to increase the gravity pulse on the quartz when the torsion field is activated to substitute for the red Khor crystals which are unobtainable on our planet.

The only reference we have as to how to configure the red mercury ore crystals around the central core quartz crystal, is this rough image from Elena’s memory of how the crystals are positioned around at the base.

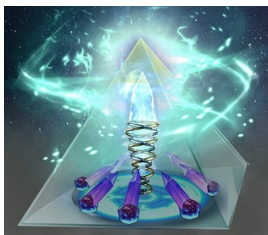

Should we be looking for single crystal points, or does the red crystals need to be cut in alignment with their lattice to form a projecting point?

JH (Aug 20 2025): Khor only needs to be in its original crystalline aspect to increase the gravity pulse it receives. You can cut it for directional impulse purpose when in Phryll generation machinery. Watch out for the power it can unlock.

Are there a total of 6 red crystals, each crystal placed facing one of the 6 facets of the quartz central crystal?

JH (Aug 20 2025): This depends on the technology and the application. For general use, it is 3, 6 or 12; in a pyramidal setting, it is 4, 8 or 16. For a small Phryll generator, such as the ones you are experimenting with, six is enough. If used with a harvester, then 8.

Do these all point at the vortex eye of the crystal?

JH (Aug 20 2025): yes.

Are these red crystals needing to be excited in any manner to enhance their functionality?

JH (Aug 20 2025): Yes, with gravity pulse.

Two questions from Christopher:

### **9) Is the form of matter composed of standing wave-forms?**

Is everything we know about molecules, atoms, and physical matter simply standing waves in the fractal tetrahedral structure of spacetime?

JH (Aug 20 2025): Nothing stands, everything created fluctuates in space and in time, and on the curve of evolution of consciousness. These three constants always work together. Time, space, consciousness. Yes you can call the pulse of existence “standing waves”: pulsating waves encapsuled into fractal geometry.

### **10) Space-time resonance with quartz lattice structure and opening of the eye**

Am I correct in my understanding that the underlying space-time itself a fractal tetrahedral structure?

JH (Aug 20 2025): you are correct. It varies regarding densities of existence.

My understanding is that Quartz crystal has a perfect lattice match to the tetrahedral structure.

JH (Aug 20 2025): Yes. Quartz is a transponder.

It would follow that when quartz resonates at a space-time resonance frequency, energy transfers from the quartz tetrahedral matrix to the space-time tetrahedral matrix.

JH (Aug 20 2025): yes.

Is the effect of the resonate frequency energy transfer opening the quartz crystal eye singularity?

JH (Aug 20 2025): All you need is a gravity pulse to tear a hole in the lattice of spacetime-consciousness. The signal you will broadcast through it is entirely up to your decision.